

52 Beacon St

**52 Beacon St
Boston, MA 02108**

**BHAC REVIEW SET
11/29/2016**



222 Third Street, Suite 3212
Cambridge, MA 02142

tel: 617 621-1455
fax 617 621-1477

www.LDa-Architects.com

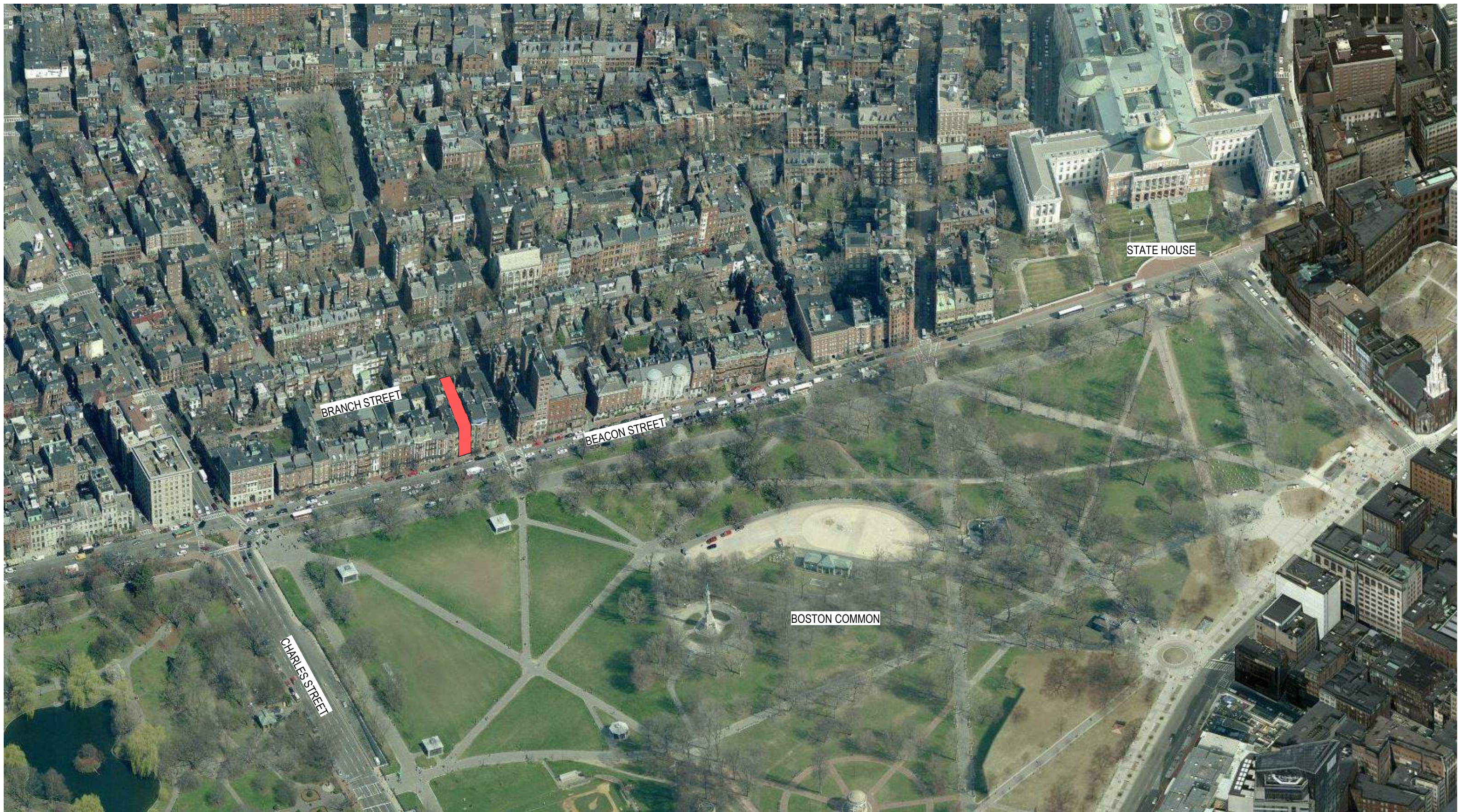

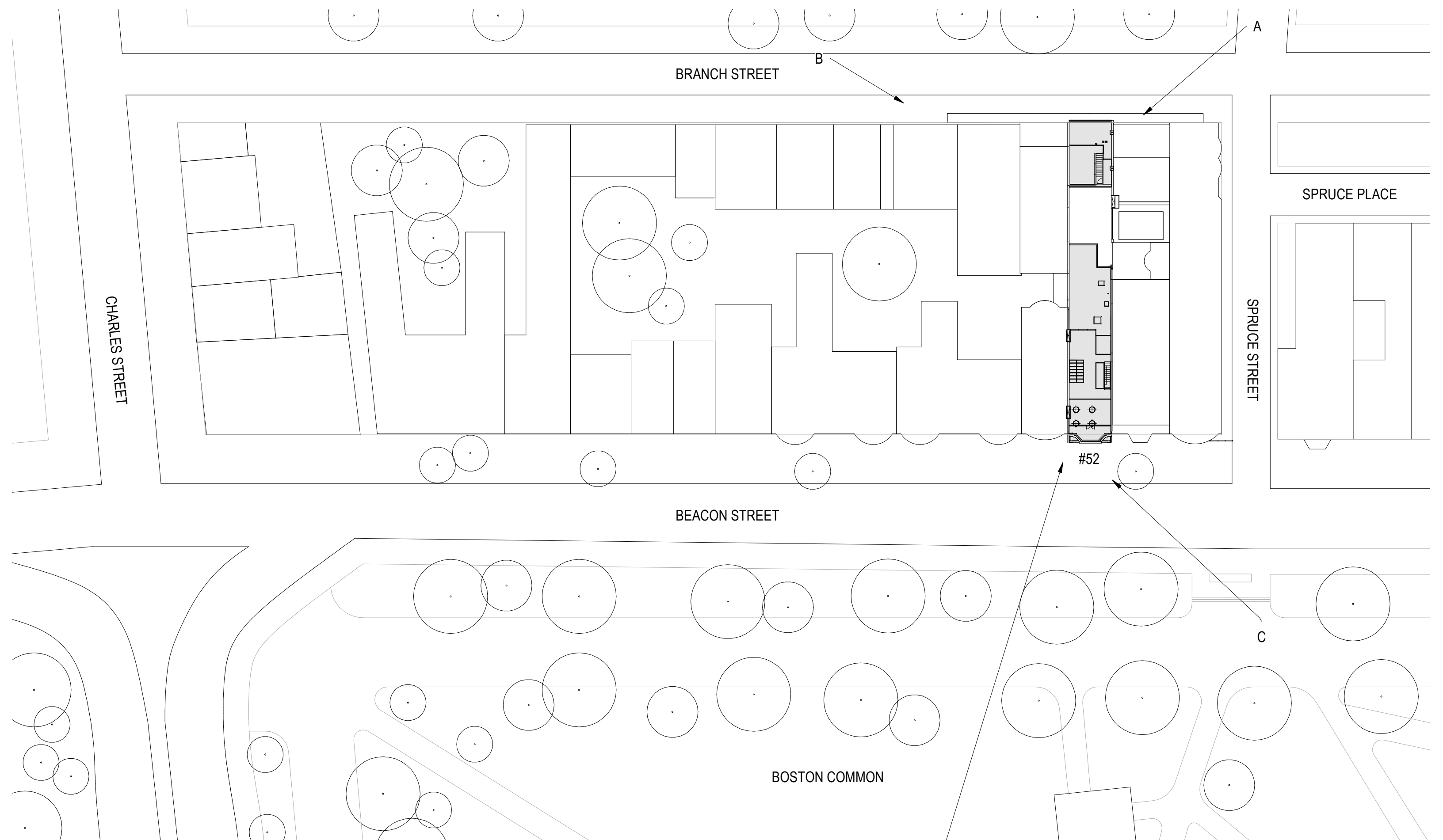



BEACON STREET FACADE



BRANCH STREET FACADE

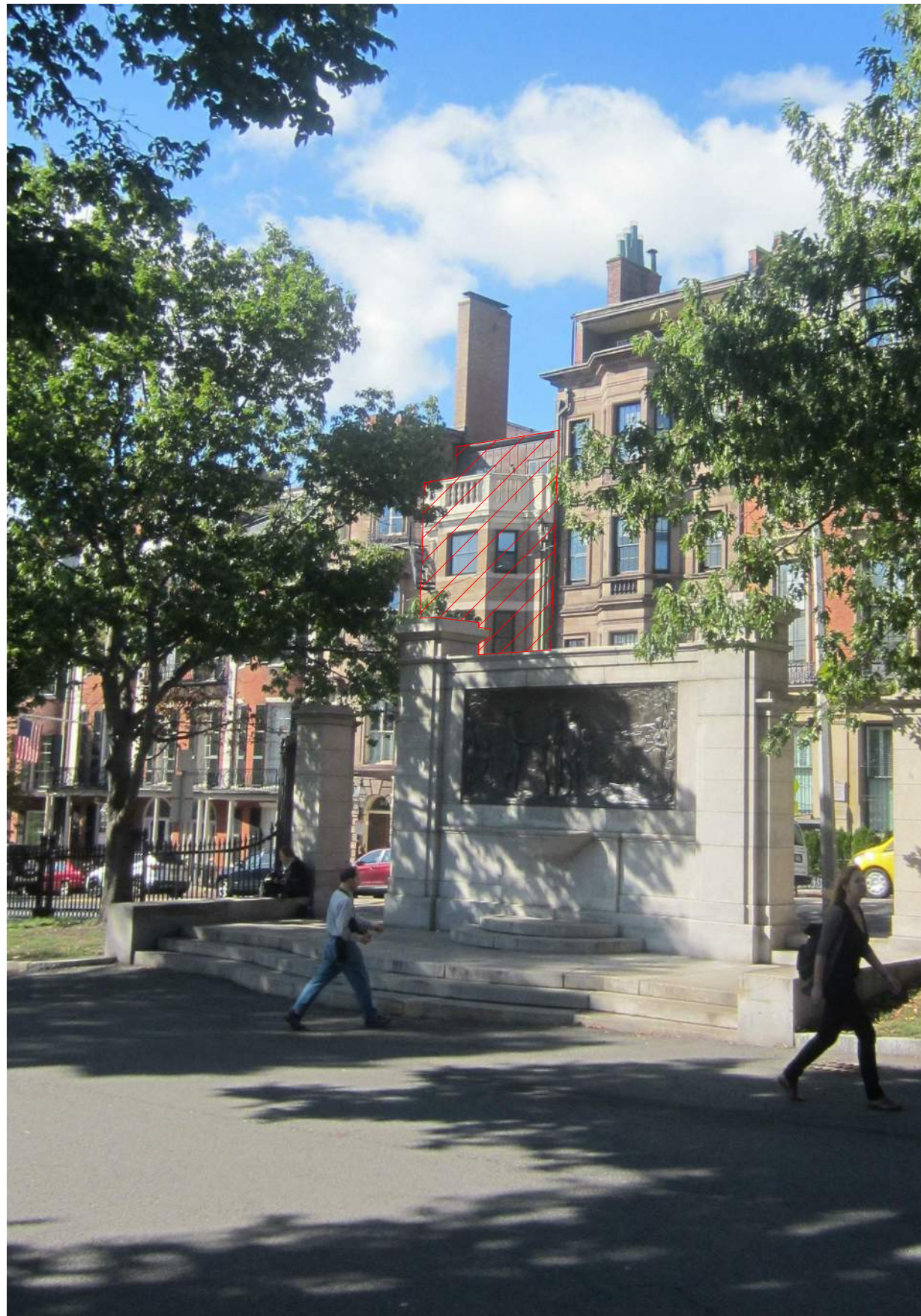

SITE PHOTO C



SITE PHOTO D



SITE PHOTO A



SITE PHOTO B

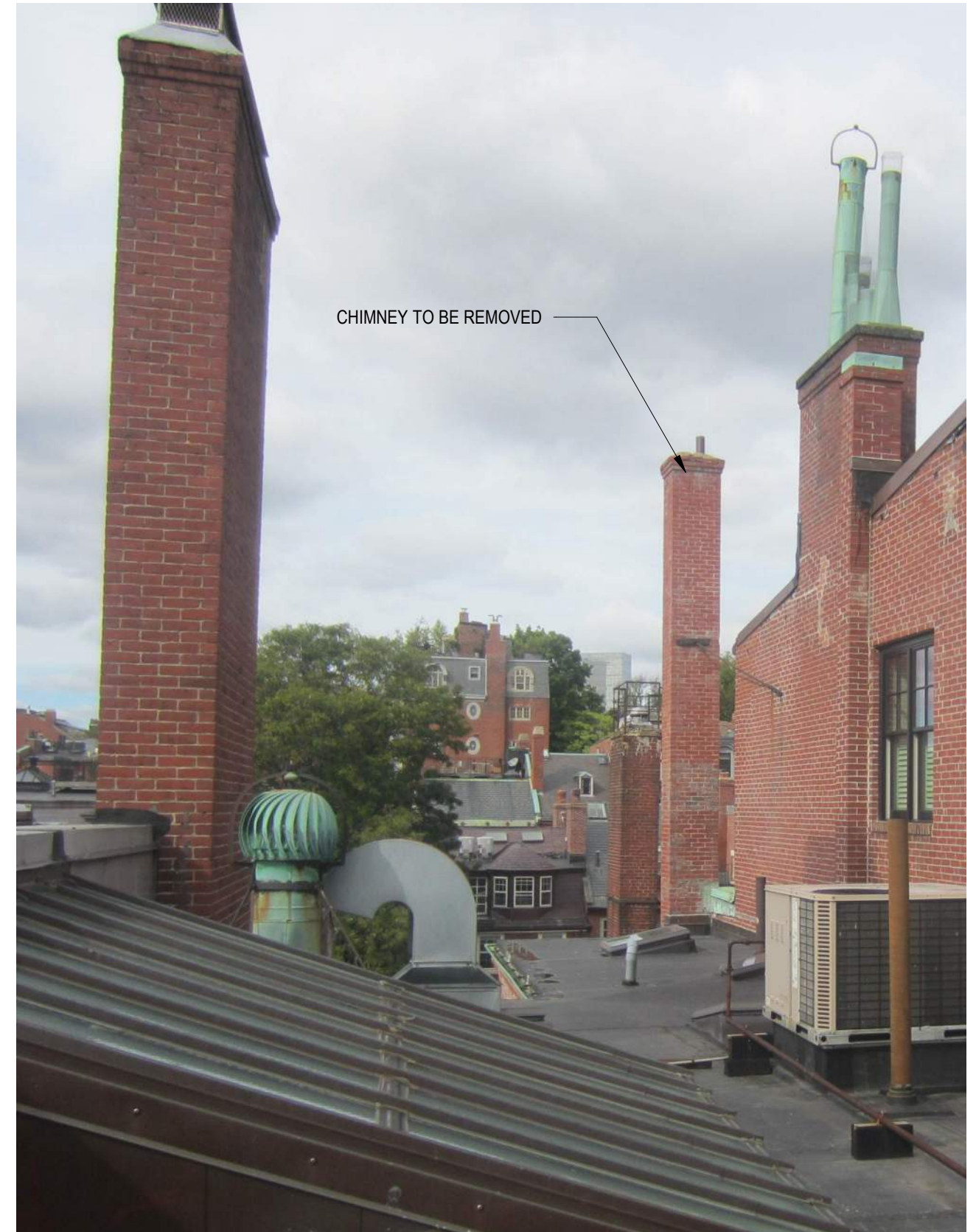
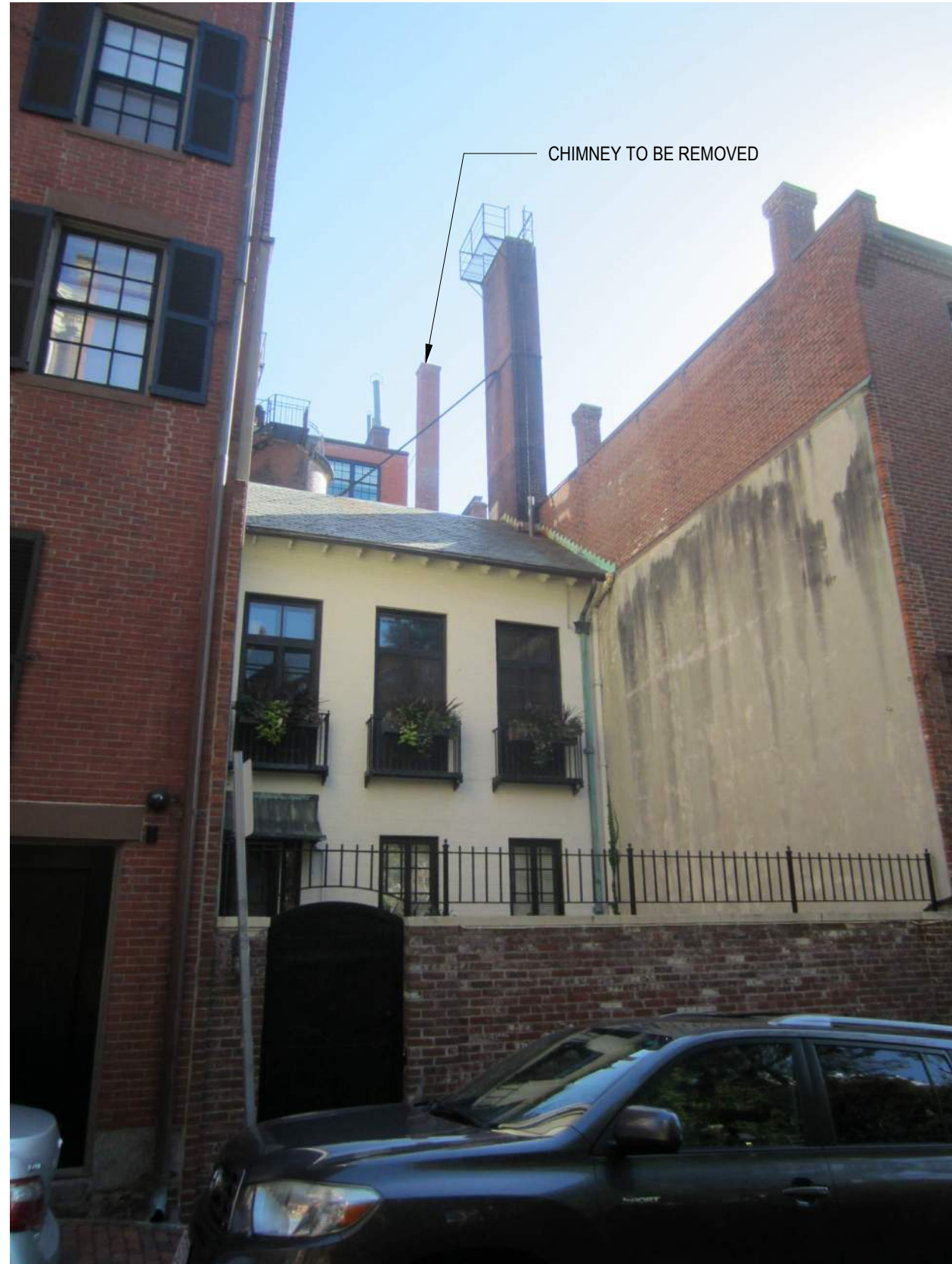

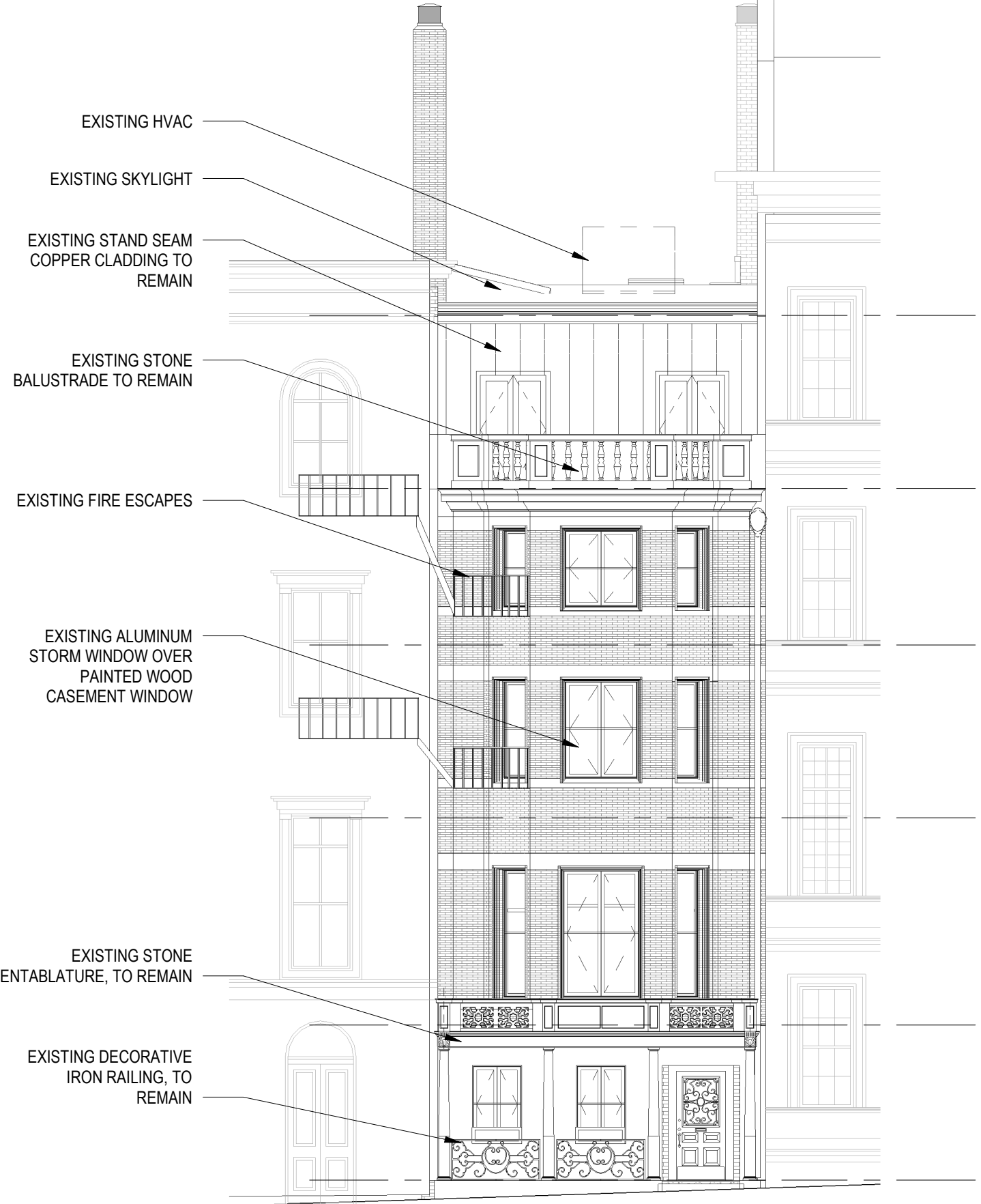

- EXISTING HVAC
- EXISTING SKYLIGHT
- EXISTING STAND SEAM COPPER CLADDING TO REMAIN
- EXISTING STONE BALUSTRADE TO REMAIN
- EXISTING FIRE ESCAPES
- EXISTING ALUMINUM STORM WINDOW OVER PAINTED WOOD CASEMENT WINDOW
- EXISTING STONE ENTABLATURE, TO REMAIN
- EXISTING DECORATIVE IRON RAILING, TO REMAIN

1 1-EAST EXISTING
SCALE: 1/8" = 1'-0"

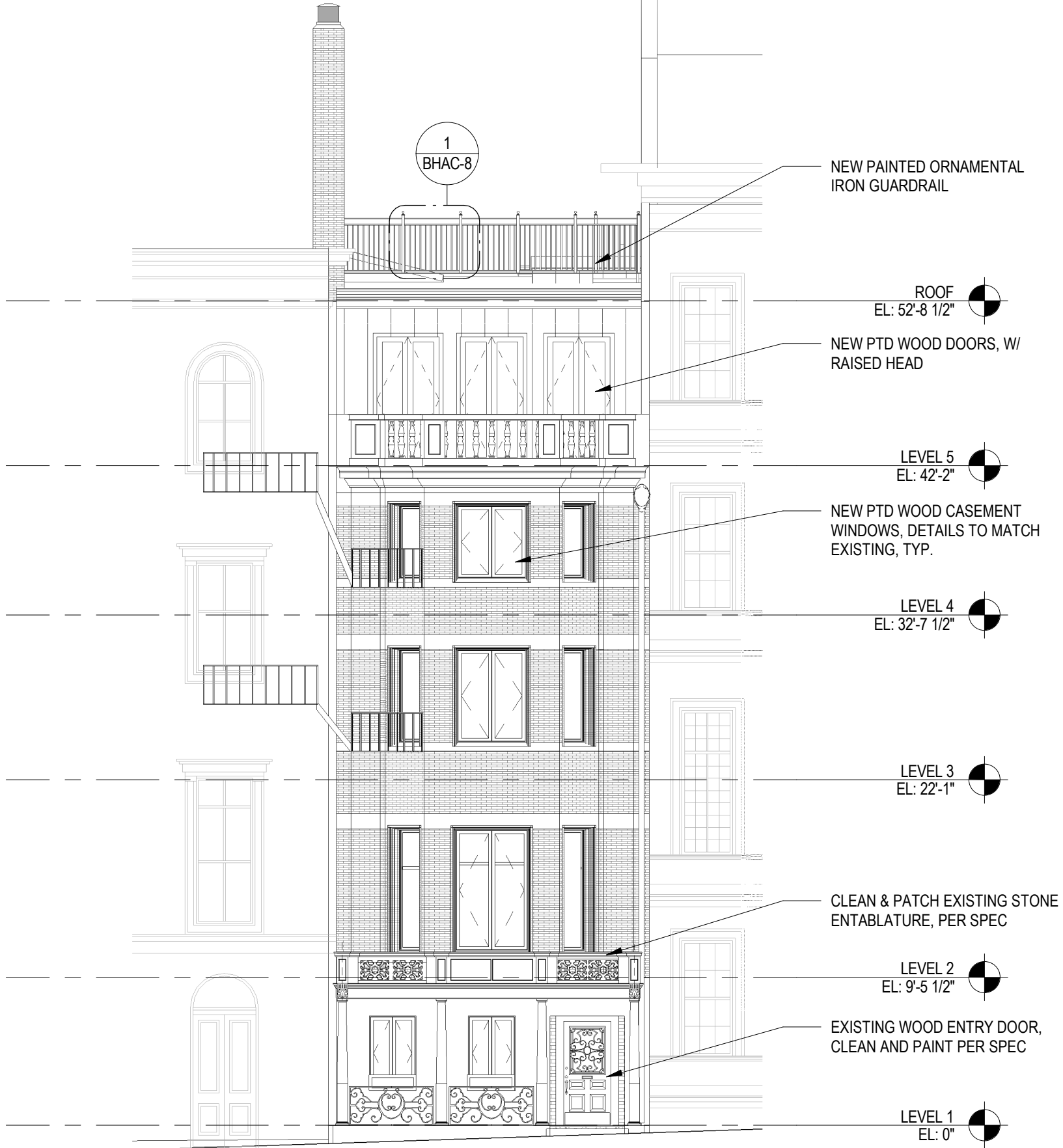

1
BHAC-8

- NEW PAINTED ORNAMENTAL IRON GUARDRAIL
- ROOF
EL: 52'-8 1/2"
- NEW PTD WOOD DOORS, W/ RAISED HEAD
- LEVEL 5
EL: 42'-2"
- NEW PTD WOOD CASEMENT WINDOWS, DETAILS TO MATCH EXISTING, TYP.
- LEVEL 4
EL: 32'-7 1/2"
- LEVEL 3
EL: 22'-1"
- CLEAN & PATCH EXISTING STONE ENTABLATURE, PER SPEC
- LEVEL 2
EL: 9'-5 1/2"
- EXISTING WOOD ENTRY DOOR, CLEAN AND PAINT PER SPEC
- LEVEL 1
EL: 0"

2 1-EAST PROPOSED
SCALE: 1/8" = 1'-0"

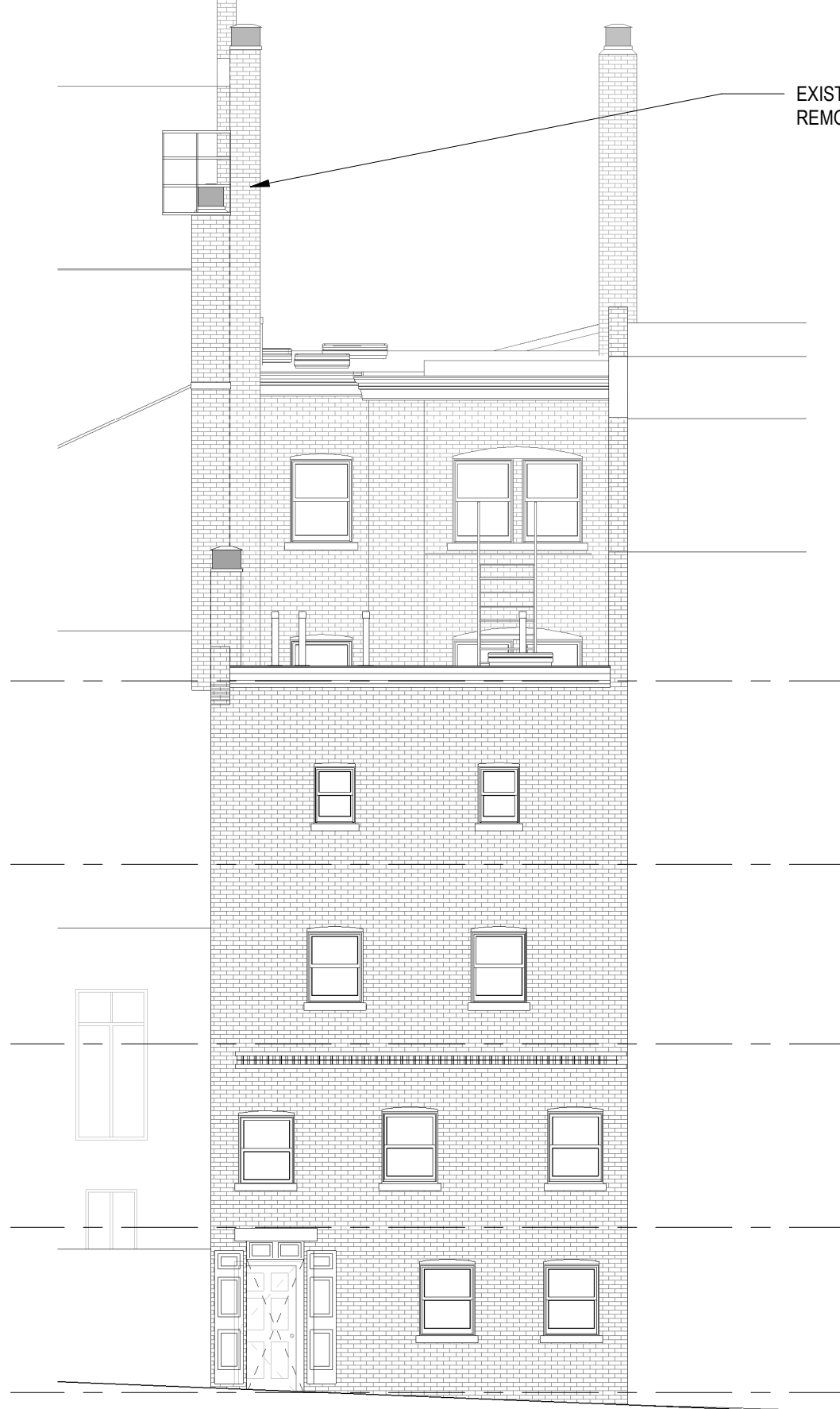

1 3-WEST EXISTING
SCALE: 1/8" = 1'-0"

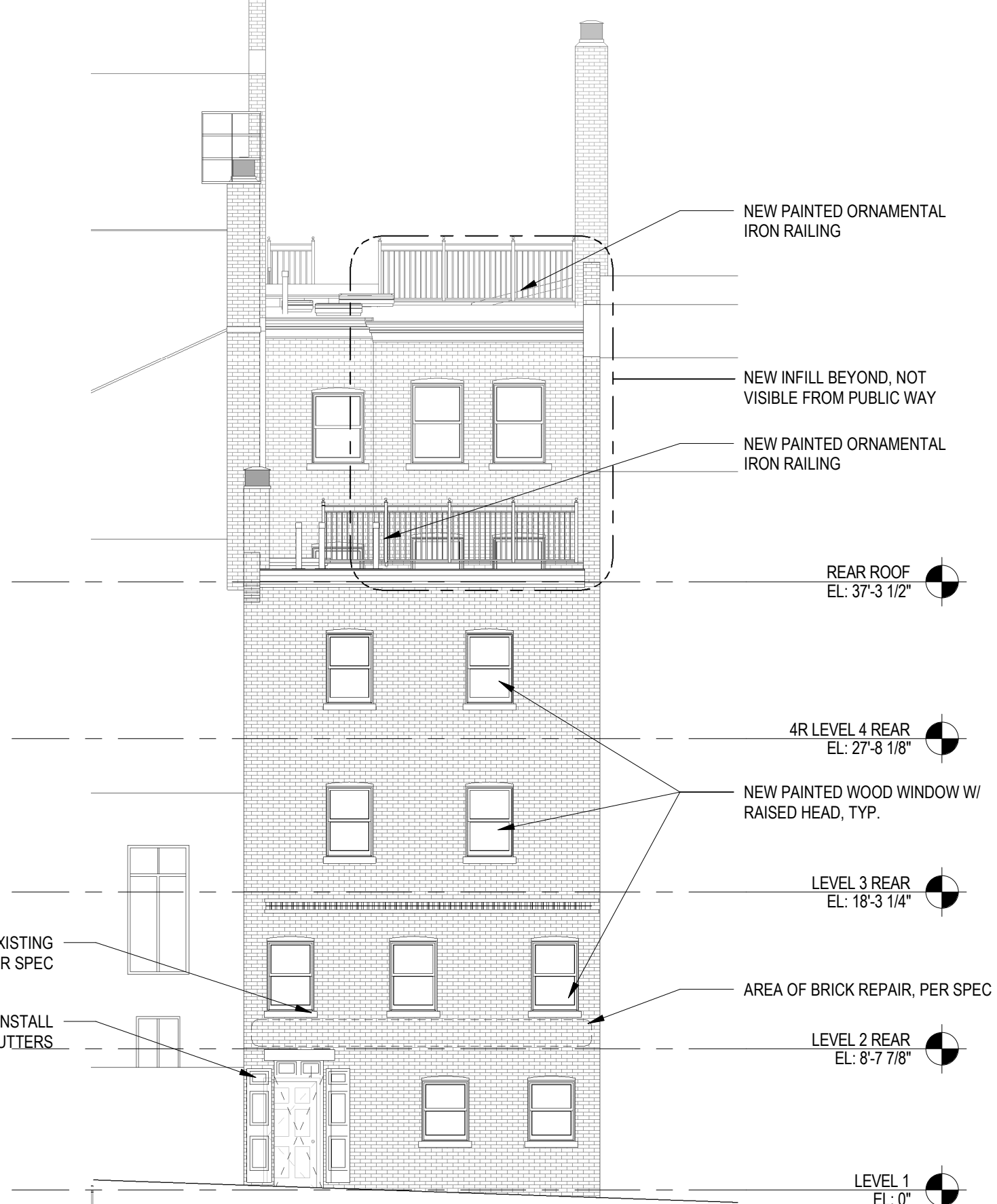

2 3-WEST PROPOSED
SCALE: 1/8" = 1'-0"

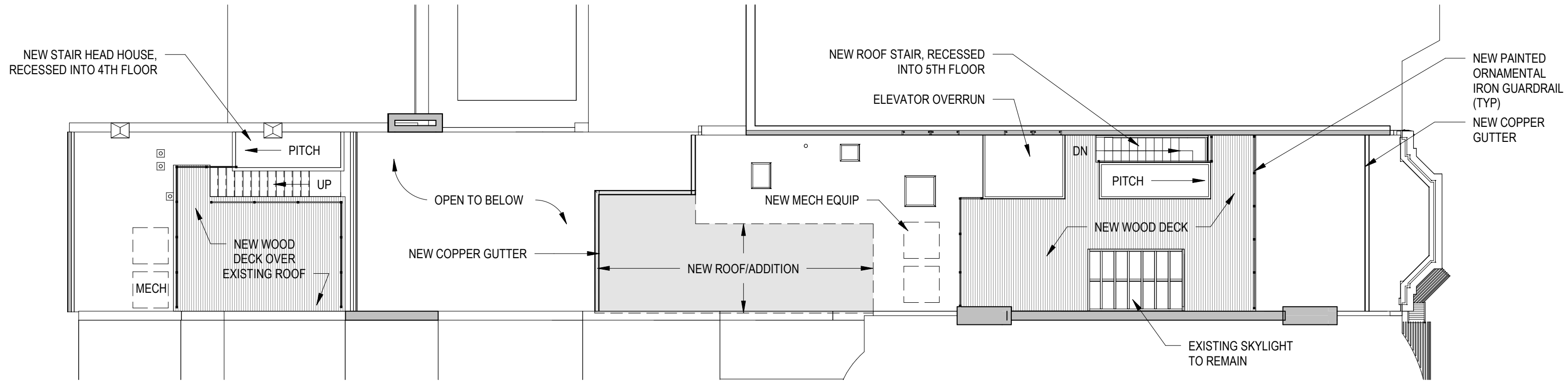

1 PROPOSED ROOF
SCALE: 3/32" = 1'-0"

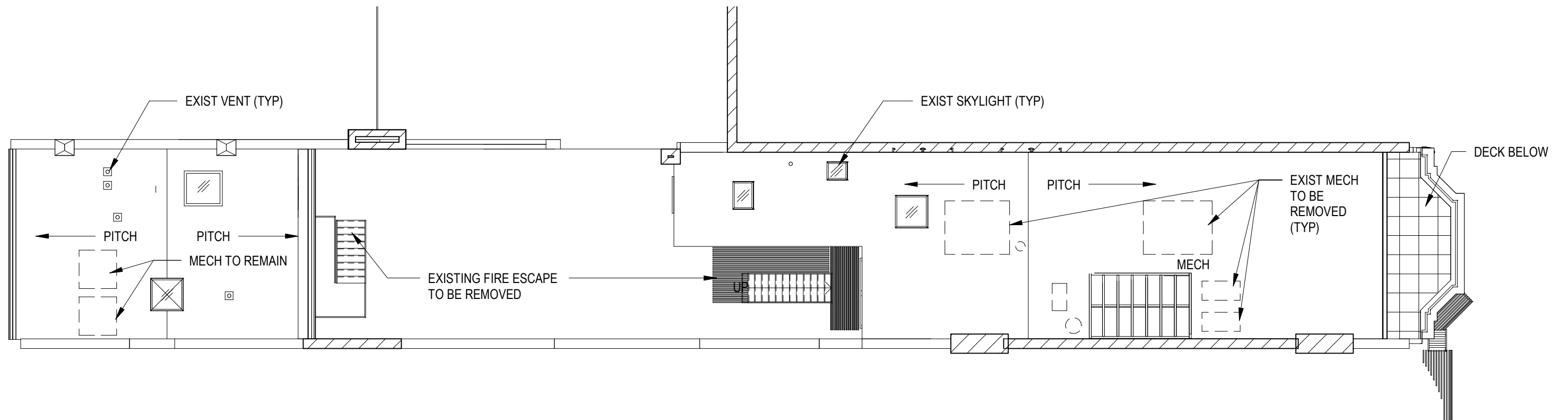

2 EXISTING ROOF
SCALE: 3/32" = 1'-0"

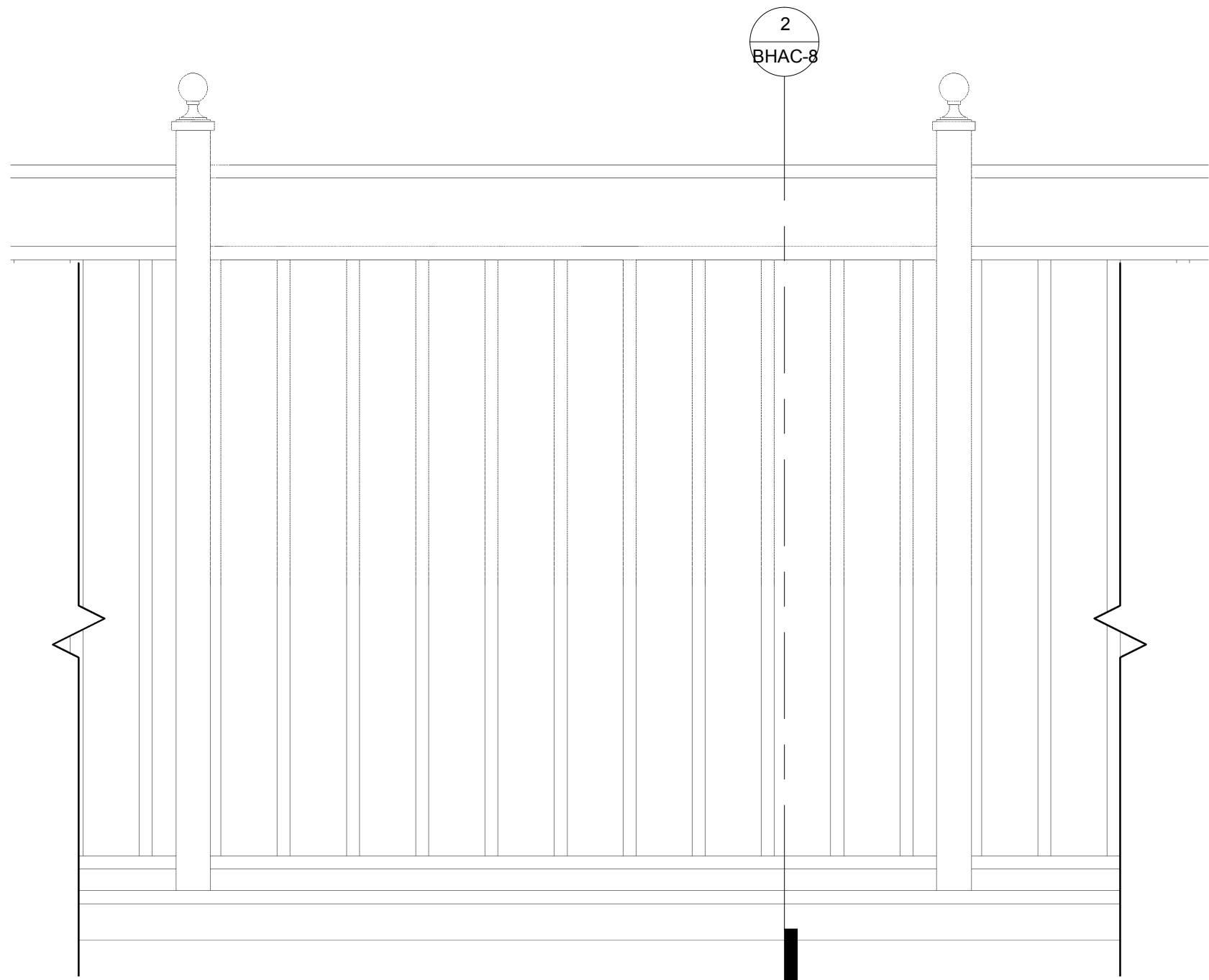

1 ROOF RAILING
SCALE: 1 1/2" = 1'-0"

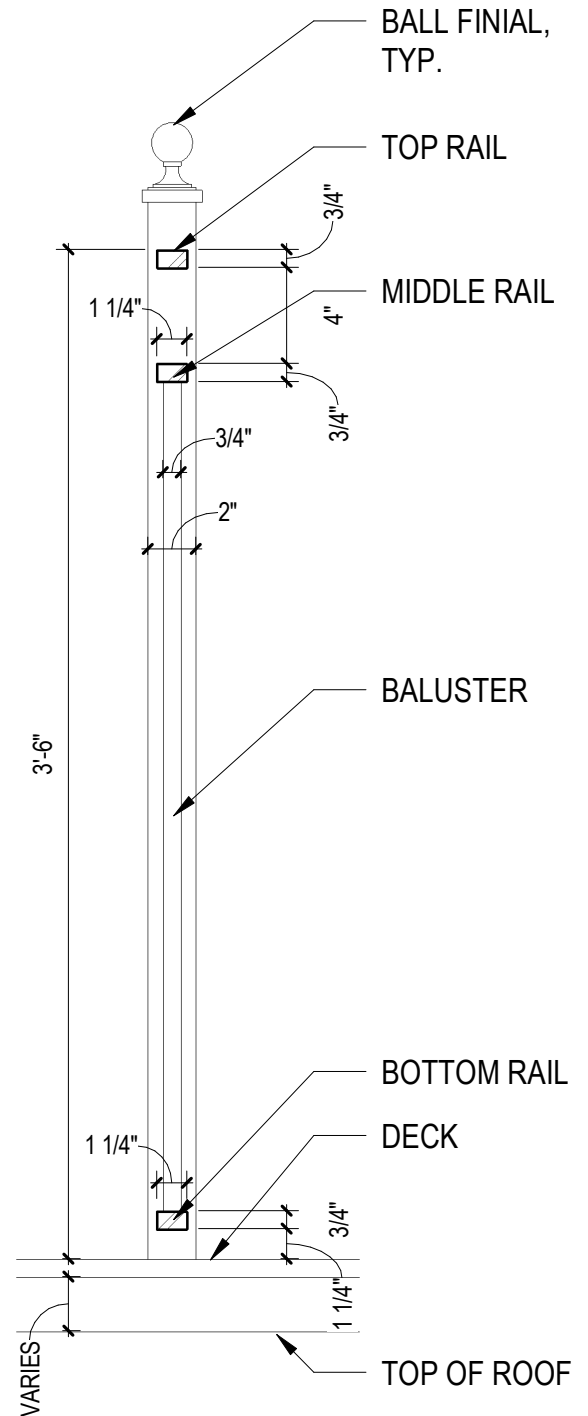

2 RAILING DETAIL
SCALE: 1 1/2" = 1'-0"

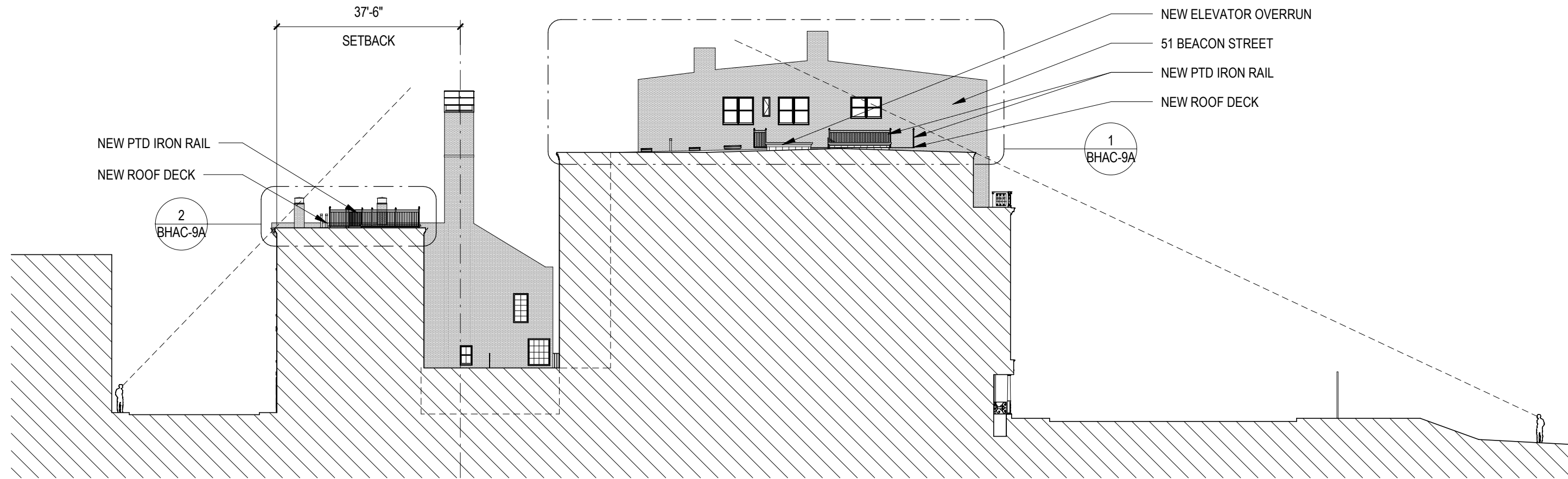

1 SITE SECTION PROPOSED
 SCALE: 3/64" = 1'-0"

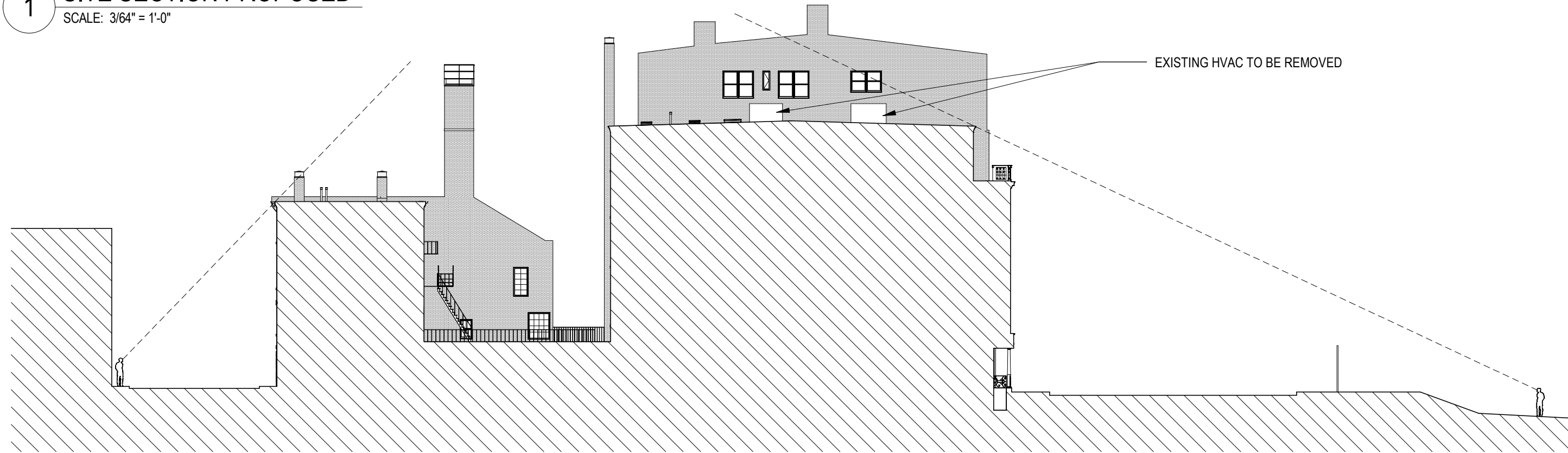

2 SITE SECTION EXISTING
 SCALE: 3/64" = 1'-0"

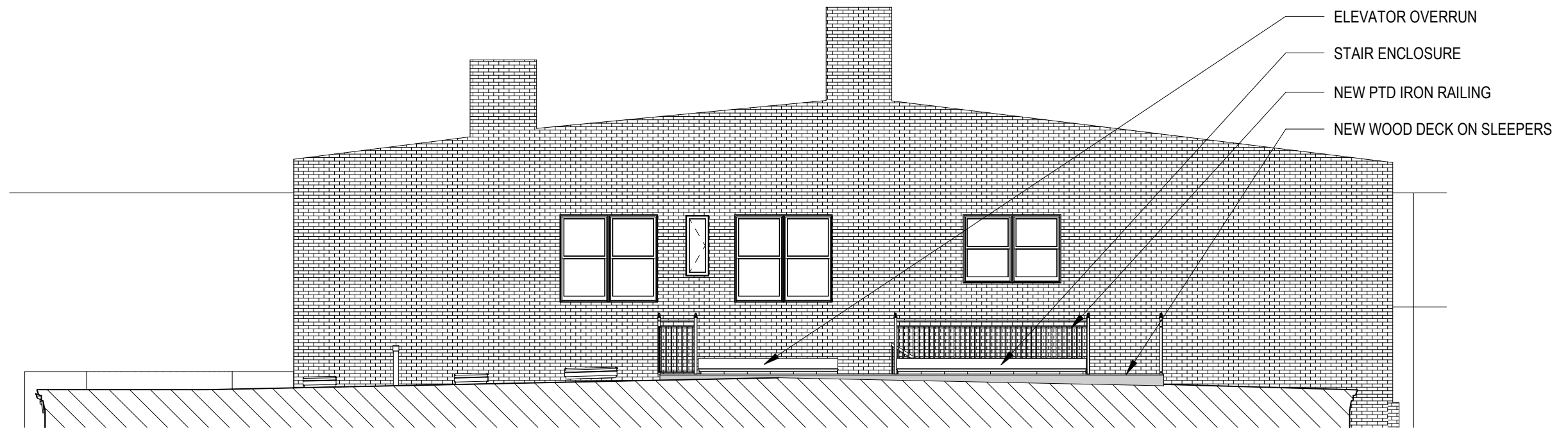

1 BEACON STREET ROOF SECTION LOOKING EAST
SCALE: 1/8" = 1'-0"

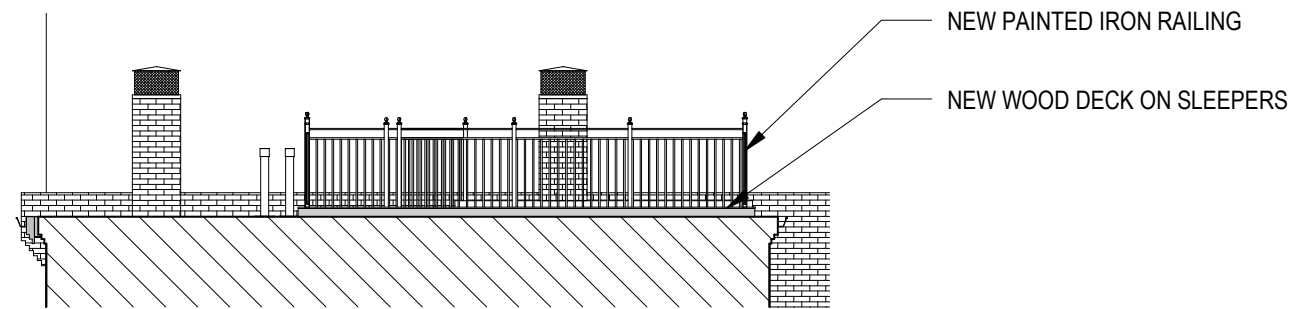

2 BRANCH STREET ROOF SECTION LOOKING EAST
SCALE: 1/8" = 1'-0"

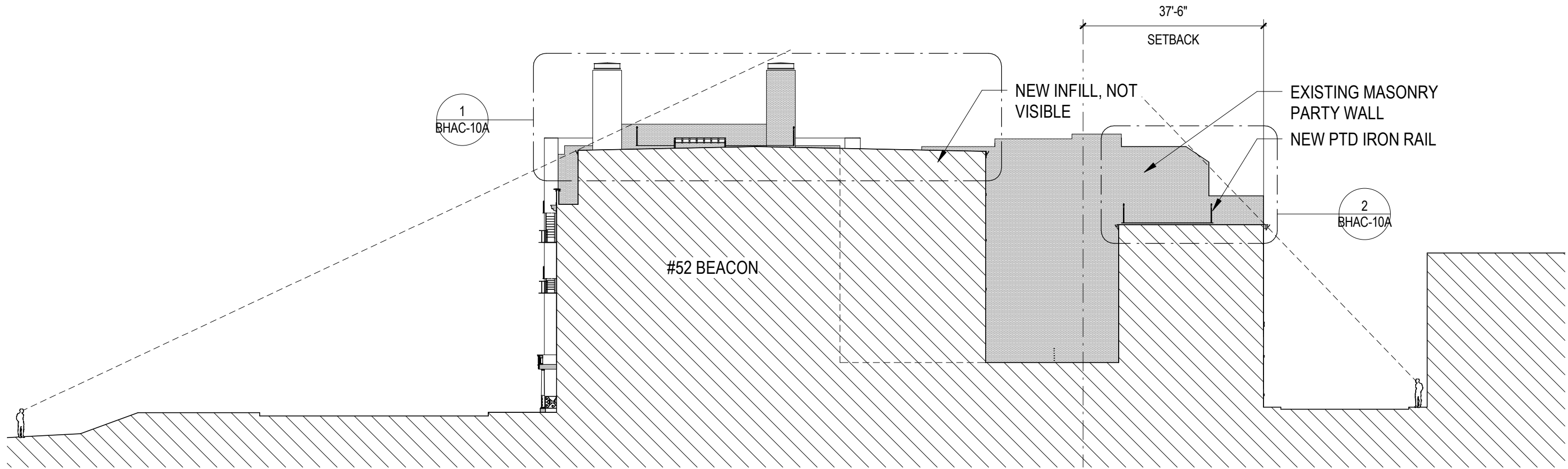

1 SITE SECTION 2 PROPOSED
 SCALE: 3/64" = 1'-0"

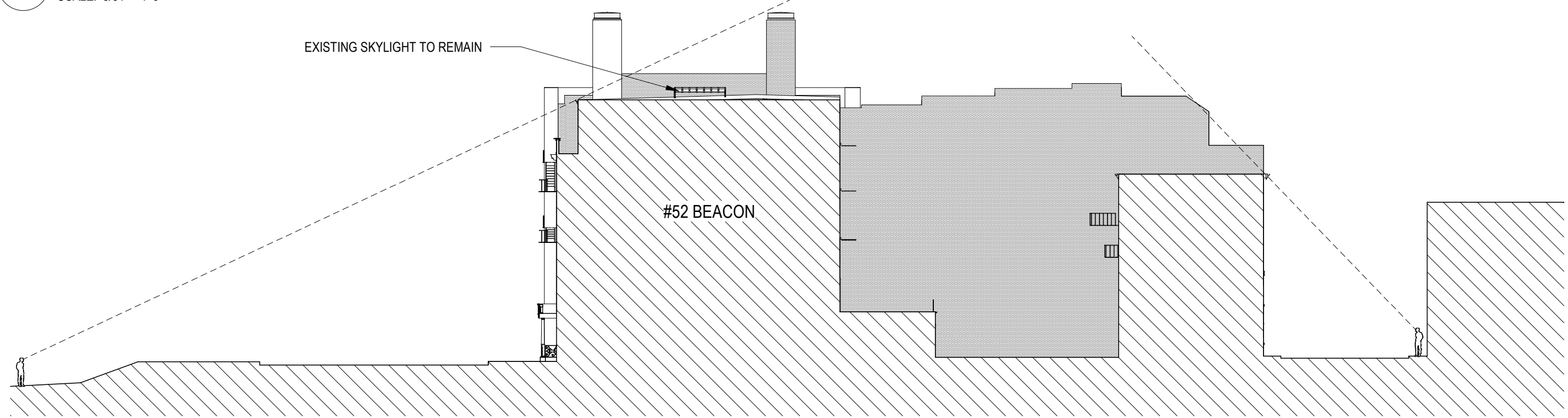

2 SITE SECTION 2 EXISTING
 SCALE: 3/64" = 1'-0"

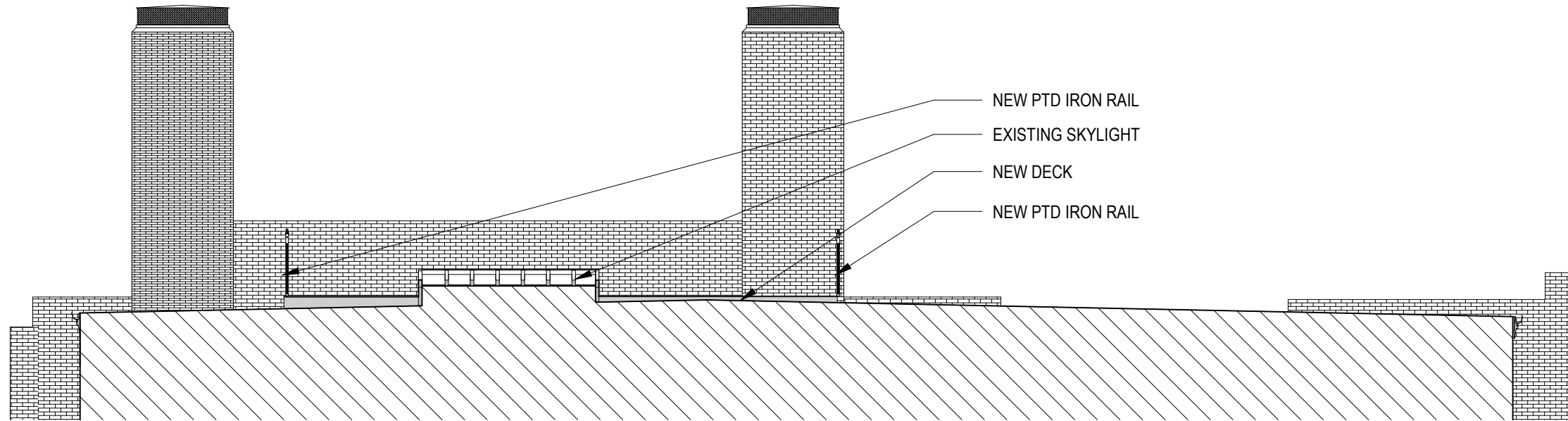

1

**BEACON STREET ROOF
SECTION LOOKING WEST**

SCALE: 1/8" = 1'-0"

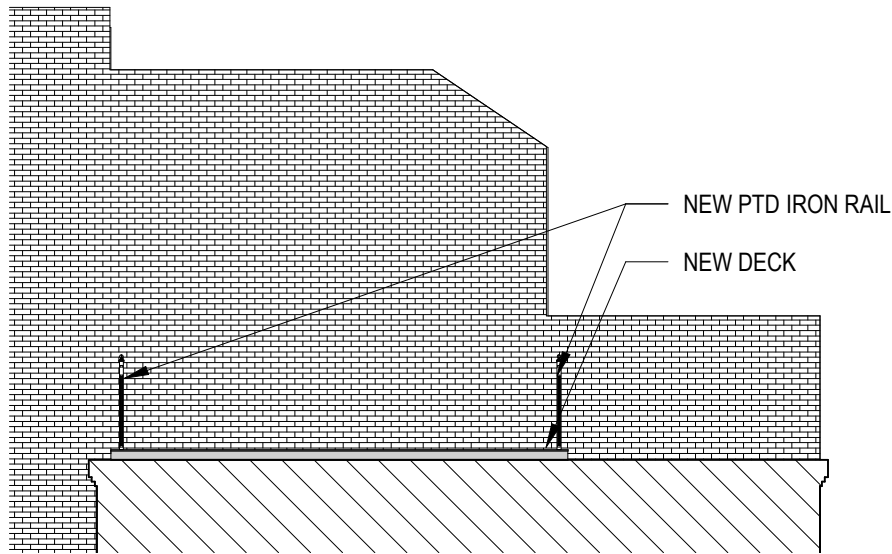

2

**BRANCH STREET ROOF
SECTION LOOKING WEST**

SCALE: 1/8" = 1'-0"

ENLARGED ROOF SECTION LOOKING WEST

Scale: 1/8" = 1'-0"

Date: 11/29/16



1 EXISTING BEACON STREET
SCALE:



2 PROPOSED BEACON STREET
SCALE:



3 EXISTING BRANCH STREET
SCALE:

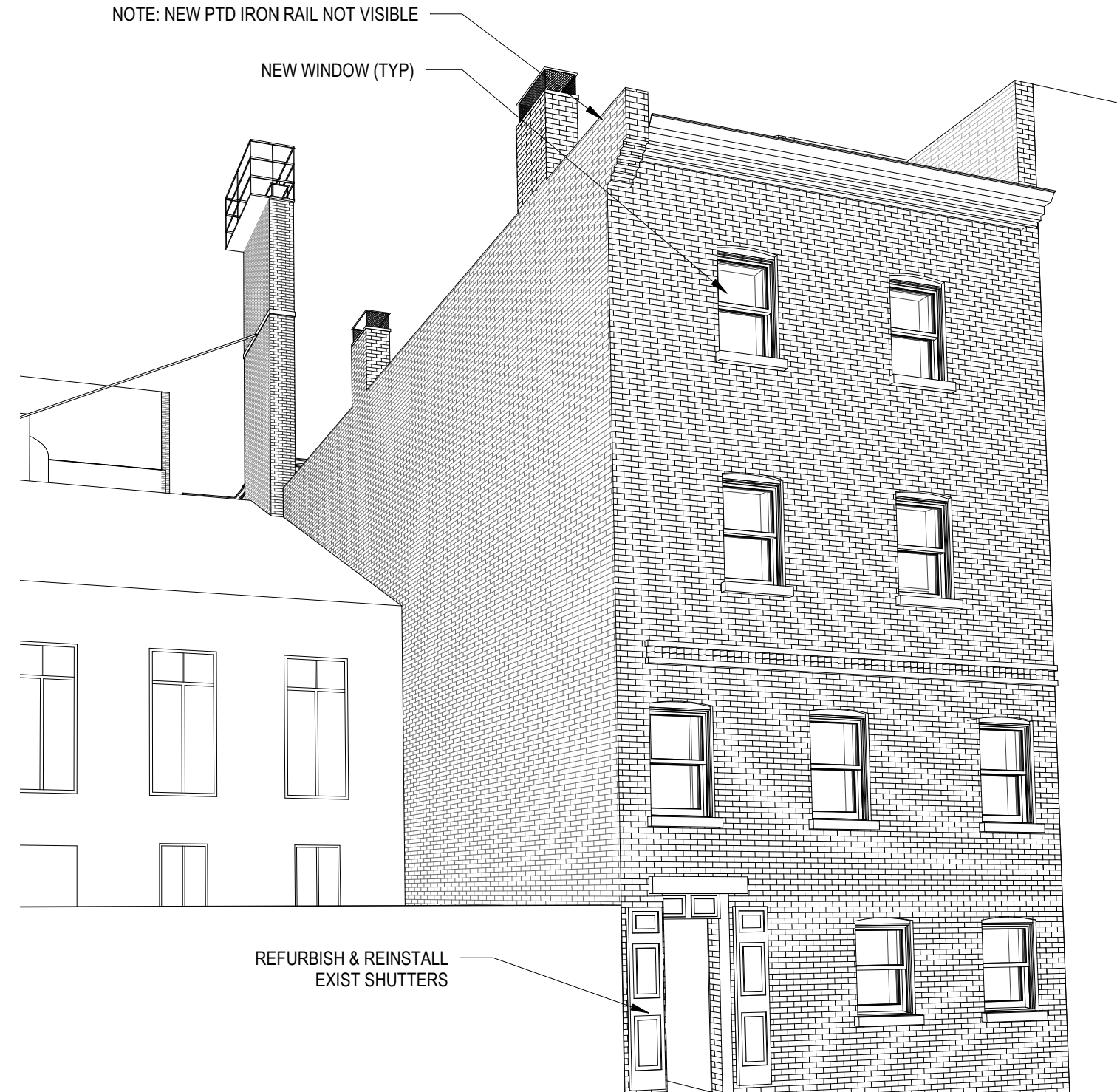

2 PROPOSED BRANCH STREET
SCALE:

NOTE: ADJACENT BUILDINGS REMOVED FOR CLARITY,
NOT POSSIBLE TO SEE ROOF OF 52 BEACON IN REALITY

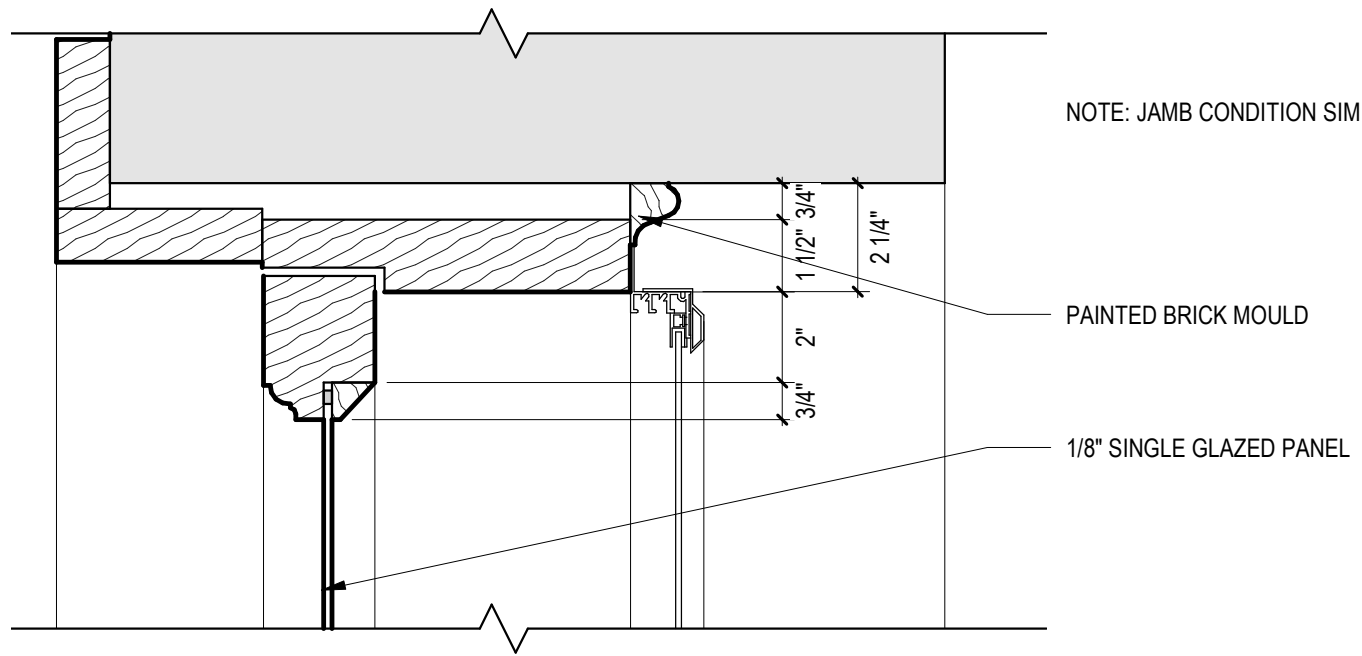

INTERIOR

EXTERIOR

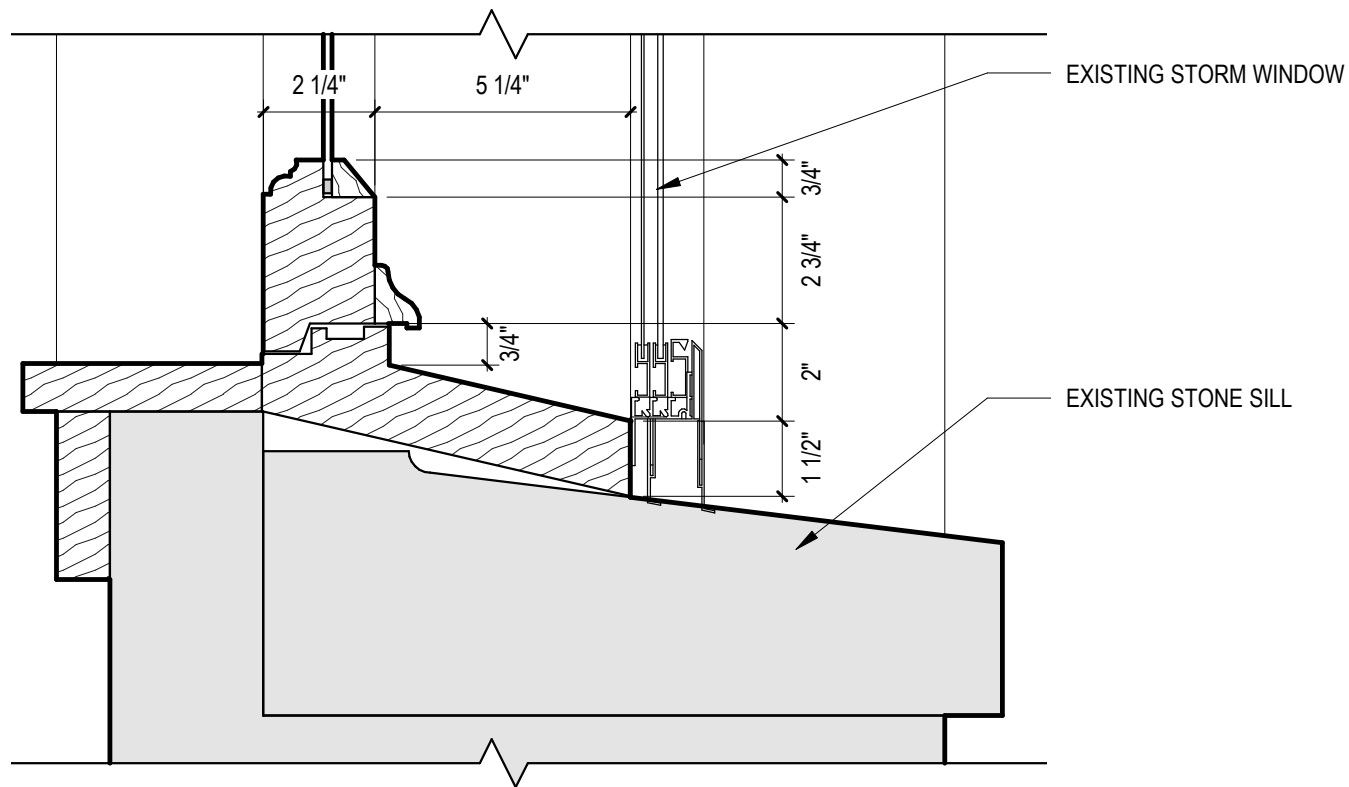

1 A2 - EXISTING HEAD & SILL (1st FLOOR)
SCALE: 3" = 1'-0"

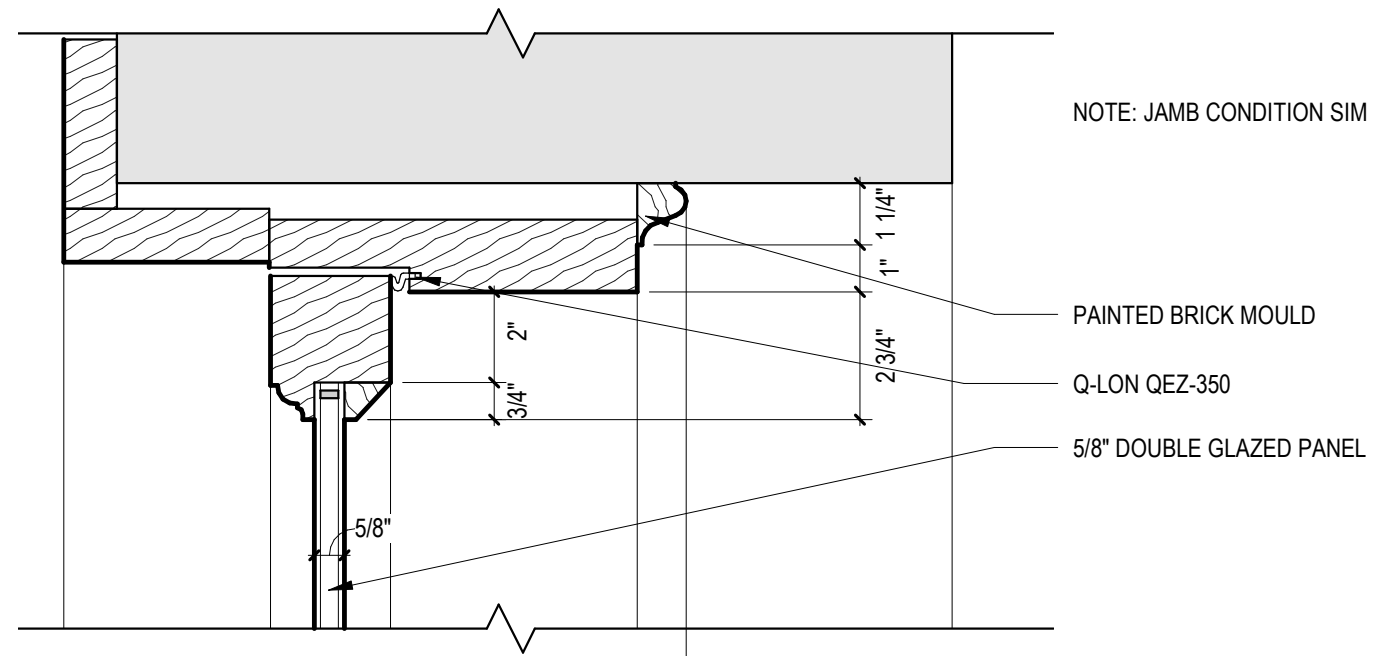

INTERIOR

EXTERIOR

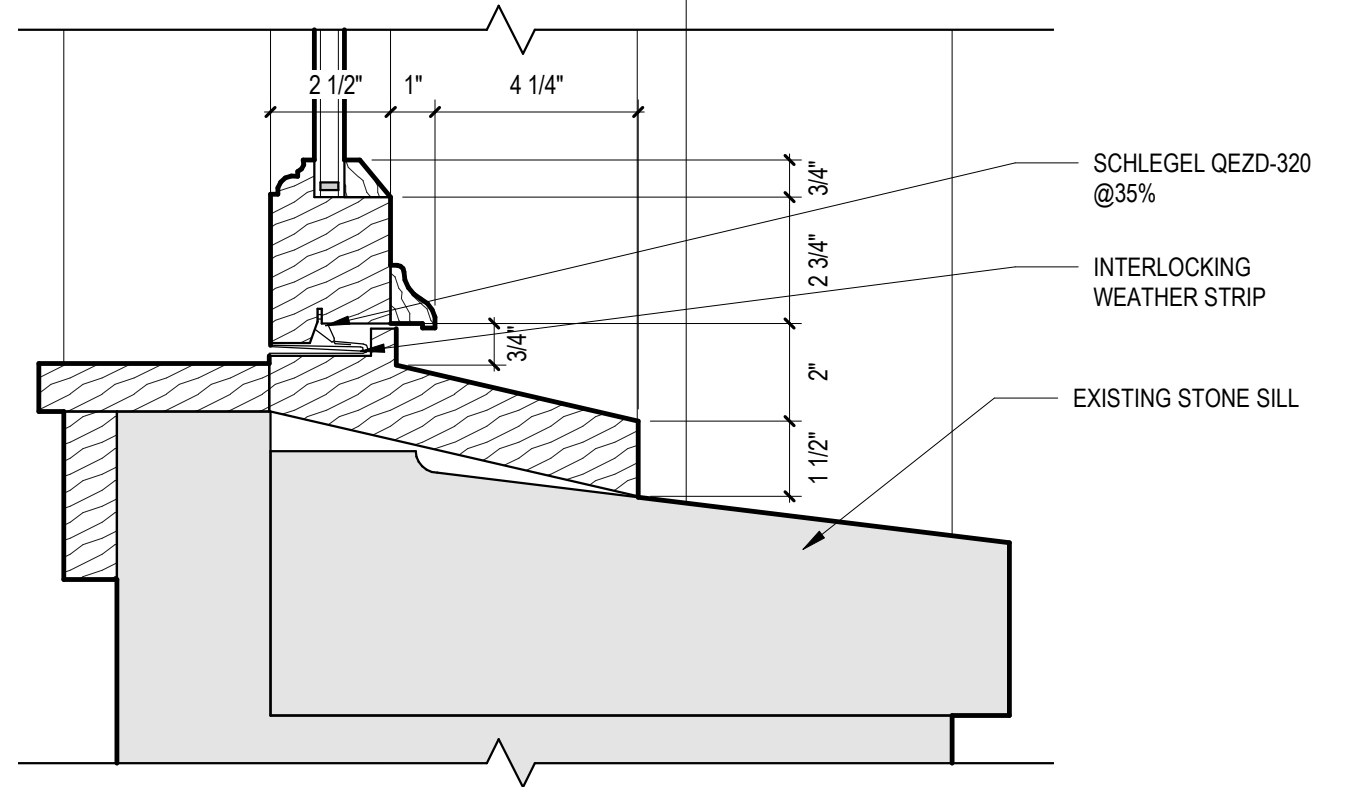

2 A2 - PROPOSED HEAD & SILL (1st FLOOR)
SCALE: 3" = 1'-0"



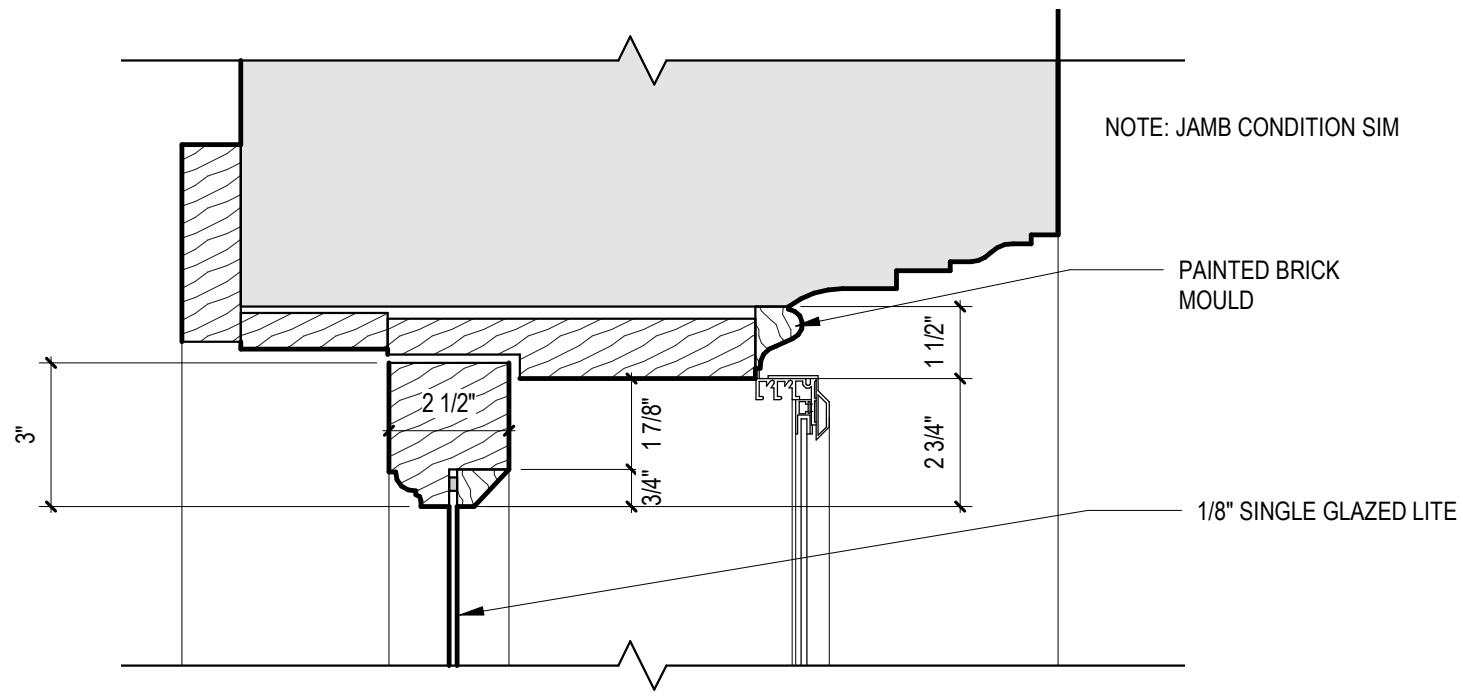

INTERIOR

EXTERIOR

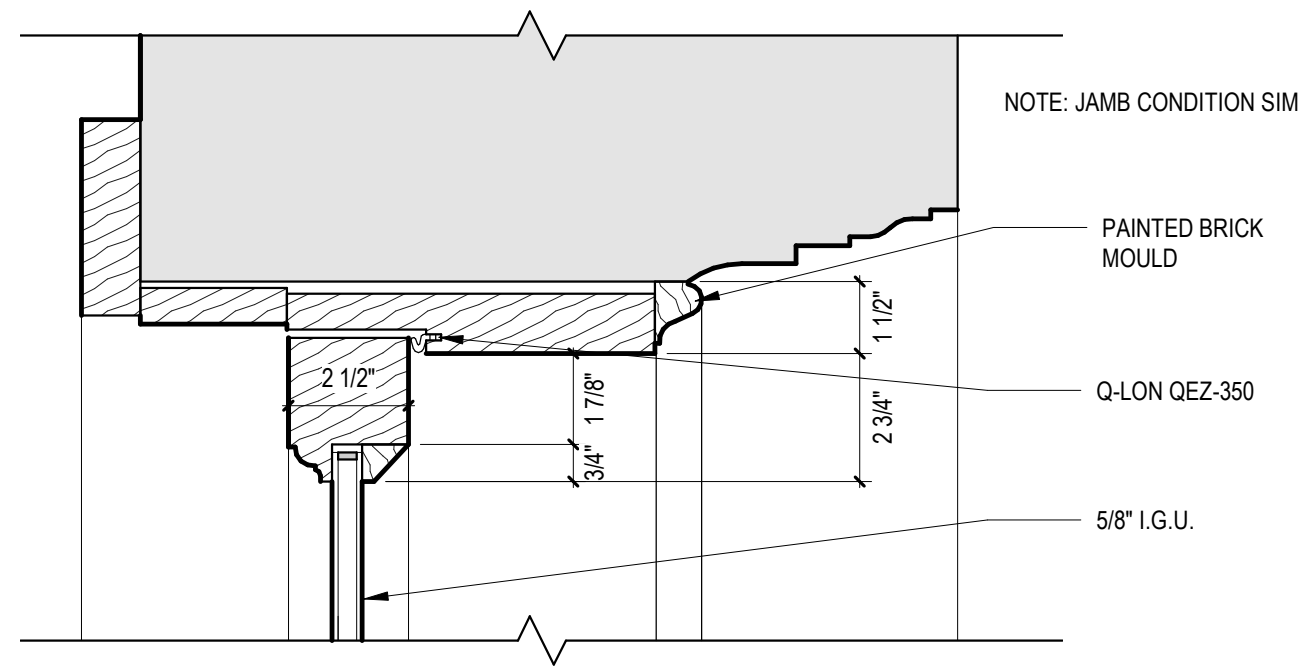

INTERIOR

EXTERIOR

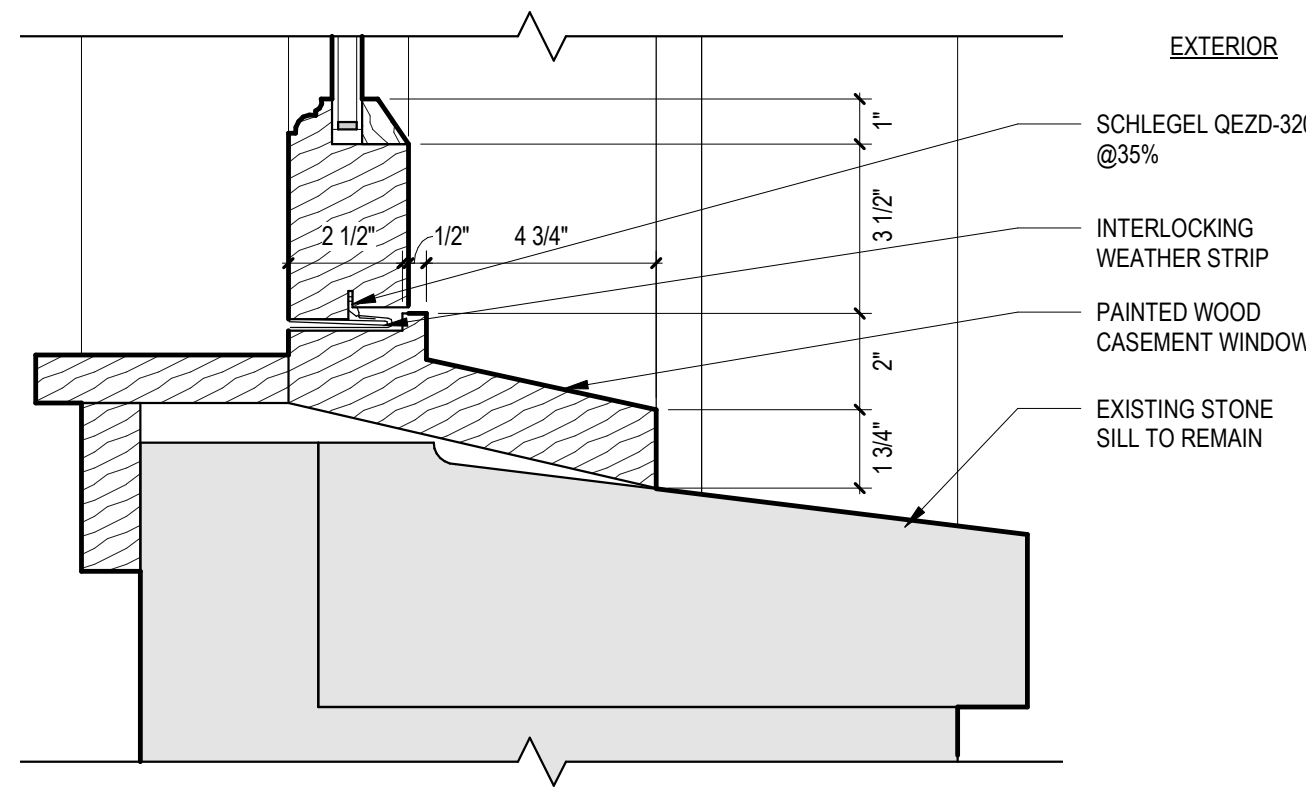
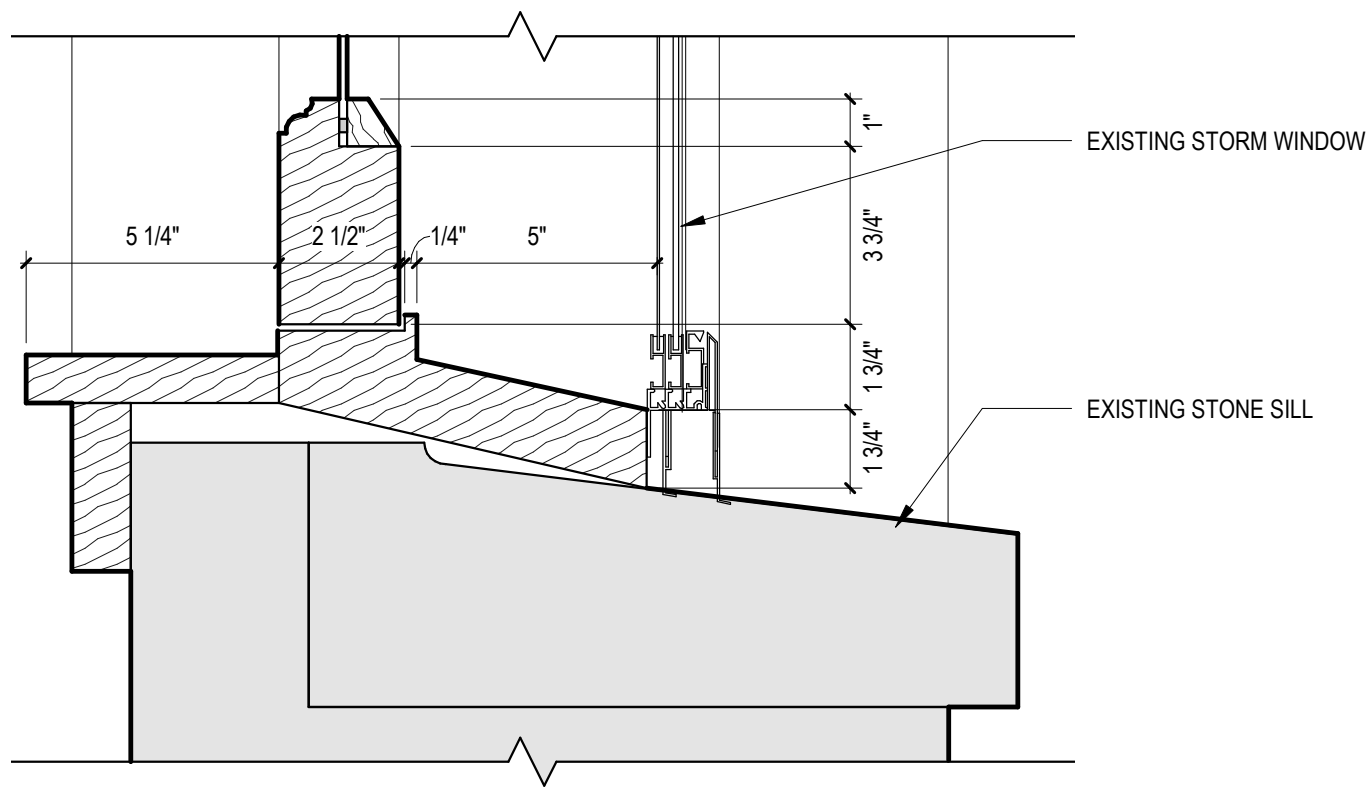

1 A1 - EXISTING HEAD & SILL (FLOORS 2 - 4)
SCALE: 3" = 1'-0"

2 A1 - PROPOSED HEAD & SILL (FLOORS 2 - 4)
SCALE: 3" = 1'-0"

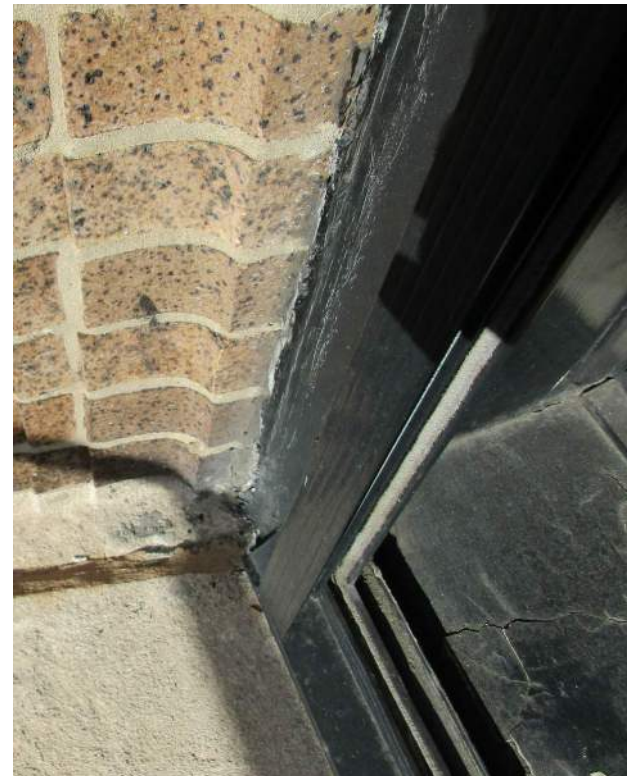

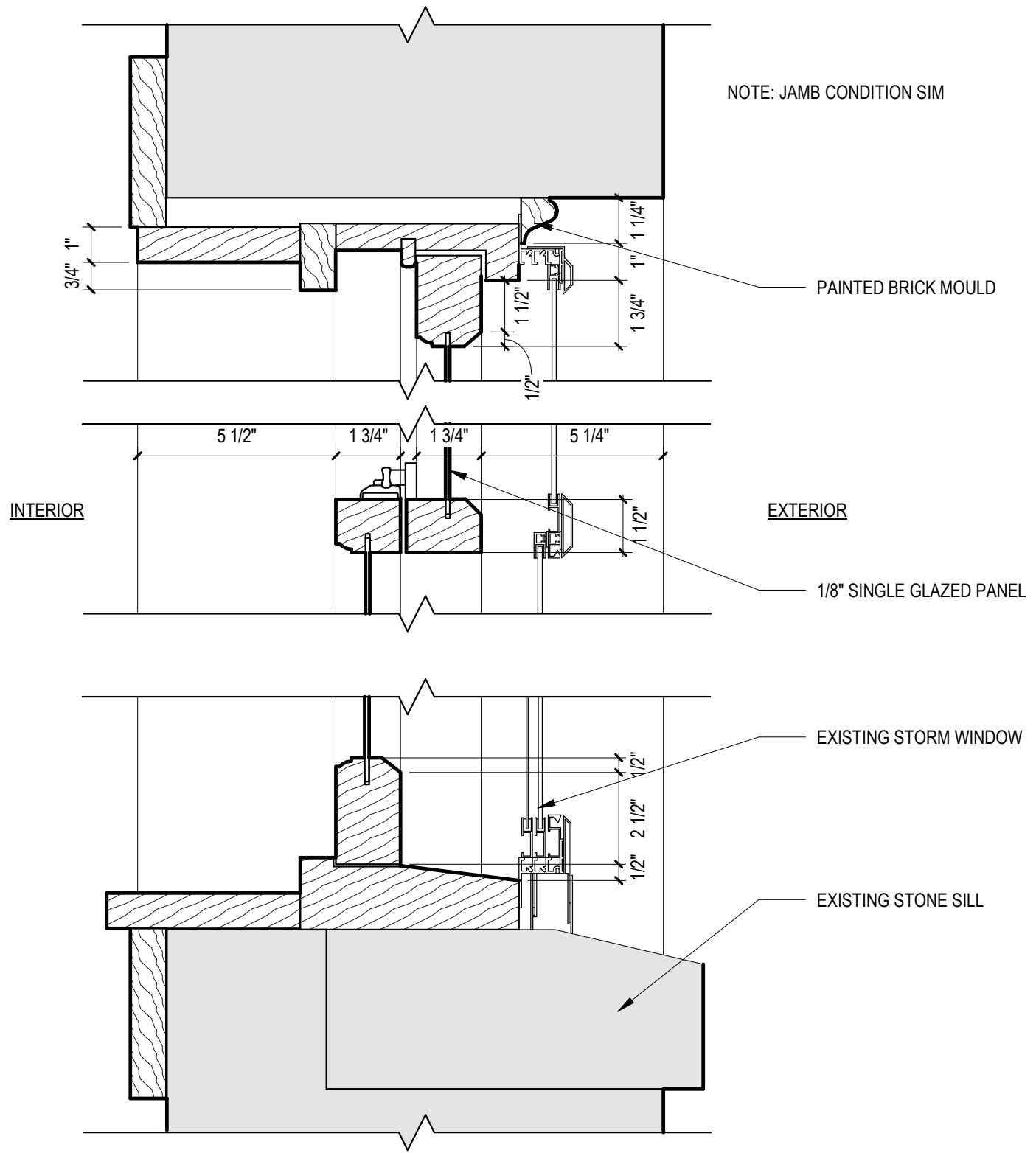

1 B - EXISTING HEAD & SILL
SCALE: 3" = 1'-0"

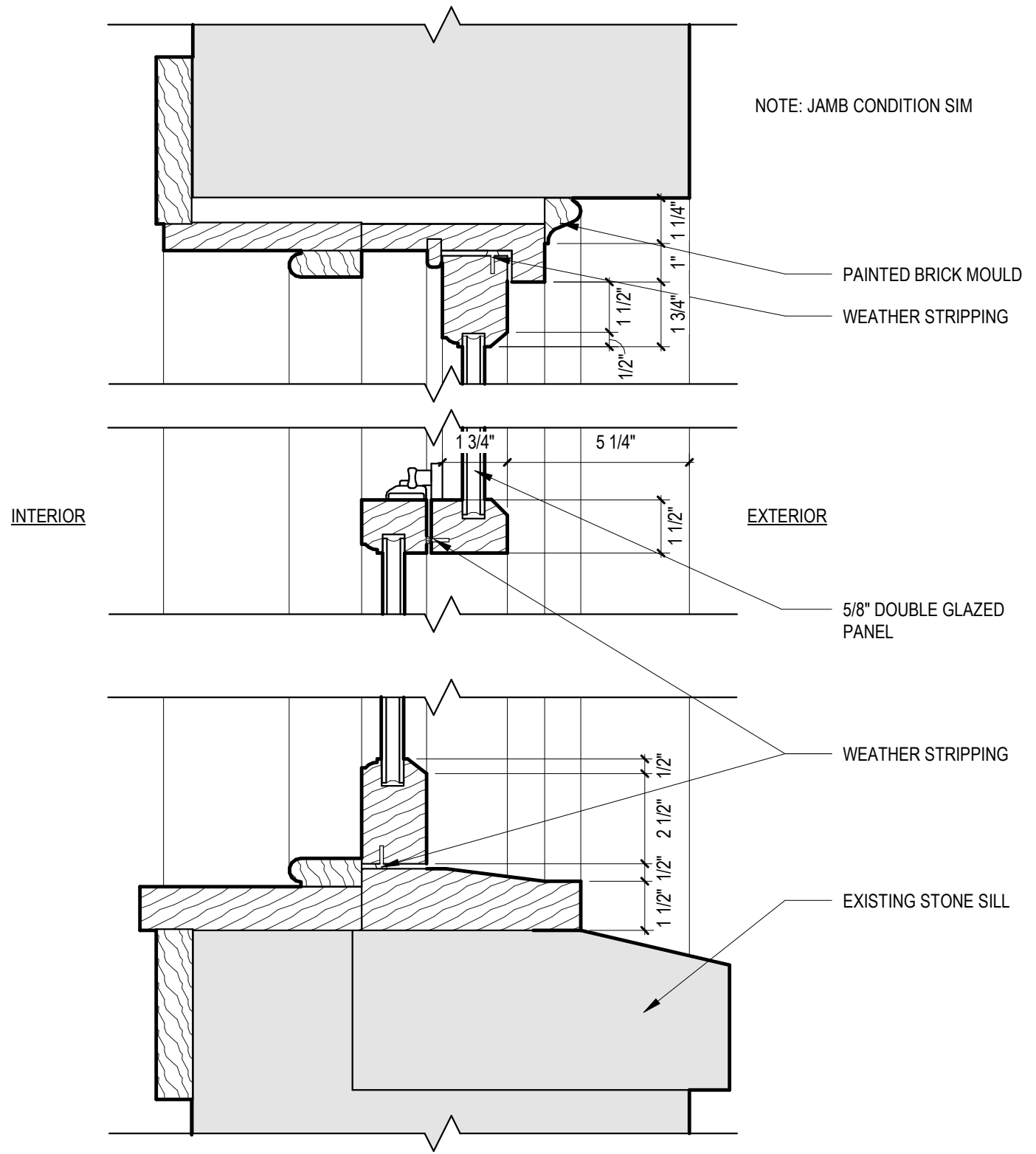

2 B - PROPOSED HEAD & SILL
SCALE: 3" = 1'-0"

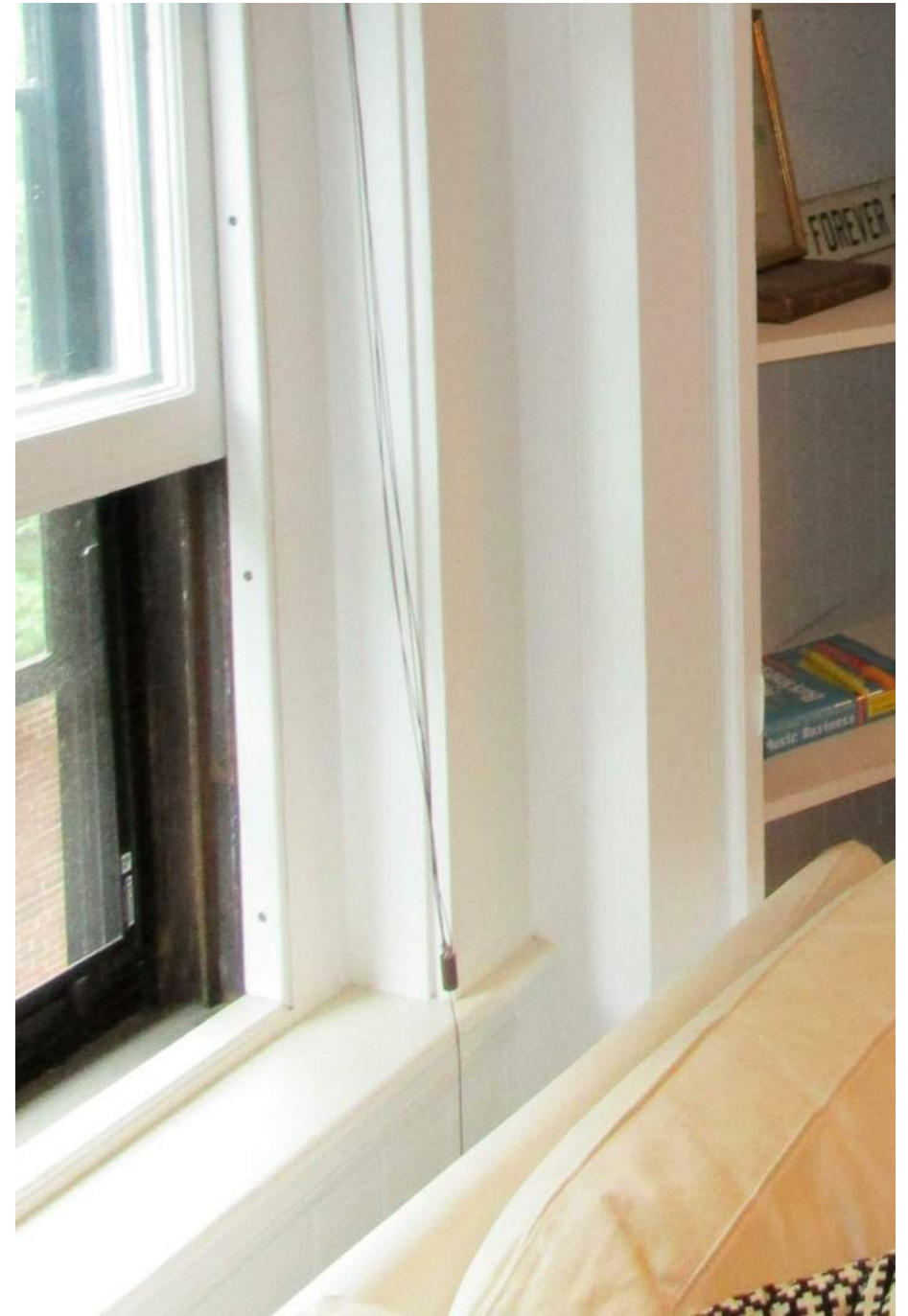

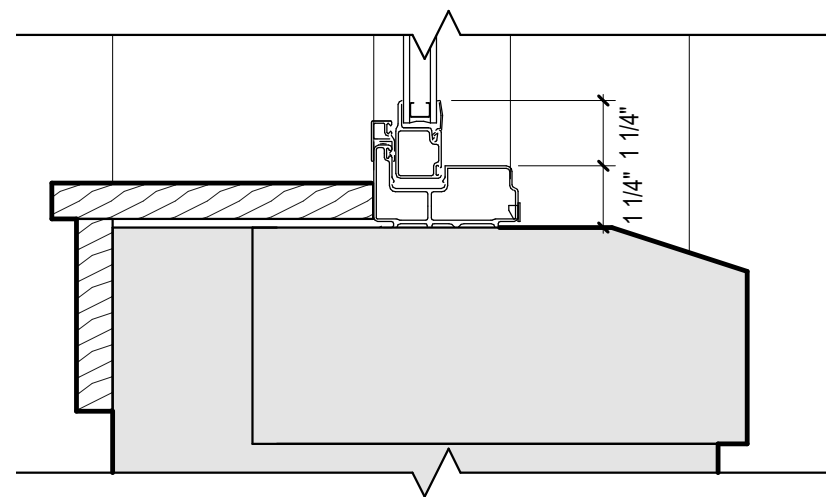
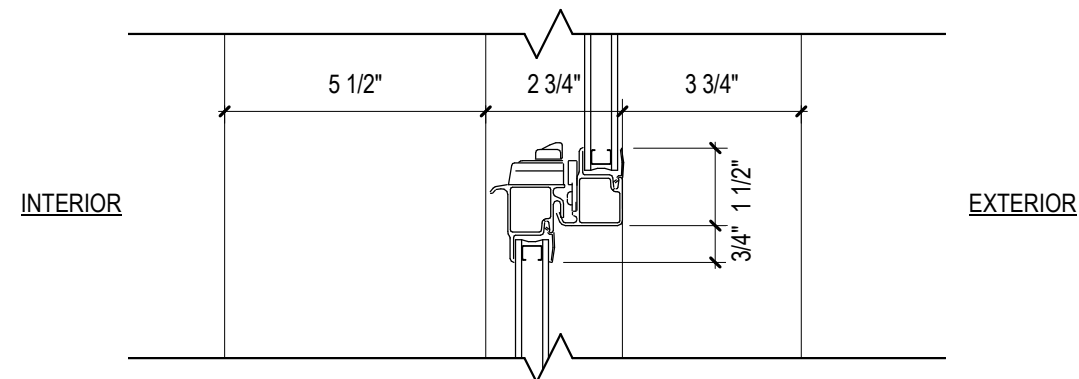
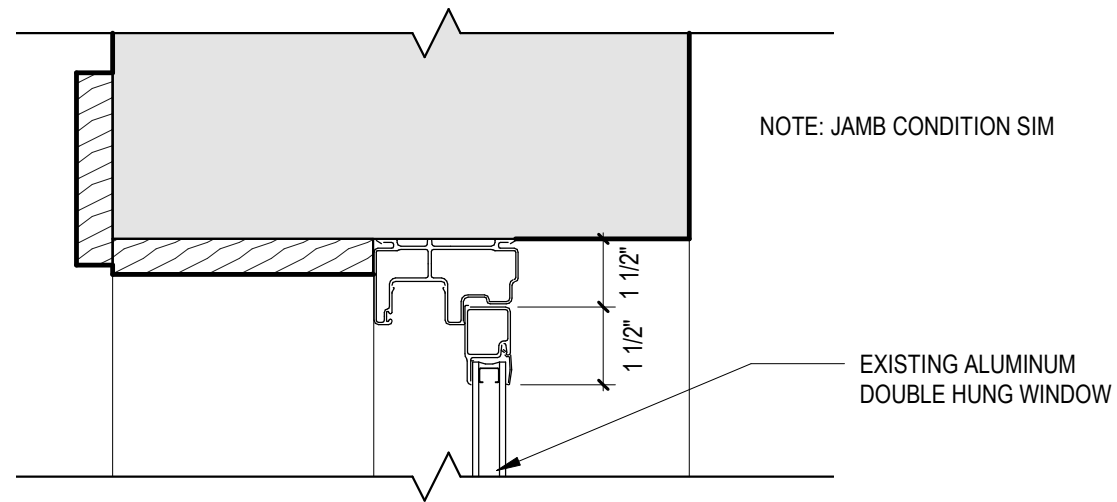

1 C- EXISTING HEAD & SILL
SCALE: 3" = 1'-0"

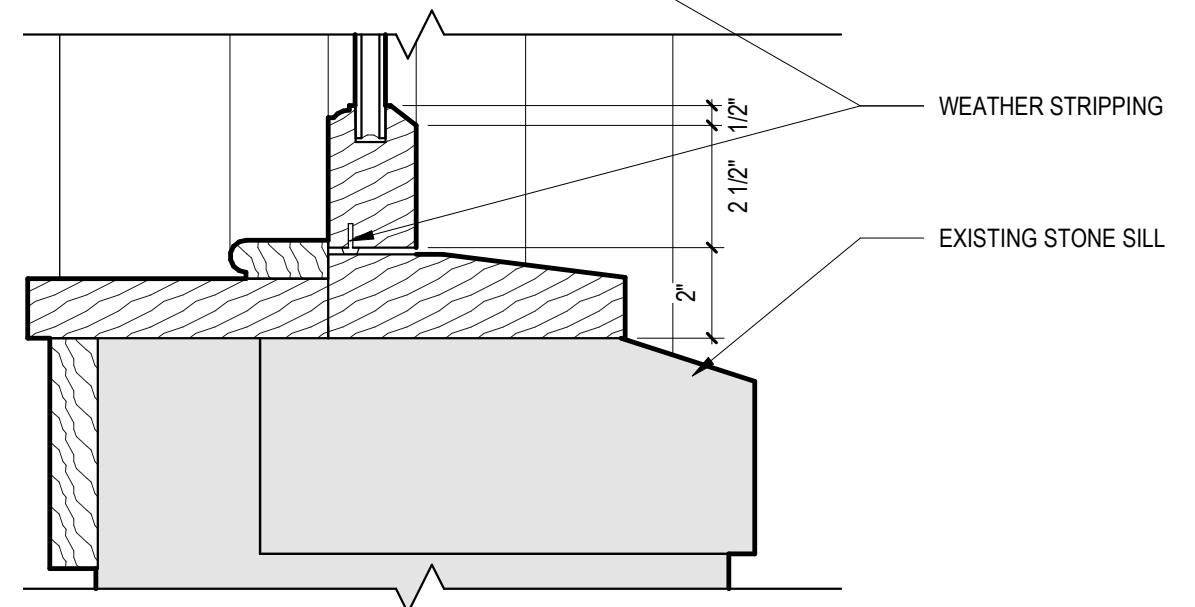
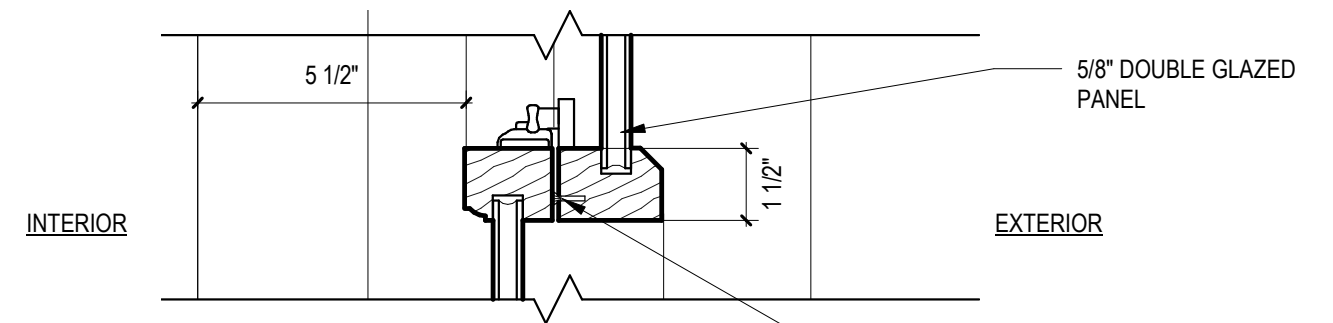
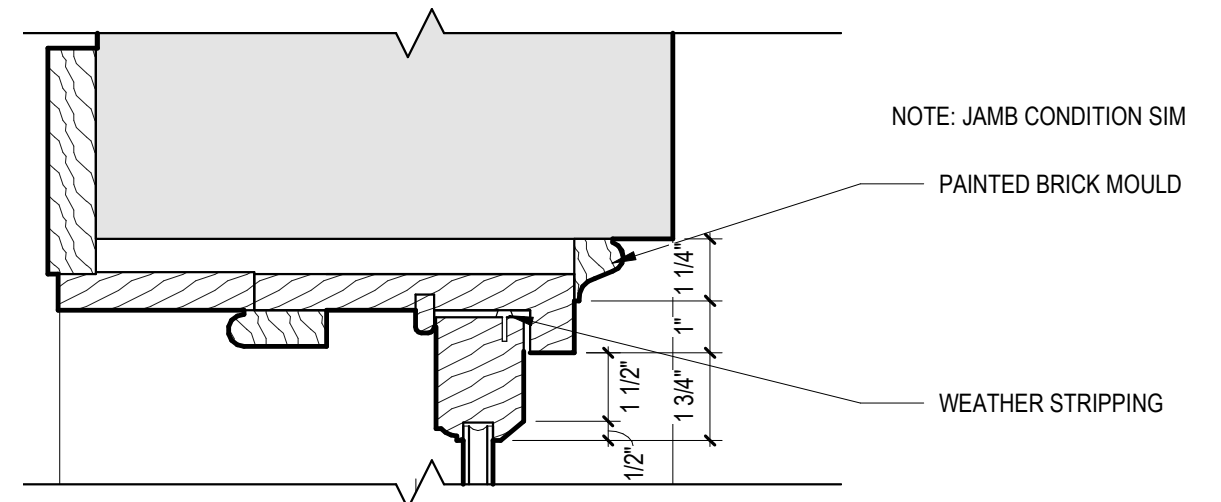

2 C - PROPOSED HEAD & SILL
SCALE: 3" = 1'-0"





FRONT RAIL VISIBLE FROM
BOSTON COMMON

