

1 EXISTING ROOF PLAN
1/8" = 1'-0"

UNIT 2

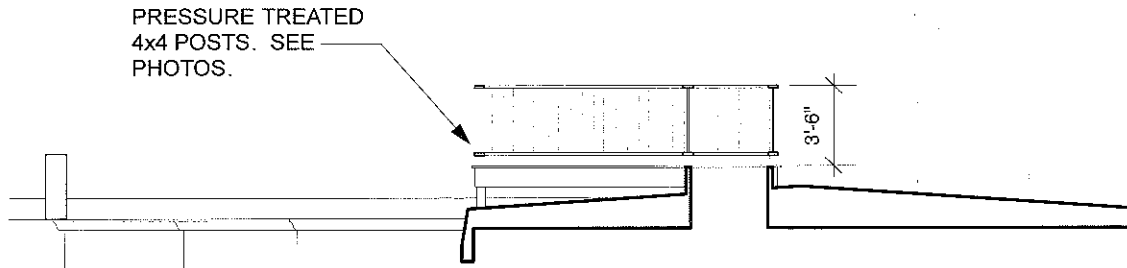

2 EXISTING DECK SECTION
1/8" = 1'-0"

NOTES:
SEE PHOTOS FOR
EXISTING RIALING
DETAILS.

SEE DRWG'S 7-10 FOR
ELEVATIONS

13 Walnut Street
Beacon Hill
Boston - 03/26/17

EXISTING Deck Drawings



Steven Young, Architect
617.645.0374
shimspace.com

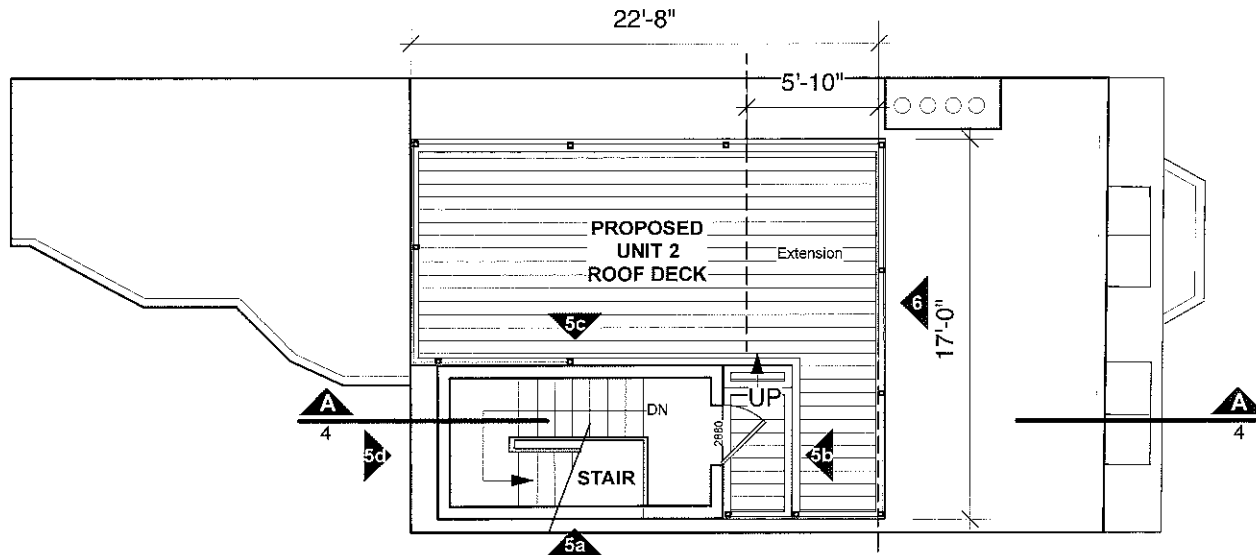

3 PROPOSED ROOF PLAN
1/8" = 1'-0"

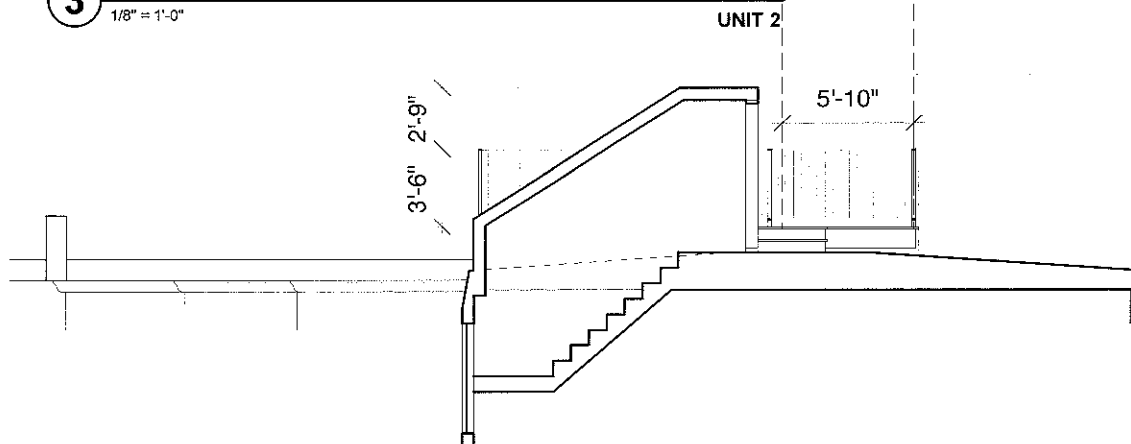

4 PROPOSED DECK + HEADHOUSE SECTION
1/8" = 1'-0"

NOTES:
NEW LOW-PROFILE
HEADHOUSE DOES
NOT INCREASE LIVING
AREA AND IS USED
SOLELY FOR ROOF
ACCESS.

SEE DRWG'S 11-14
FOR ELEVATIONS



13 Walnut Street
Beacon Hill
Boston - 03/26/17

PROPOSED Deck Drawings

Steven Young, Architect
617.645.0374
shimspace.com

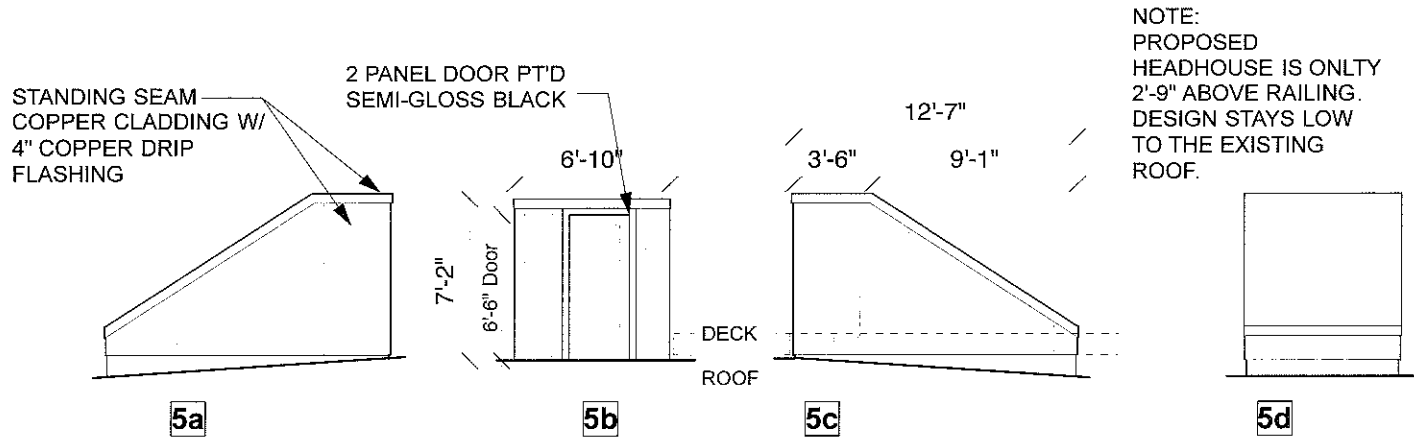

5 PROPOSED LOW PROFILE HEADHOUSE ELEVATIONS

1/8" = 1'-0"

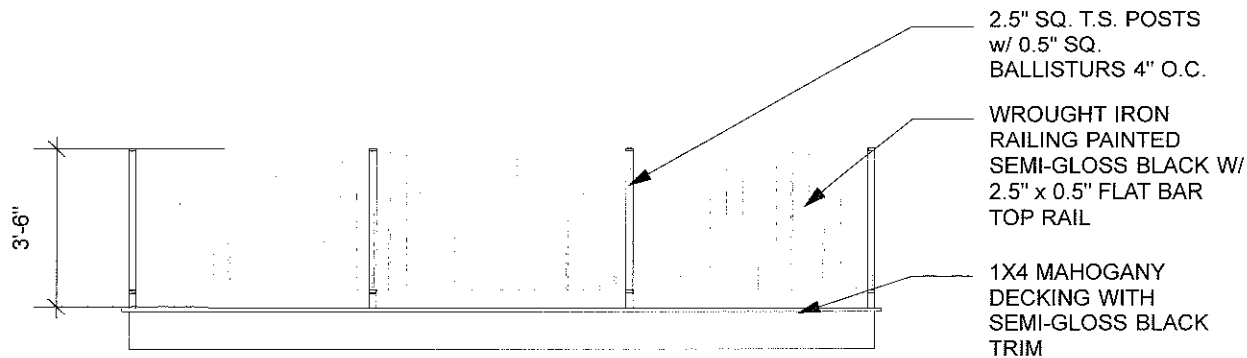

6 TYPICAL RAILING DETAILS

1/4" = 1'-0"

EXISTING PRESSURE TREATED RAILING



7 EXISTING SOUTH ELEVATION
1/8" = 1'-0"

EXISTING P.T. RAILING SYSTEM

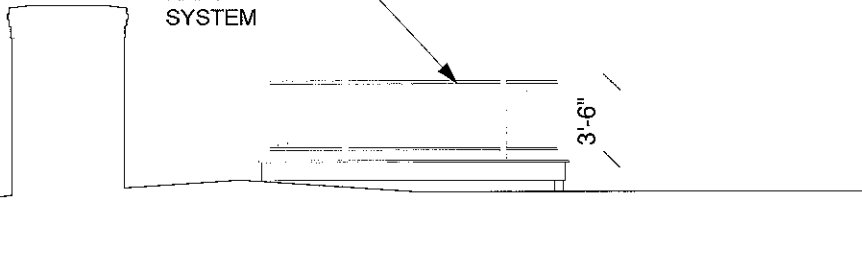

8 EXISTING NORTH ELEVATION
1/8" = 1'-0"

EXISTING P.T. RAILING SYSTEM

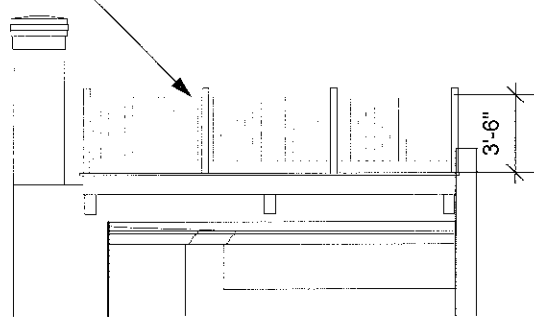

9 EXISTING WEST ELEVATION (REAR)
1/8" = 1'-0"

13 Walnut Street
Beacon Hill
Boston - 03/26/17

10 EXISTING EAST ELEVATION (FRONT)
1/8" = 1'-0"



EXISTING Deck Elevations

Steven Young, Architect
617.645.0374
shimspace.com

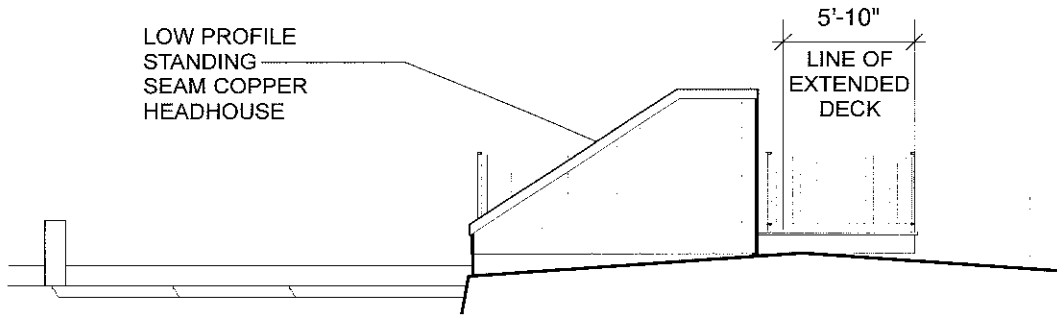

11 PROPOSED SOUTH ELEVATION
1/8" = 1'-0"

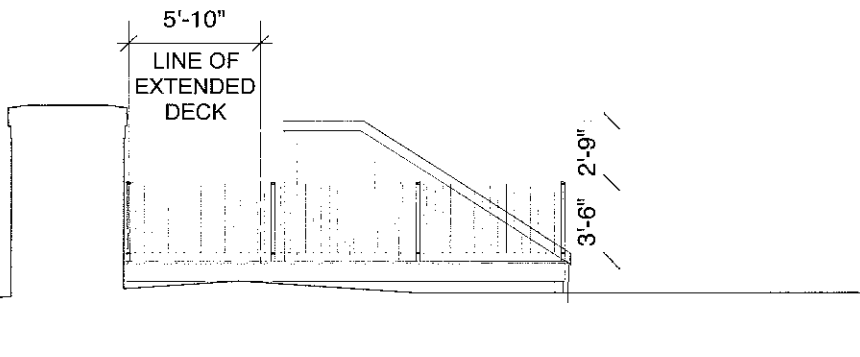

12 PROPOSED NORTH ELEVATION
1/8" = 1'-0"

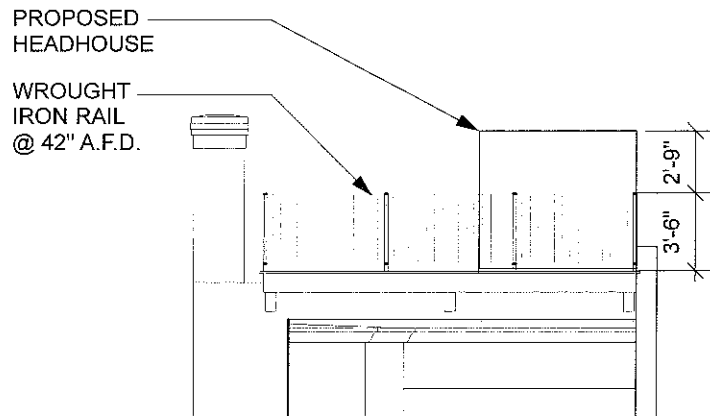

13 PROPOSED WEST ELEVATION (REAR)
1/8" = 1'-0"

14 PROPOSED EAST ELEVATION (FRONT)
1/8" = 1'-0"



13 Walnut Street
Beacon Hill
Boston - 03/26/17

PROPOSED Deck Elevations

Steven Young, Architect
617.645.0374
shimspace.com

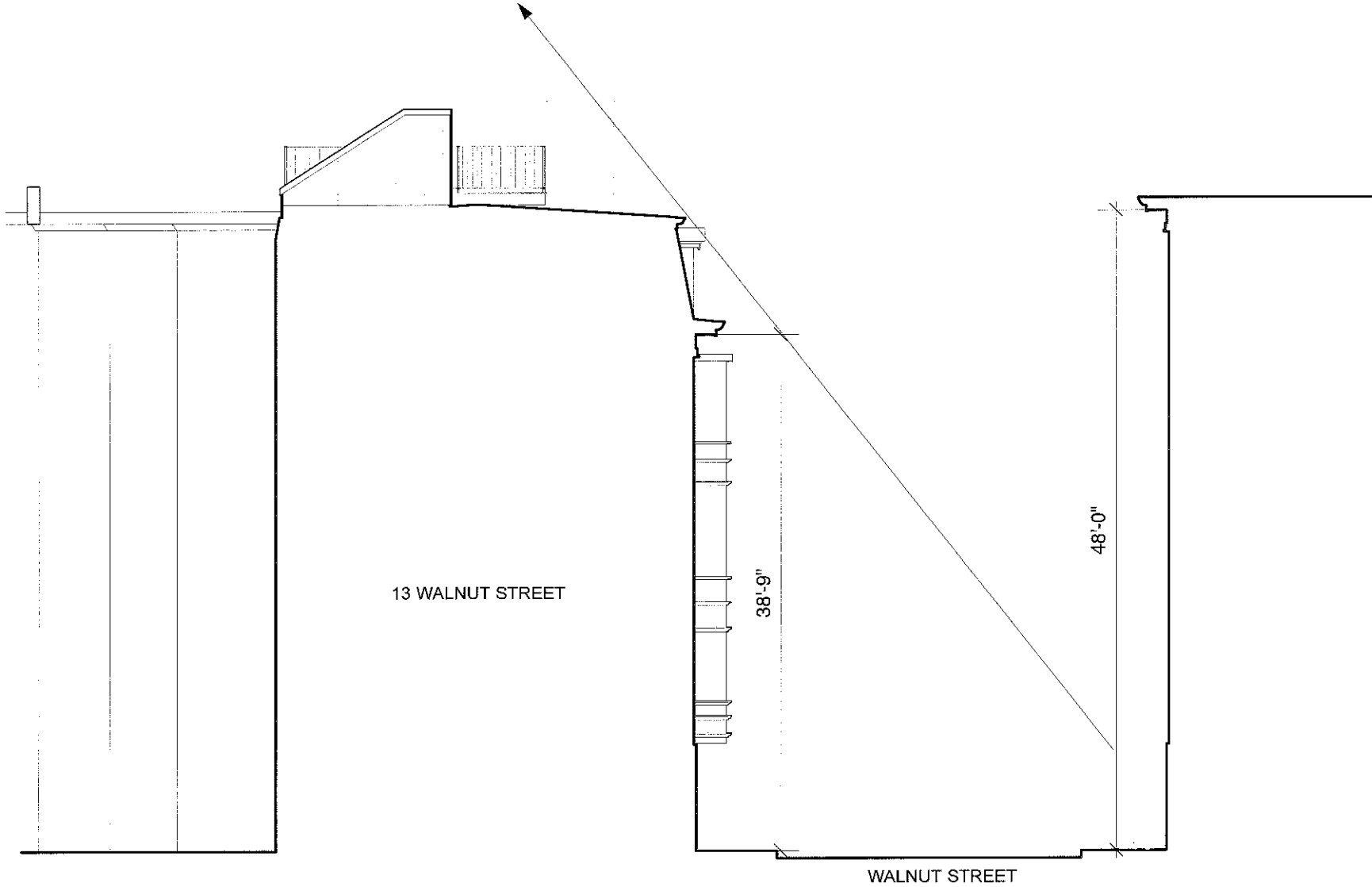

15 LINE OF SIGHT STREET SECTION
1/12" = 1'-0"

13 Walnut Street
 Beacon Hill
 Boston - 03/26/17

Proposed Deck Drawings

Steven Young, Architect
 617.645.0374
 shimspace.com

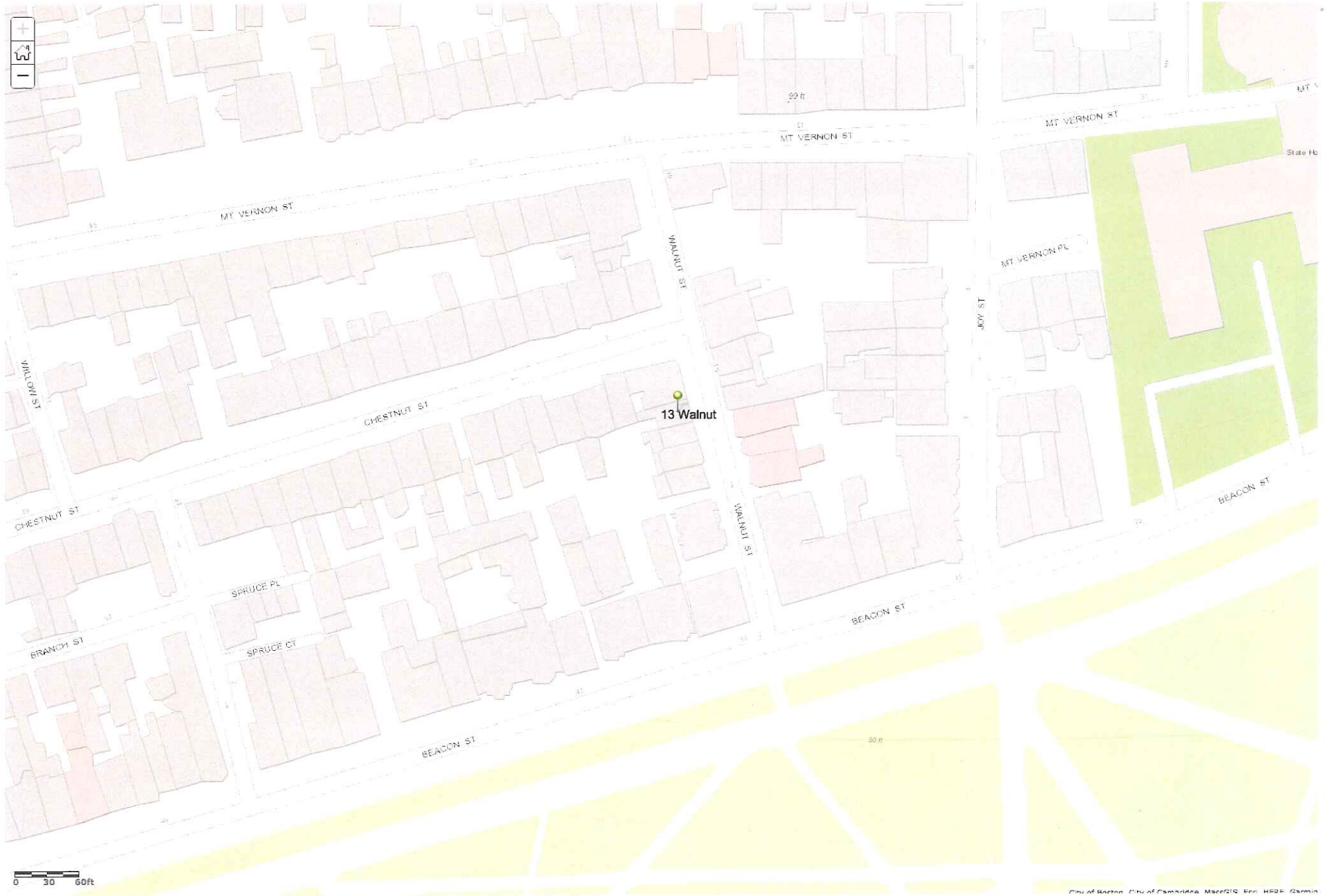

13 Walnut Street Block Map - March 28, 2017

City of Boston, City of Cambridge, MassGIS, Esri, HERE, Garmin



Close up photo (no zoom)
13 Walnut Street - Boston
March 28, 2017



Close up photo with Zoom
13 Walnut Street - Boston
March 28, 2017

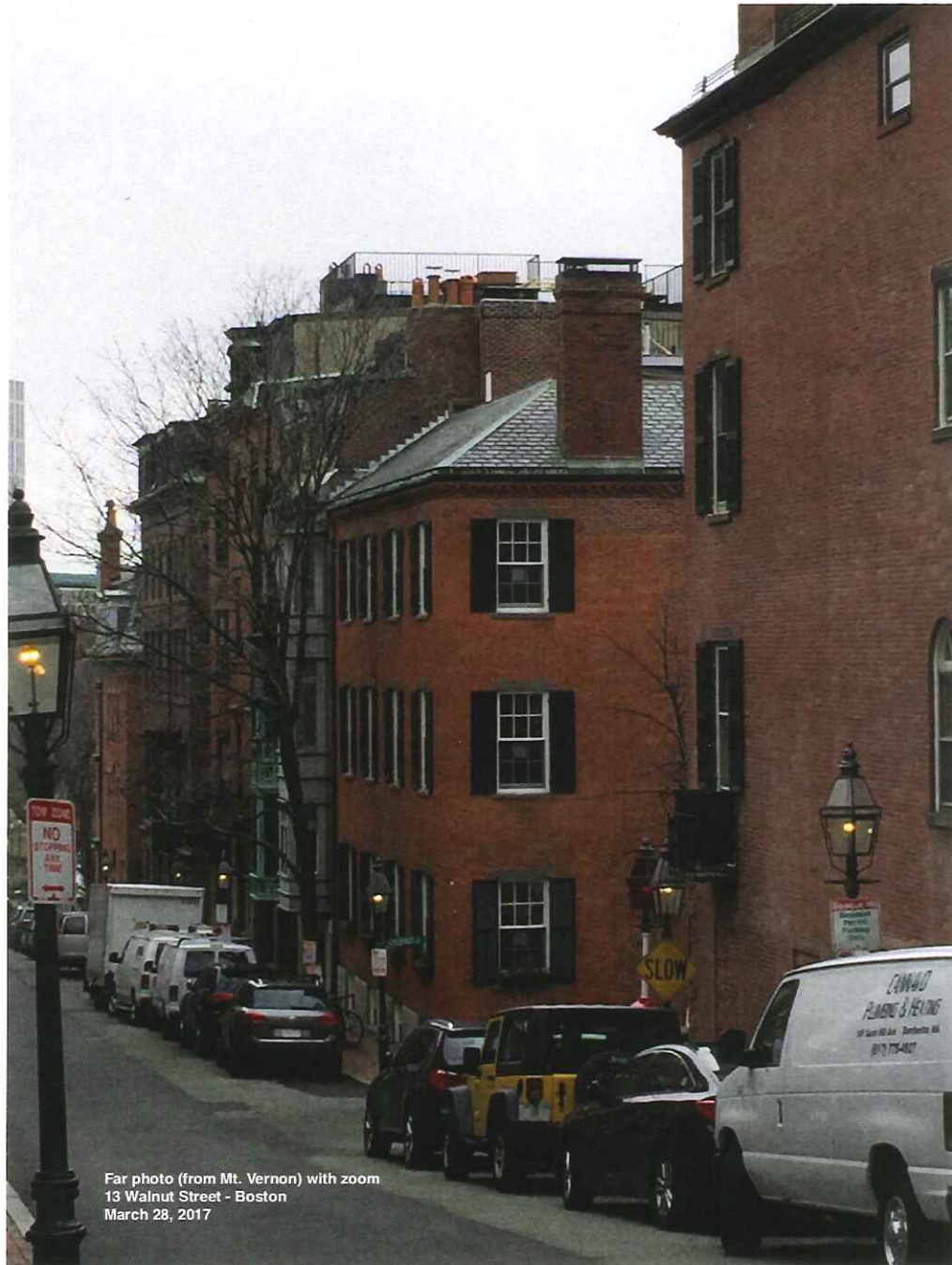

Far photo (from Mt. Vernon) with zoom
13 Walnut Street - Boston
March 28, 2017



Photo (East) of head house mock up and front railing extension
13 Walnut St. - Boston
March 28, 2017



Photo (East) of head house mock up
March 28, 2017
13 Walnut Street - Boston



Photo (North) of head house mock up
13 Walnut Street - Boston
March 28, 2017



Photo (South) of railing mock up
13 Walnut Street - Boston
March 28, 2017

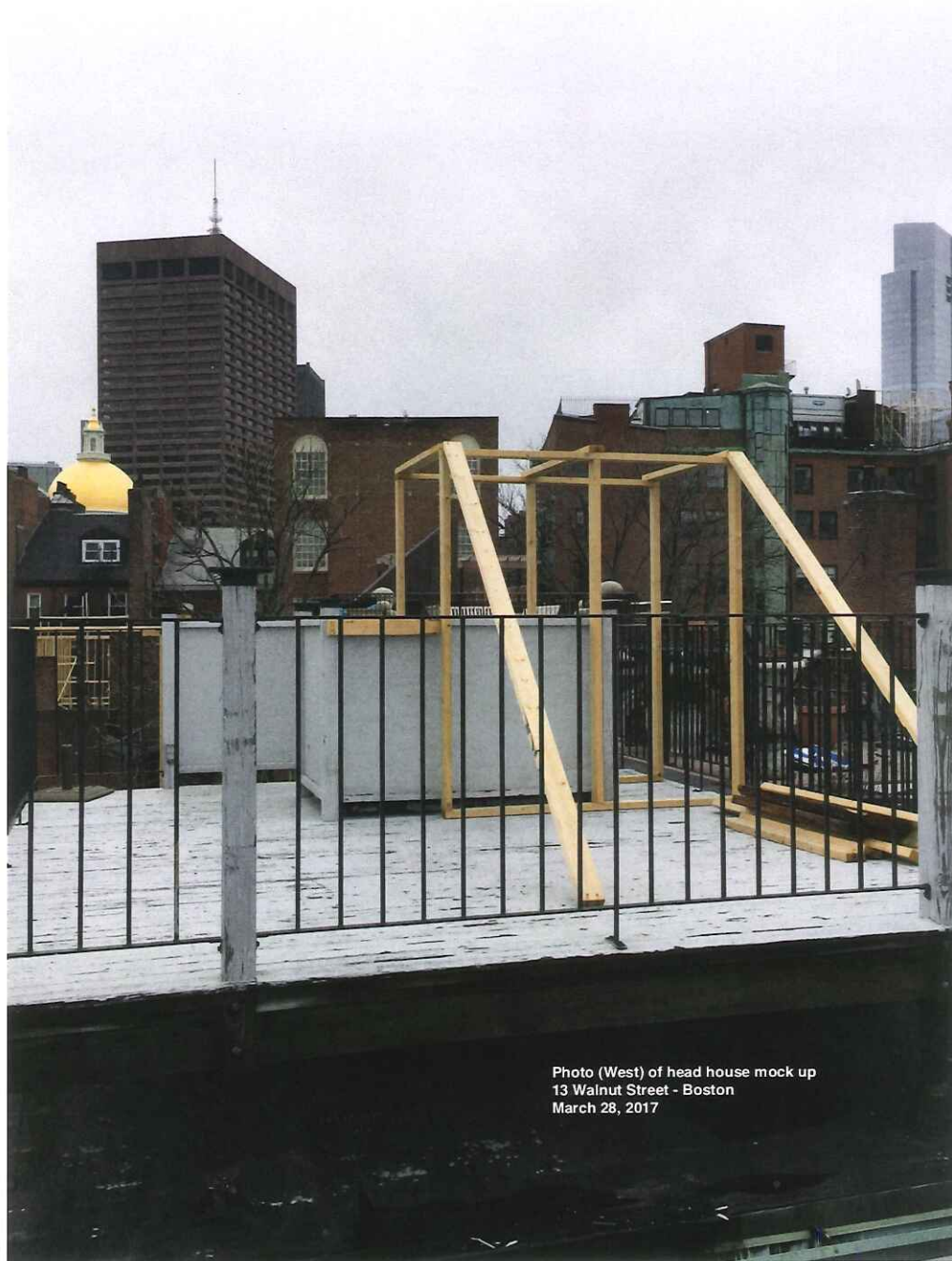

Photo (West) of head house mock up
13 Walnut Street - Boston
March 28, 2017