



VIEW 8



VIEW 8



VIEW 11



VIEW 11



VIEW 11



VIEW 11



VIEW 10



VIEW 10



VIEW 9

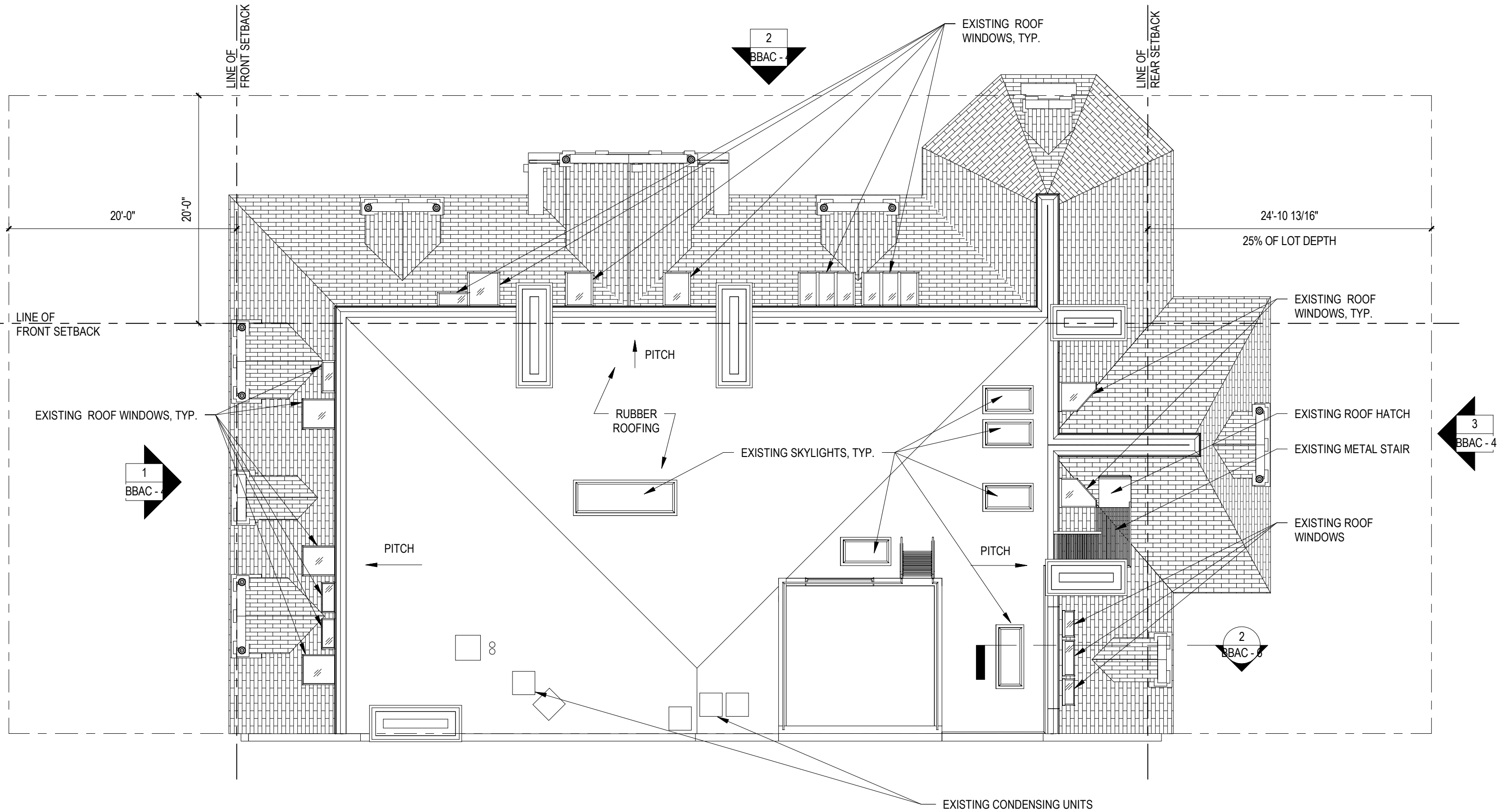

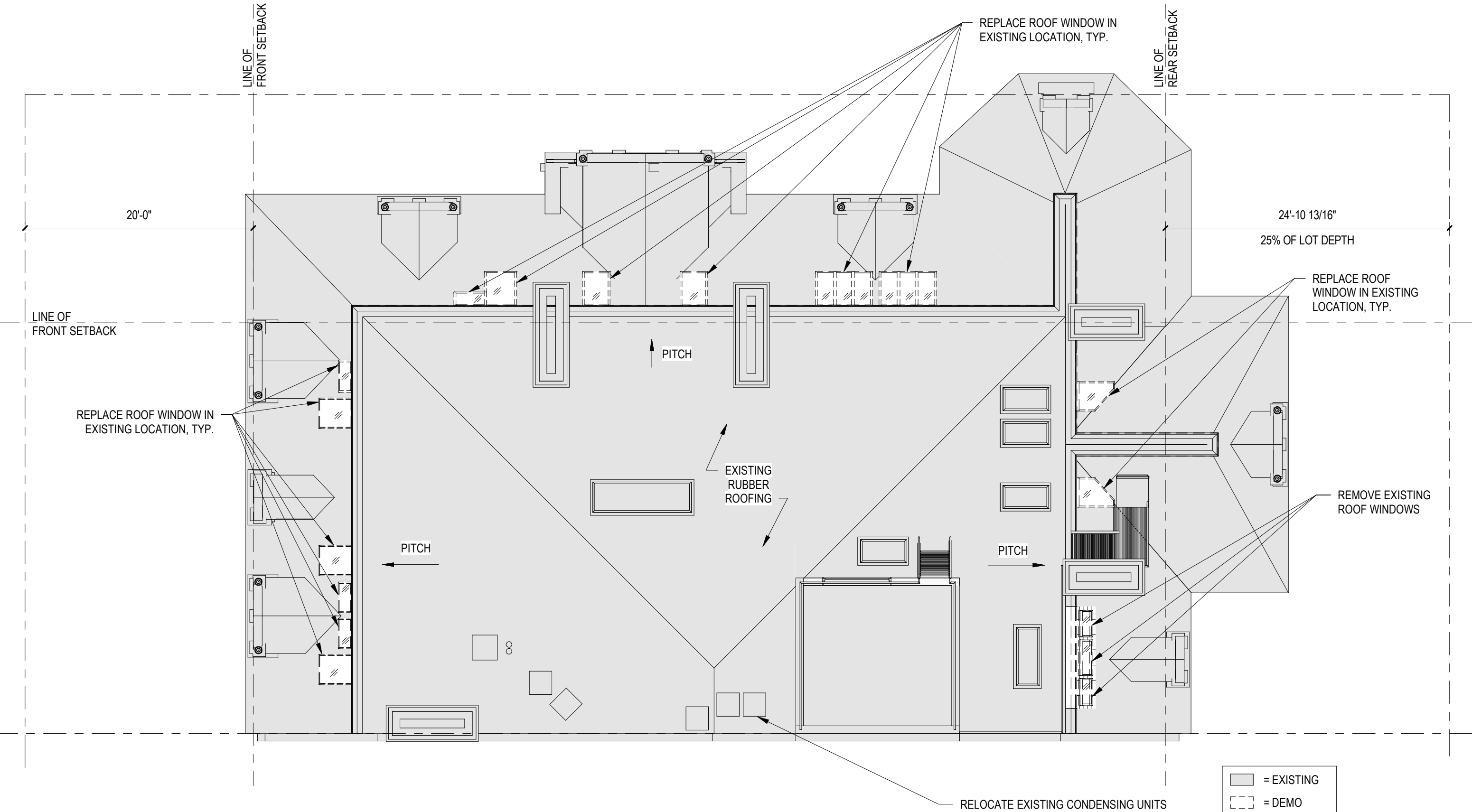

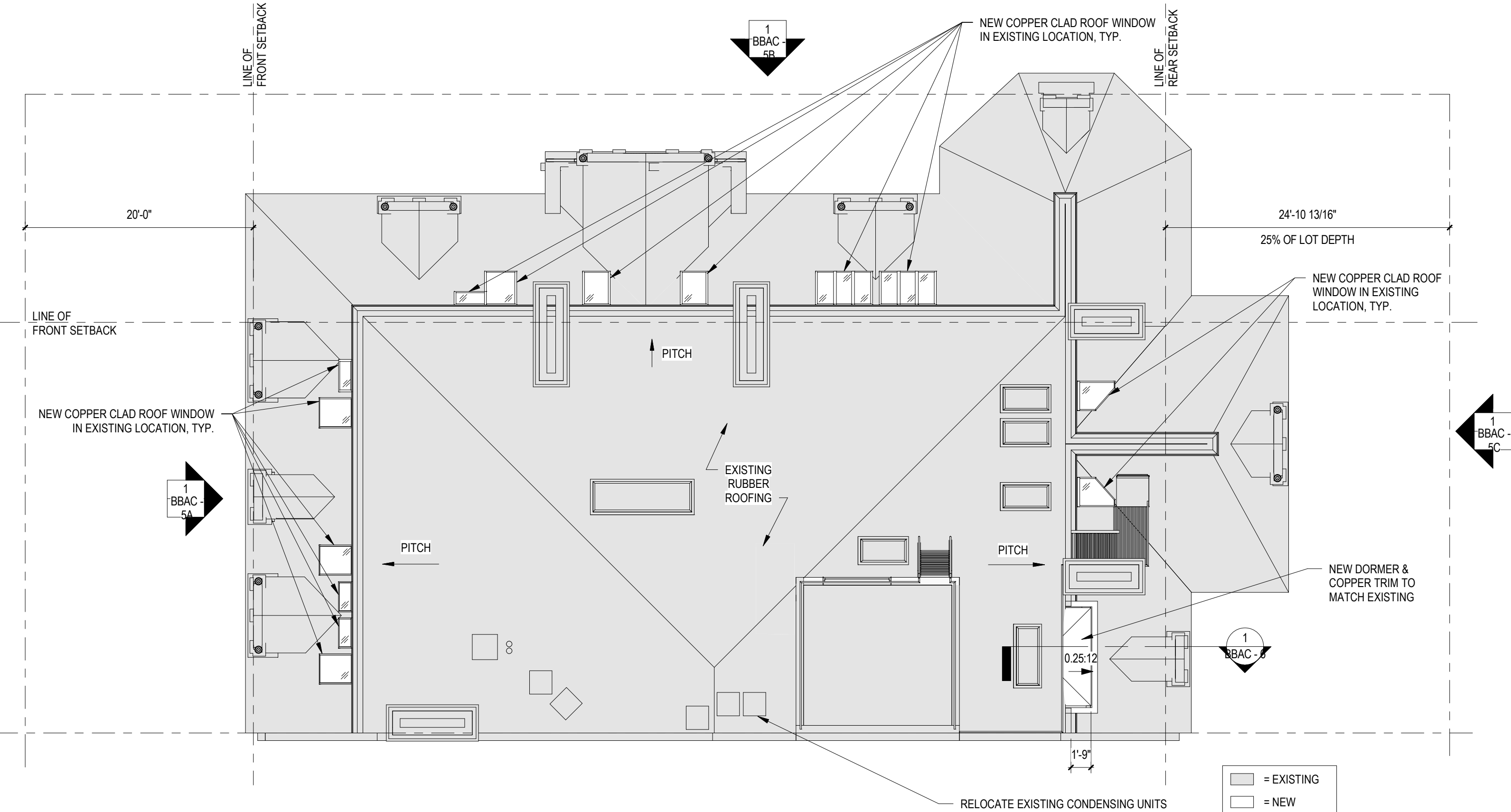

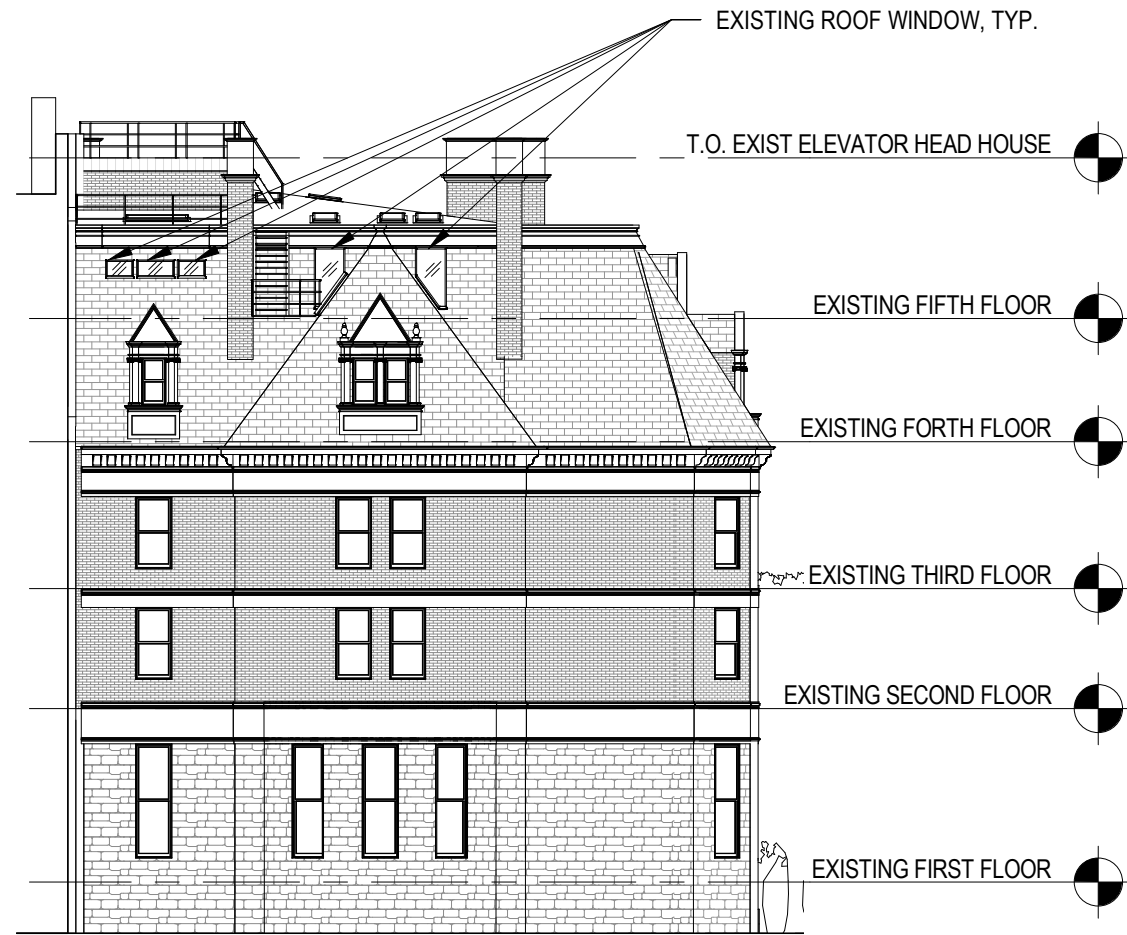

1 EXIST. COMM AVE ELEV.
SCALE: 1/16" = 1'-0"

2 EXIST. GLOUCESTER ST ELEV.
SCALE: 1/16" = 1'-0"

3 EXIST. PUBLIC ALLEY ELEV.
SCALE: 1/16" = 1'-0"





NEW COPPER CLAD ROOF WINDOW
IN EXISTING LOCATION, TYP.

T.O. EXIST ELEVATOR HEAD HOUSE

EXISTING FIFTH FLOOR

EXISTING FORTH FLOOR

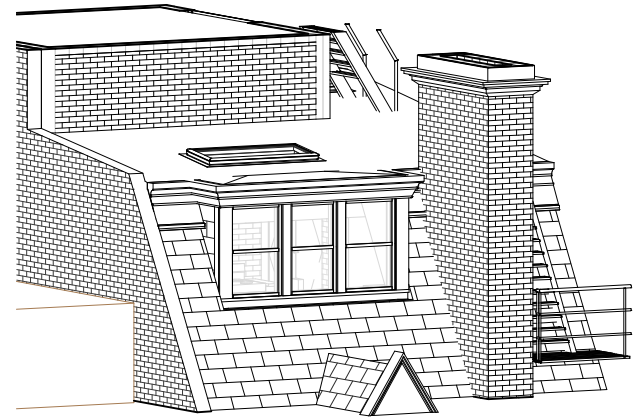

2 DORMER PERSPECTIVE
SCALE:

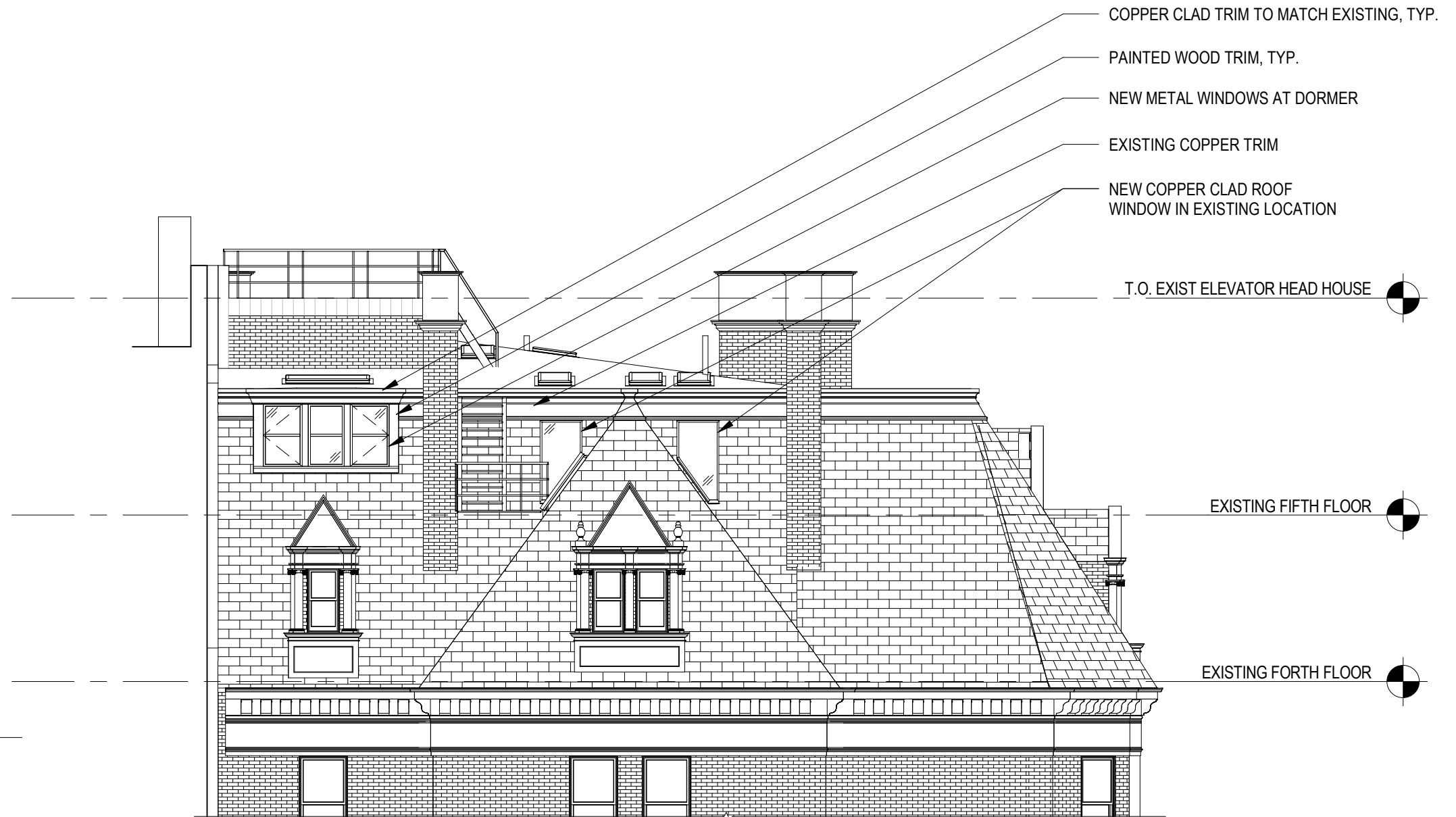

- COPPER CLAD TRIM TO MATCH EXISTING, TYP.
- PAINTED WOOD TRIM, TYP.
- NEW METAL WINDOWS AT DORMER
- EXISTING COPPER TRIM
- NEW COPPER CLAD ROOF WINDOW IN EXISTING LOCATION

T.O. EXIST ELEVATOR HEAD HOUSE

EXISTING FIFTH FLOOR

EXISTING FORTH FLOOR



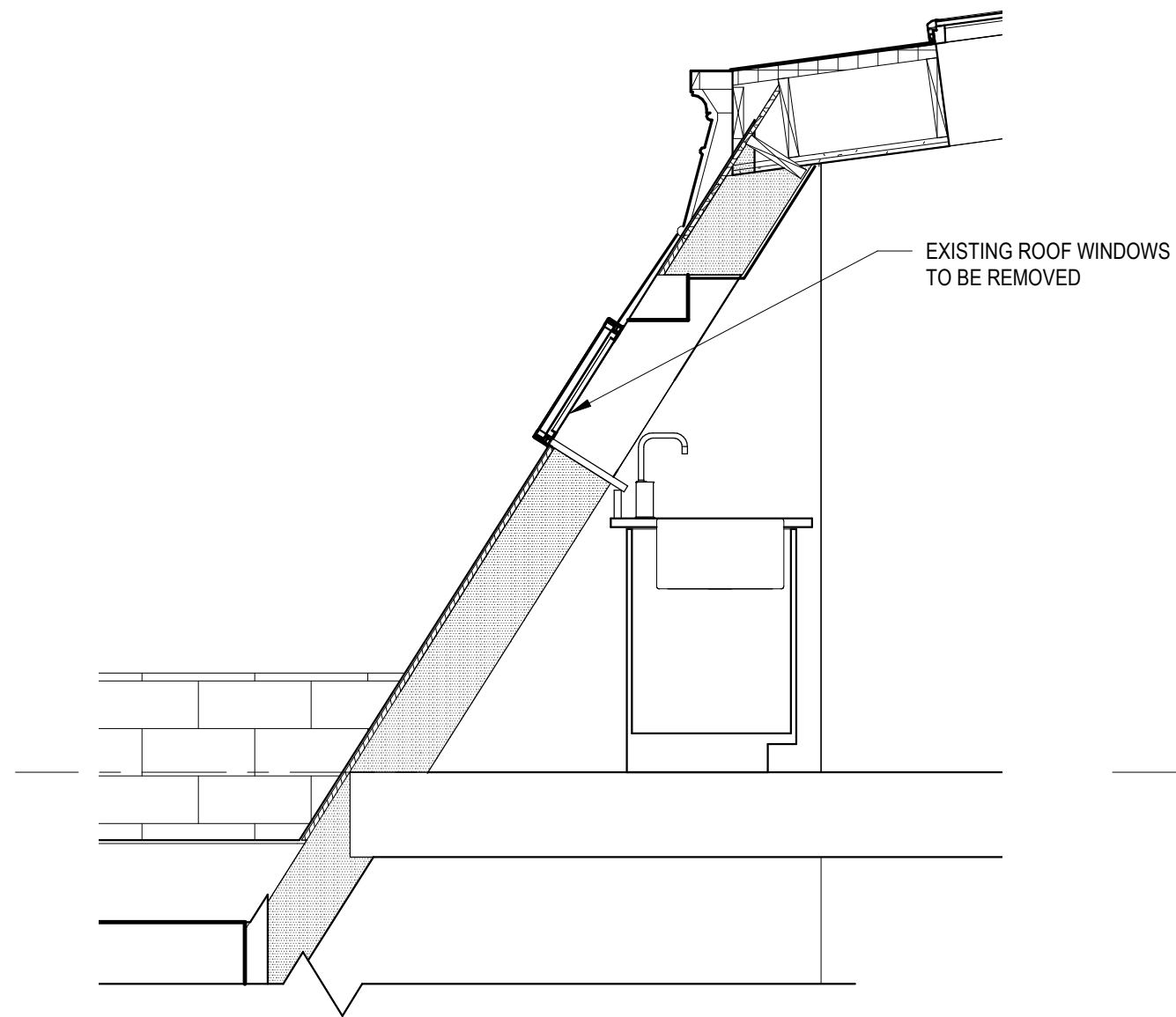

2 EXISTING KITCHEN DORMER
SCALE: 1/2" = 1'-0"

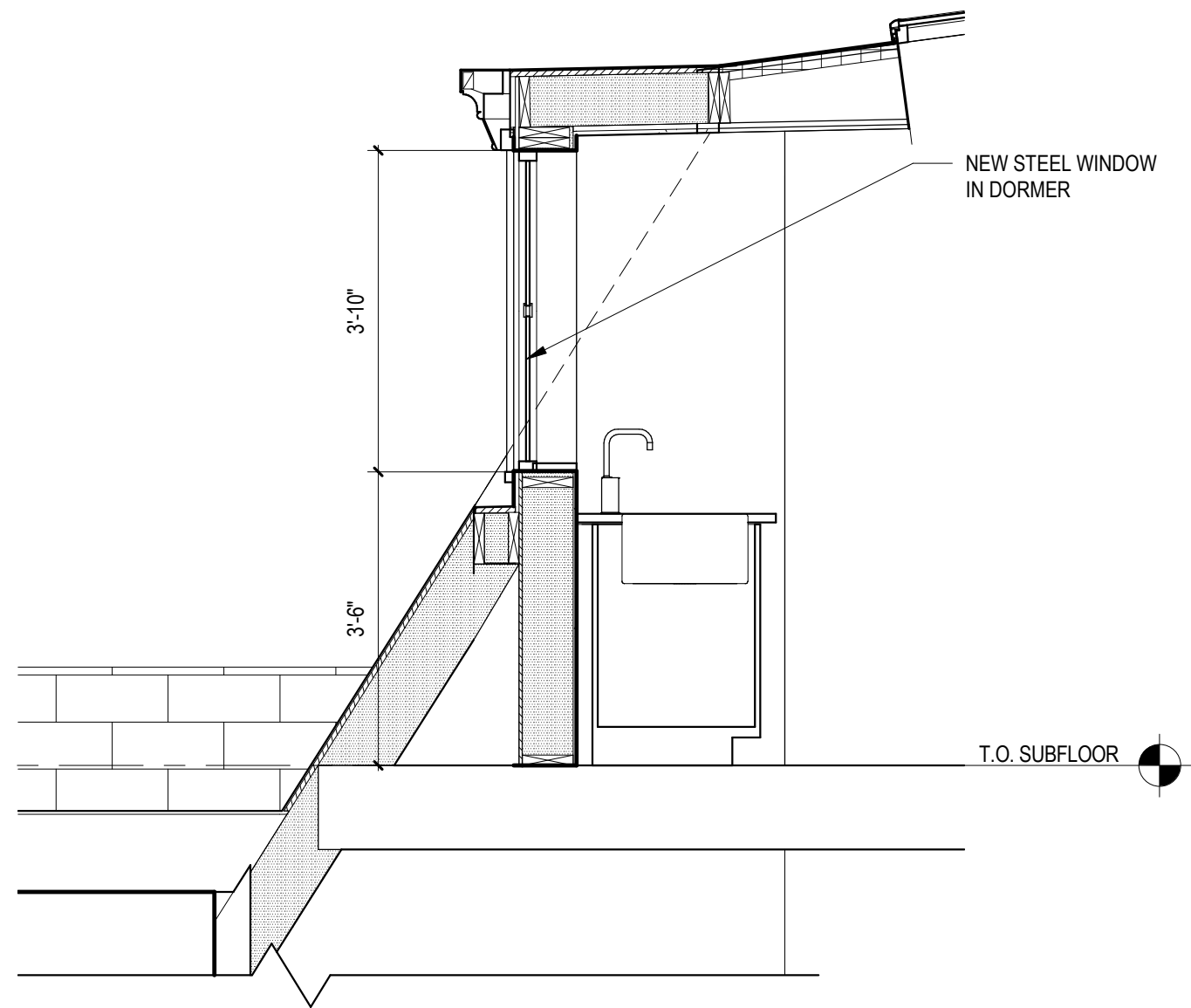

1 PROPOSED NEW DORMER
SCALE: 1/2" = 1'-0"

Corporate W20
Open Out Vents

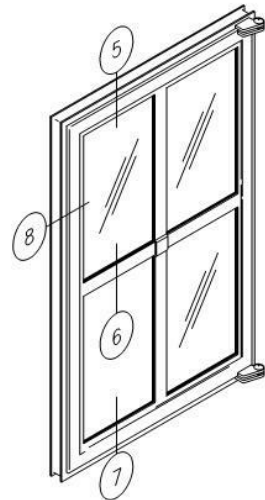

Side Hung
(Equal Leg Shown)
Top Hung similar

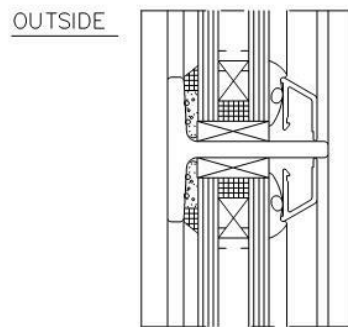
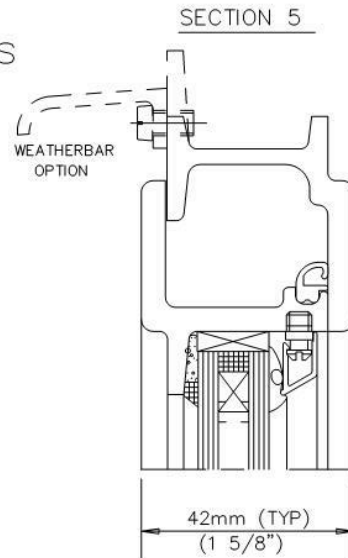

SECTION 6
OPTIONAL
GLAZING BAR

SECTION 8

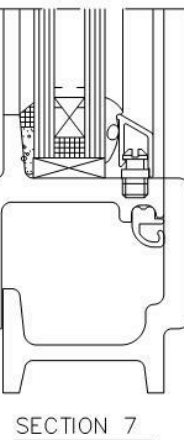
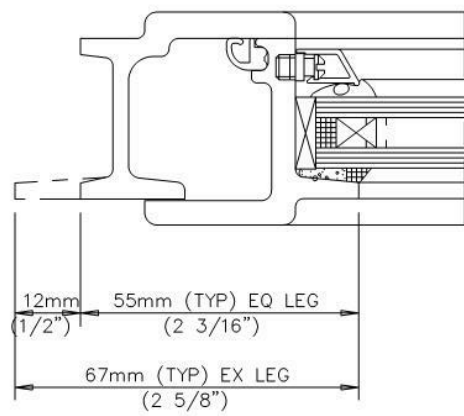

STEEL
B2

© CRITTALL WINDOWS LTD. 2005

DORMER WINDOW AT KITCHEN

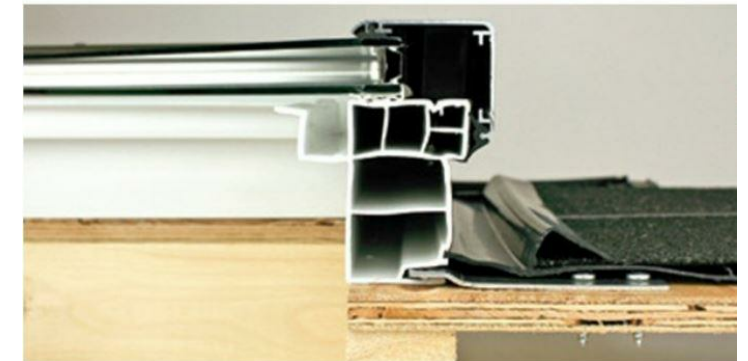

COPPER CLAD ROOF WINDOW



EXISTING FROM MALL @ COMM
AVE WEST

PROPOSED FROM MALL @
COMM AVE WEST

1

2

SCALE:

SCALE:



EXISTING FROM GLOUCESTER
@ ALLEY

1

SCALE:



PROPOSED FROM
GLOUCESTER @ALLEY

2

SCALE:



1 EXISTING FROM PUBLIC ALLEY
SCALE:

2 PROPOSED FROM PUBLIC ALLEY
SCALE: