



APPLICATION
CERTIFICATE of APPROPRIATENESS-or-
DESIGN APPROVAL-or-EXEMPTION

Deliver or mail to:
Environment Department
Boston City Hall, Room 709
Boston, MA 02201

For Office Use Only

APPLICATION # _____
RECEIVED _____
FEE _____
HEARING DATE _____

DO NOT RETURN THIS FORM BY FAX OR EMAIL

DO NOT STAMP THIS BOX

I. PROPERTY ADDRESS 700 TREMONT ST.
NAME of BUSINESS/PROPERTY PUBLIC UTILITY RIGHT OF WAY

The names, telephone numbers, postal and e-mail addresses requested below will be used for all subsequent communications relating to this application. Environment Department personnel cannot be responsible for illegible, incomplete or inaccurate contact information provided by applicants.

II. APPLICANT EXTENET SYSTEMS, INC.
CONTACT NAME KEENAN BRINN RELATIONSHIP TO PROPERTY LICENSEE
MAILING ADDRESS 31 CHESTERFIELD RD., MILTON, MA ZIP 02186
PHONE 617-680-5464 EMAIL KBRINN@NBCLLC.COM
PROPERTY OWNER CITY OF BOSTON CONTACT NAME JOHN YETMAN
MAILING ADDRESS 400 FRONTAGE RD., BOSTON, MA ZIP _____
PHONE _____ EMAIL JOHN.YETMAN@BOSTON.GOV
ARCHITECT N/A CONTACT NAME _____
MAILING ADDRESS _____ ZIP _____
PHONE _____ EMAIL _____
CONTRACTOR NB+C CONTACT NAME KEENAN BRINN
MAILING ADDRESS 100 APOLLO DR., CHELMSFORD, MA ZIP 02184
PHONE 617-680-5464 EMAIL KBRINN@NBCLLC.COM

III. DESCRIPTION OF PROPOSED WORK

A BRIEF OUTLINE OF THE PROPOSED WORK MUST BE PROVIDED IN THE SPACE BELOW, OR THE APPLICATION WILL NOT BE ACCEPTED. This description MUST include ALL proposed work, as the basis for the official notice and subsequent decision. Additional pages may be attached, if necessary, to provide more details.

THE APPLICANT, EXTENET SYSTEMS, INC., IS PROPOSING A SINGLE SMALL CELL INSTALLATION ON A LIGHT POLE AT THE ABOVE NOTED ADDRESS.

THIS WORK WILL INVOLVE THE ATTACHMENT OF A SINGLE ANTENNA AND AUXILIARY RADIO EQUIPMENT TO AN EXISTING POLE LOCATION. THE WORK ALSO INCLUDES NEW WIRING, ELECTRIC METER SET, GROUNDING, EXCAVATION, AND FIBER DELIVERY.

REQUIRED DOCUMENTATION: Please include all required documentation with this application; review instructions carefully for details.

ESTIMATED COST OF PROPOSED WORK: \$10,050

IV. DULY AUTHORIZED SIGNATURES (both required – UNSIGNED/PARTIALLY SIGNED FORMS ARE INCOMPLETE)

I, the undersigned, confirm that the facts set forth above in this application and accompanying documentation are a true statement made under penalty of perjury. I understand that misrepresenting owner consent/signatory authority and/or relevant facts in this application shall invalidate any Certificate of Appropriateness or Design Approval and, therefore, approval for permits. The Design Review Application is limited to the aforementioned work. I understand that any additional exterior work done under my ownership must be submitted by application and approved by the appropriate commission. Any unauthorized work will be required to be removed.

APPLICANT Keenan Brinn OWNER* John Yetman
PRINT KEENAN BRINN PRINT John Yetman
*(The Chair must sign for condominium.)

Environment Dept personnel are not responsible for verifying the authority of individuals' signatures.

THIS APPLICATION IS NOT COMPLETE WITHOUT SIGNATURES, FEES AND REQUIRED DOCUMENTATION. The checklist below is for reference only: Please refer to the detailed application instructions for deadlines, fee schedule and required documentation specific to your proposal.

- COMPLETED APPLICATION FORM
- APPLICATION FEE (Check or money order made payable to City of Boston; see fee schedule in Instructions)
- DESCRIPTION OF WORK (A brief description must be included on the front page; additional pages of detailed information may be attached. **Applications that only note "see attached" will not be accepted.**)
- PHOTOS OF EXISTING CONDITIONS - SEE LAST PAGE OF PLANS
- DRAWINGS AND SPECIFICATIONS AS REQUIRED (See "documentation requirements" in instructions)

Applicants scheduled to present at a public hearing are requested to submit an electronic version of the presentation one week prior to the hearing date.

Drop off or send completed application with all necessary attachments to
City of Boston Environment Department, Room 709, Boston City Hall, Boston MA 02201.
For more information, visit boston.gov/landmarks or call 617-635-3850.

PROJECT DESCRIPTION:

THESE PLANS REPRESENT A PORTION OF A PROPOSED SMALL CELL BUILD INVOLVING THE INSTALLMENT OF AN ANTENNA AND RADIO EQUIPMENT ON AN EXISTING WOODEN UTILITY OR REPLACEMENT METAL STREETLIGHT POLES.

**EXTENET SYSTEMS
700 TREMONT ST
BOSTON, MA 02118
(SOUTHEAST SIDE OF TREMONT ST)**

**CRAN_RCTB_00011_01
NE-MA-BOSTD3M1-11001**

PROJECT INFORMATION

INDEX:

1	COVER PAGE
2	SIDE PROFILE
3	REAR PROFILE
4	DETAILS - ANTENNA AND RADIOS
5	DETAILS - RADIO SHROUD
6	DETAILS - CONCRETE FOUNDATION
7	EXISTING PHOTO / WIRING DIAGRAM

POLE OWNER: CITY OF BOSTON

CONTACT: RICK ANGELINI
3030 WARRENVILLE RD
SUITE 340
LISLE, IL 60532
NOC: (866) 892-5327

LOCATION: BOSTON, MA
SUFFOLK COUNTY

NOTES:

PREPARED FOR:



PREPARED BY:



**NODE
RCTB-11_01
COVER PAGE**

REVISIONS		
REV	DESCRIPTION	DATE

DRAFTER: MAC
SCALE: AS SHOWN
ISSUE DATE: 03/27/18
INDEX NAME: RCTB-11_01
SHEET #: 1 OF 7

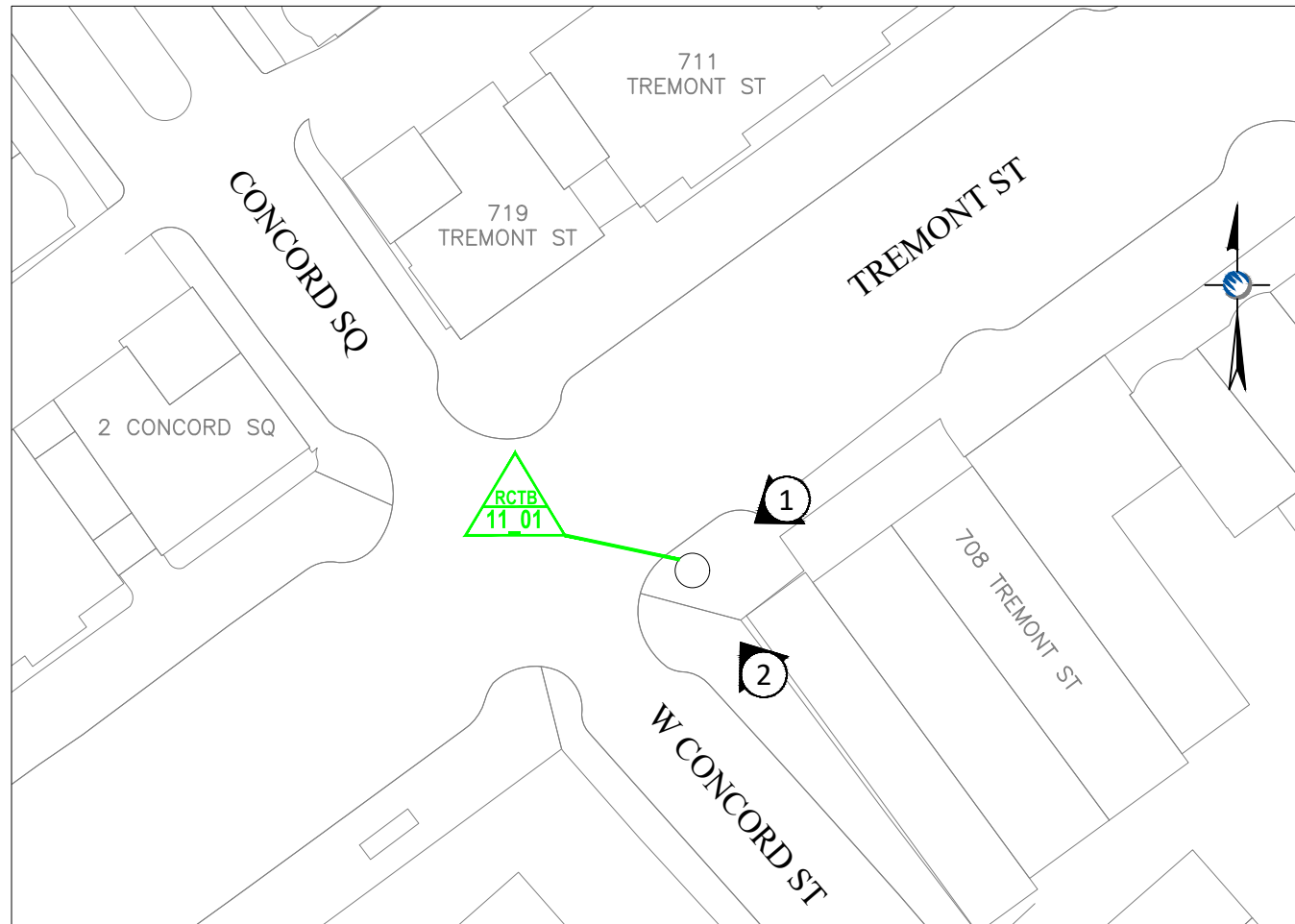

LOCATION MAP

LATITUDE: 42.340518° LONGITUDE: -71.077883°
ELEVATION: 9.84' AGL
SCALE: 1" = 50'

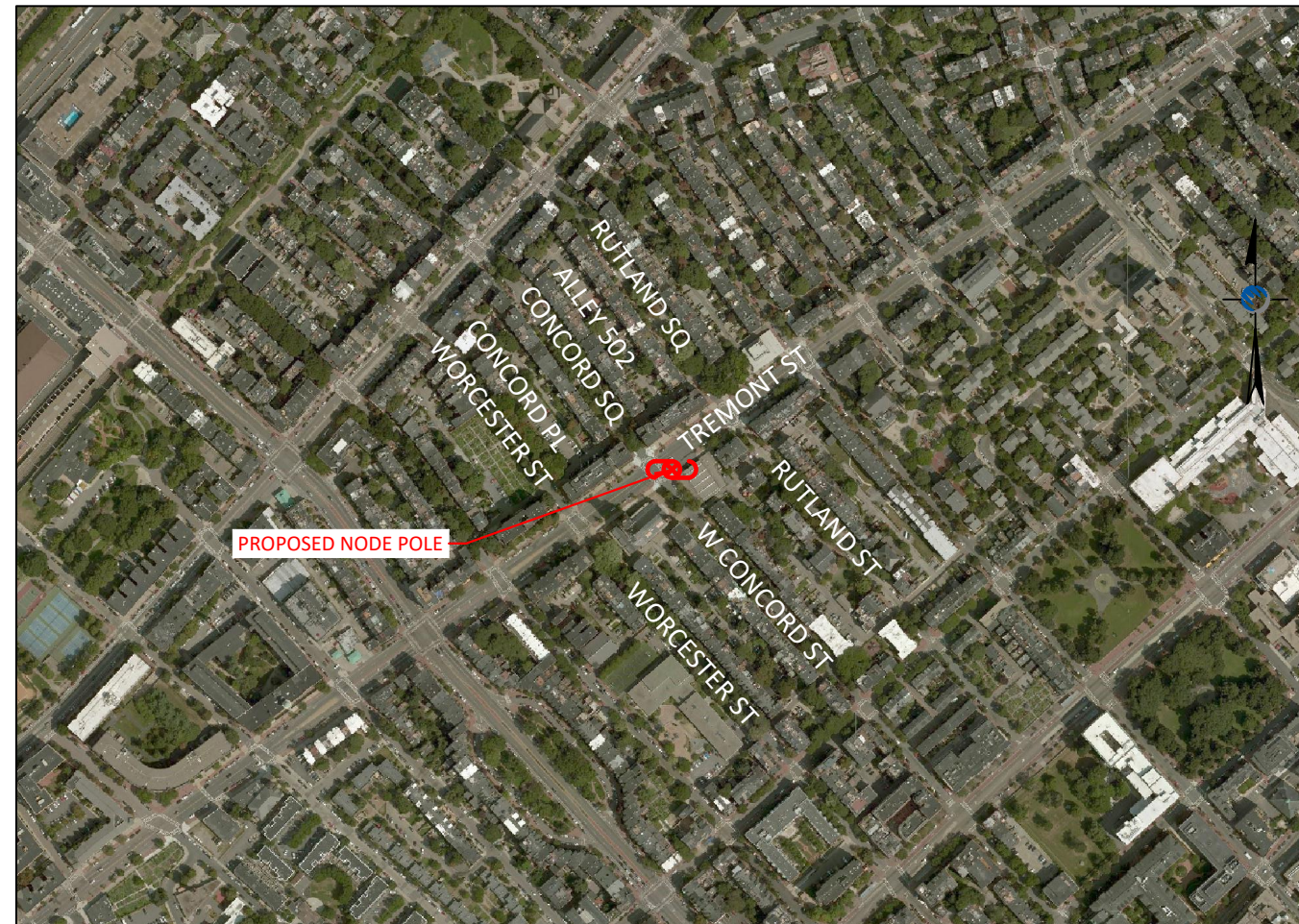

LOCUS MAP

PROJECT LOCATION - NODE RCTB-11_01
SCALE: 1" = 500'

FOR PERMITTING ONLY

DRAWINGS NOTES:

NOTE 1:
RELOCATE EXISTING STREET SIGN FROM 14' TO 11'
RELOCATE EXISTING STREET SIGN FROM 13'-3" TO 10'-3"
TO ACCOMMODATE NEW EQUIPMENT

NOTE 2:
PROPOSED EQUIPMENT TO BE PAINTED
TO BLEND WITH POLE

NOTE 3:
FCC MANDATED SIGNAGE TO BE ATTACHED TO POLE

NODE RCTB-11_01 700 TREMONT ST, BOSTON, MA SIDE PROFILE

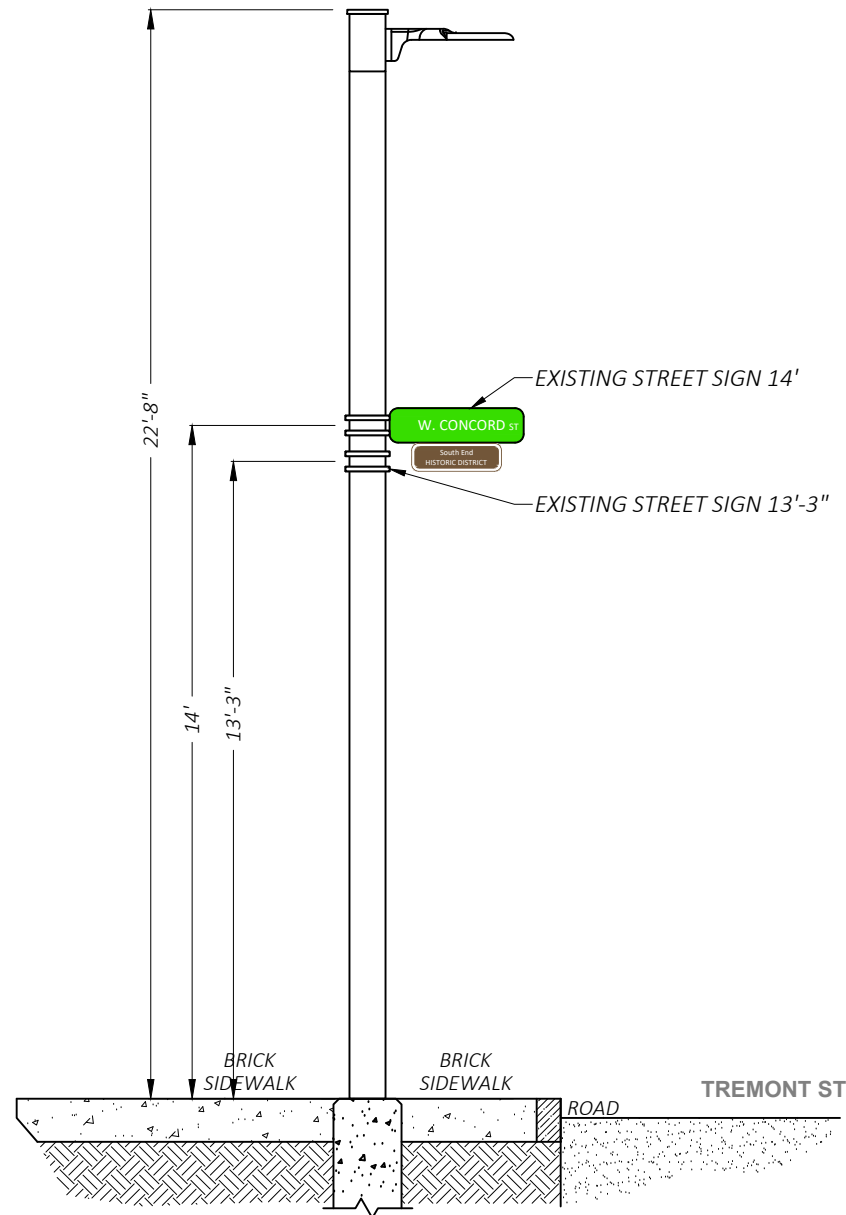

1 EXISTING PROFILE - SIDE VIEW
LOOKING SOUTHWEST ALONG TREMONT ST

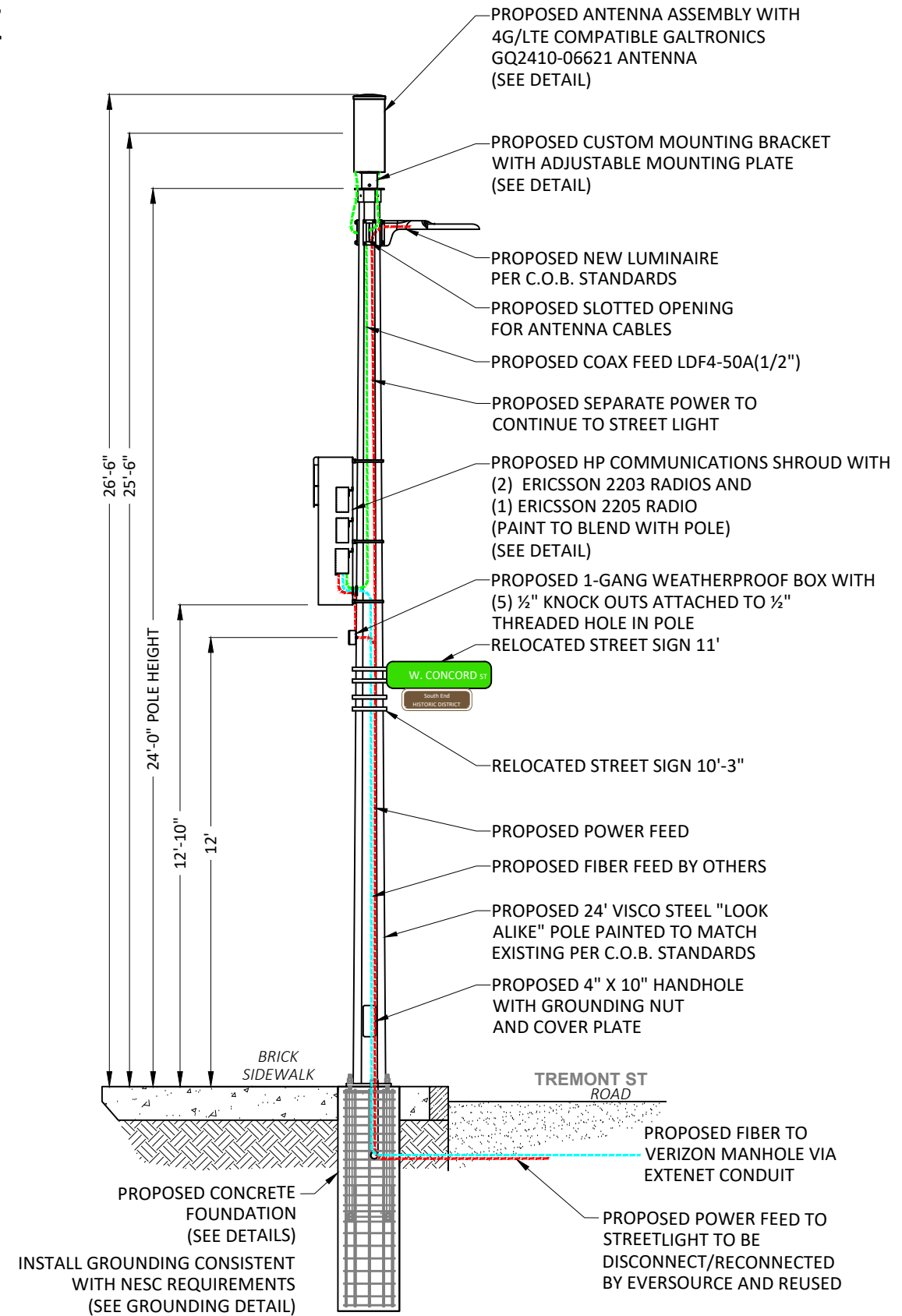
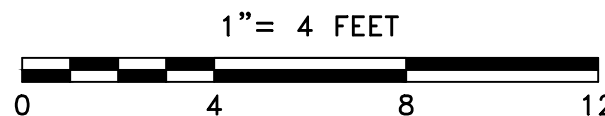

1 PROPOSED PROFILE - SIDE VIEW
LOOKING SOUTHWEST ALONG TREMONT ST

LOCATION:
BOSTON, MA
SUFFOLK COUNTY

NOTES:

PREPARED FOR:



PREPARED BY:

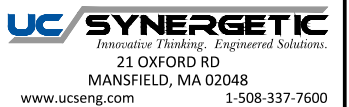

NODE
RCTB-11_01
SIDE PROFILE

REVISIONS		
REV	DESCRIPTION	DATE

DRAFTER: MAC
SCALE: SEE SCALE BAR
ISSUE DATE: 03/27/18
INDEX NAME: RCTB-11_01
SHEET #: 2 OF 7

N:\Engineering\Extenet Systems\NE-MA-BOSTON\1-ATT\NPP\AUTOCAD\NPP\NODE CRAN_RCTB_00011_01.dwg 3/28/18

DRAWINGS NOTES:

NOTE 1:
RELOCATE EXISTING STREET SIGN FROM 14' TO 11'
RELOCATE EXISTING STREET SIGN FROM 13'-3" TO 10'-3"
TO ACCOMMODATE NEW EQUIPMENT

NOTE 2:
PROPOSED EQUIPMENT TO BE PAINTED
TO BLEND WITH POLE

NOTE 3:
FCC MANDATED SIGNAGE TO BE ATTACHED TO POLE

NODE RCTB-11_01 700 TREMONT ST, BOSTON, MA REAR PROFILE

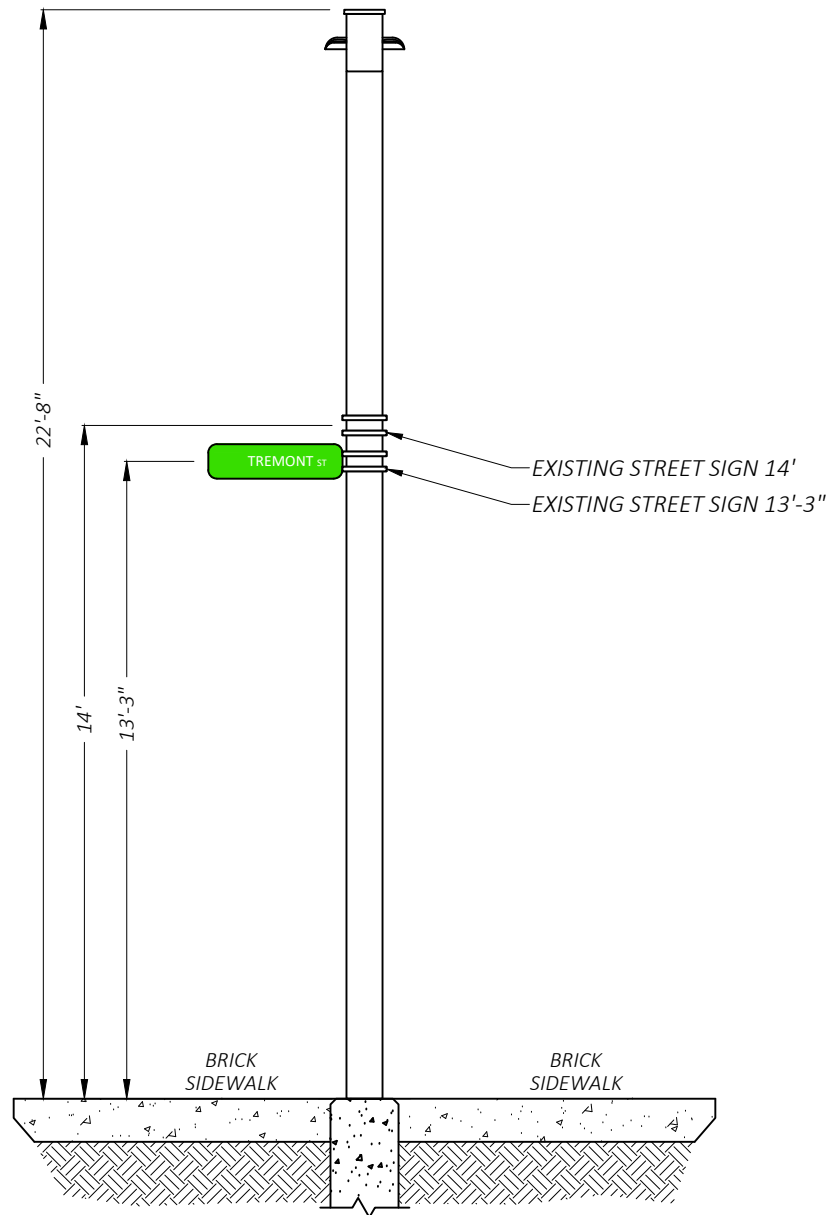

② EXISTING PROFILE - REAR VIEW
LOOKING NORTHWEST TOWARDS TREMONT ST

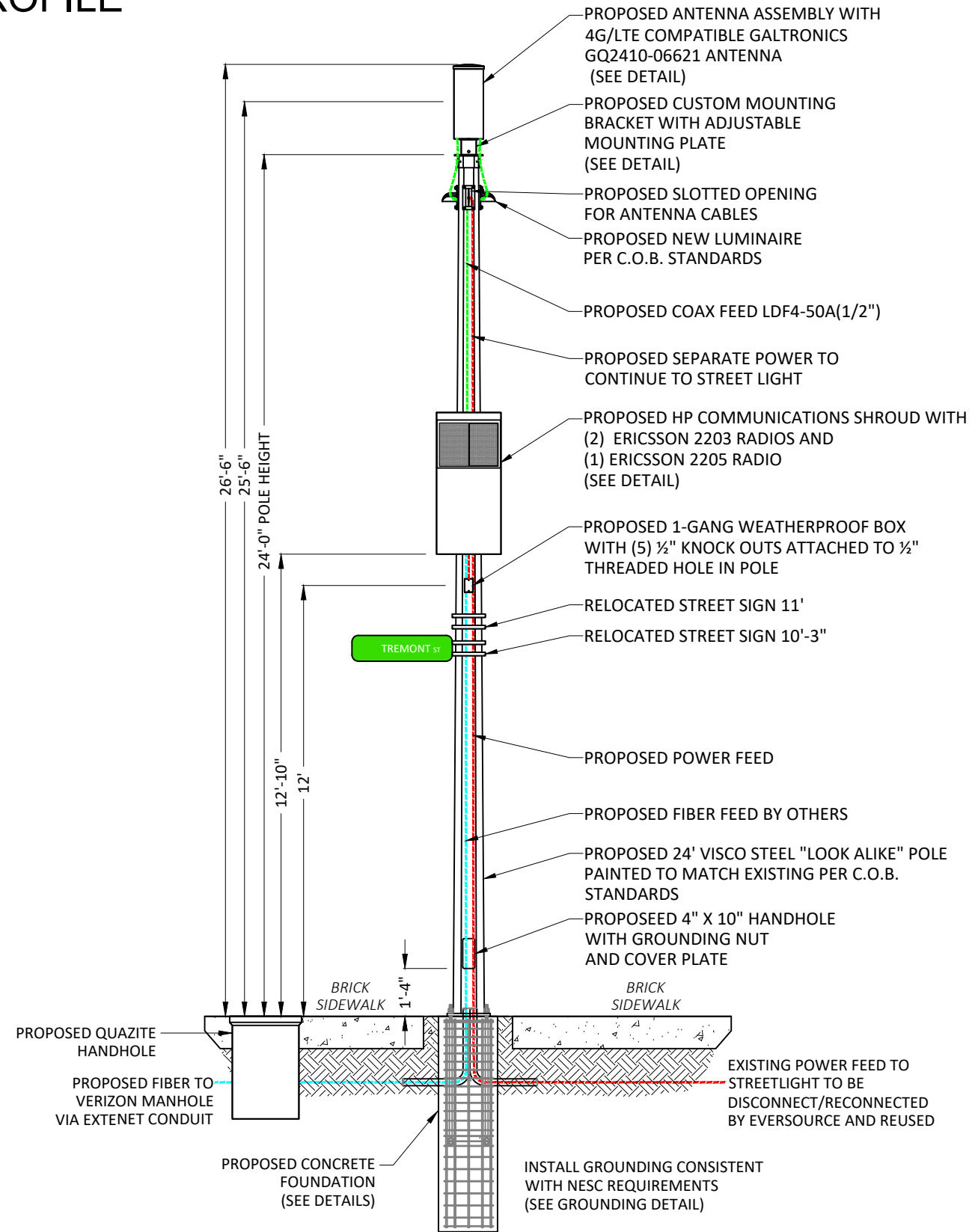
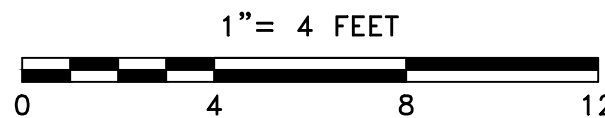

② PROPOSED PROFILE - REAR VIEW
LOOKING NORTHWEST TOWARDS TREMONT ST

LOCATION:
BOSTON, MA
SUFFOLK COUNTY

NOTES:

PREPARED FOR:



PREPARED BY:

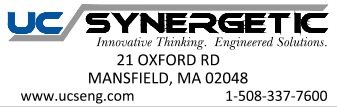

NODE
RCTB-11_01
REAR PROFILE

REVISIONS		
REV	DESCRIPTION	DATE

DRAFTER: MAC
SCALE: SEE SCALE BAR
ISSUE DATE: 03/27/18
INDEX NAME: RCTB-11_01
SHEET #: 3 OF 7

N:\Engineering\Extenet Systems\NE-MA-BOSTON\1-ATT\NPP\AUTOCAD\NPP\NODE CRAN_RCTB_00011_01.dwg 3/28/18



24"x 10" Pseudo Omni 10-Port Canister Antenna [1695-2360, 3550-3700 and 5150-5925 MHz]

GQ2410-06621

Description:

- Pseudo Omni Canister Antenna for Outdoor DAS and Small Cells.
- 4x ports for AWS/PCS/WCS Band 1695-2360 MHz
- 4x ports for CBRS Band 3550-3700 MHz
- 2x ports for UNII Band 5150-5925 MHz*

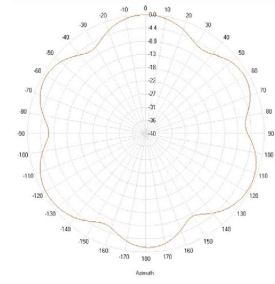

1695-2360, 3550-3700 and 5150-5925 MHz Pseudo Omni Canister Antenna

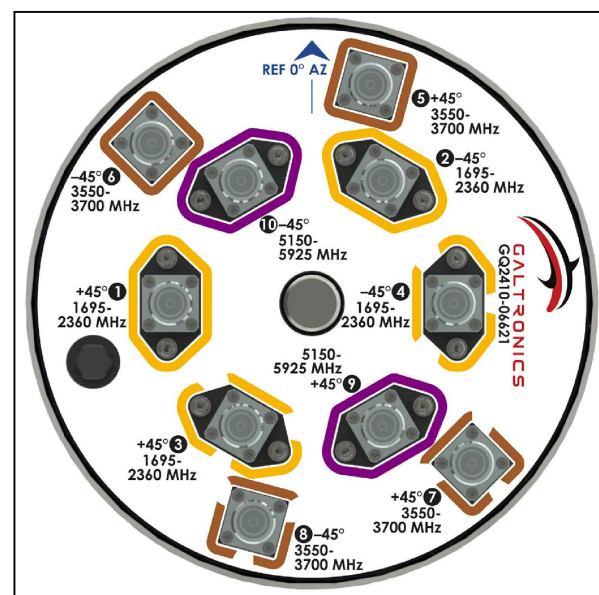
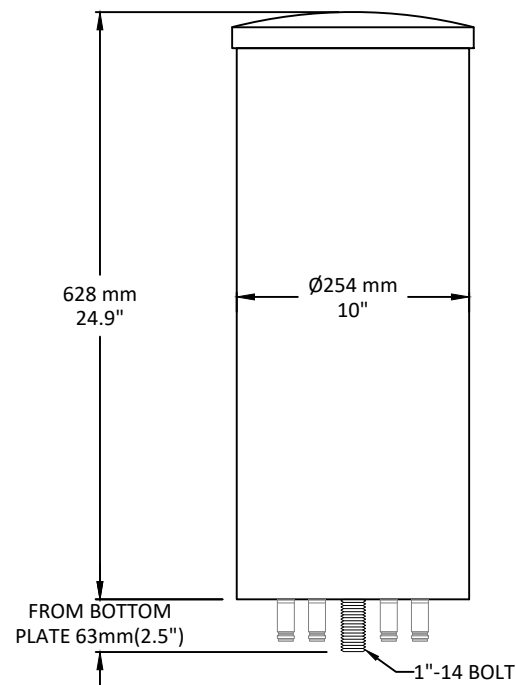

GALTRONICS GQ2410-06621 ANTENNA

SCALE: NTS

ERICSSON RADIO 2205 WITH COVER

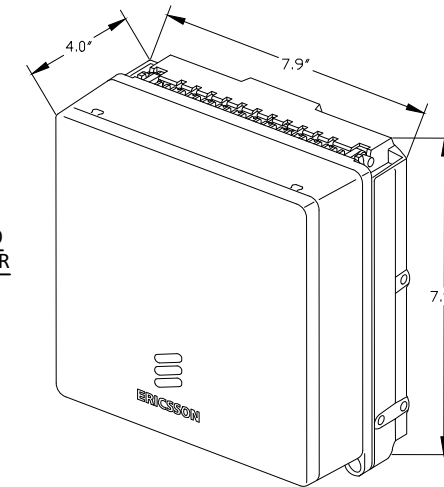

ERICSSON RADIO 2203 WITH COVER

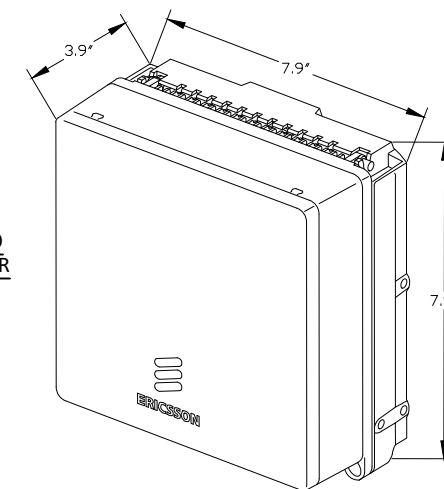

**ERICSSON 2203 & 2205 RADIOS WITH COVER
POLE MOUNT REMOTE UNIT**

SCALE: NTS

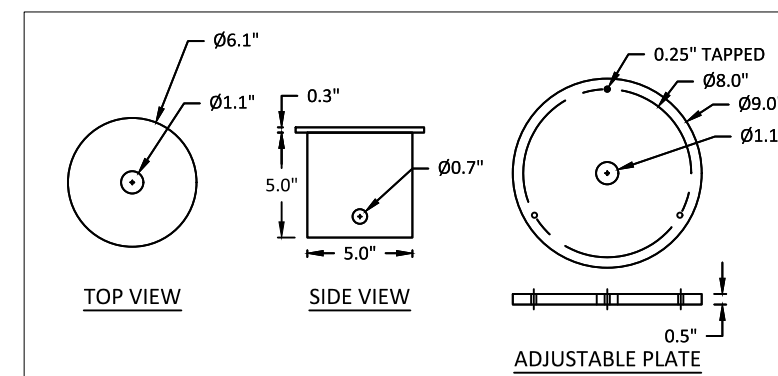

CUSTOM ANTENNA MOUNTING BRACKET

SCALE: NTS

LOCATION:
BOSTON, MA
SUFFOLK COUNTY

NOTES:

PREPARED FOR:



PREPARED BY:



NODE
RCTB-11_01
DETAILS - ANTENNA & RADIOS

REVISIONS		
REV	DESCRIPTION	DATE

DRAFTER: MAC
SCALE: NTS
ISSUE DATE: 03/27/18
INDEX NAME: RCTB-11_01
SHEET #: 4 OF 7

3/28/18 N:\Engineering\Extenet_Systems\NE-MA-BOST3M1-ATT\NPPS\AUTOCAD\NPPS\NODE CRAN_RCTB_00011_01.dwg

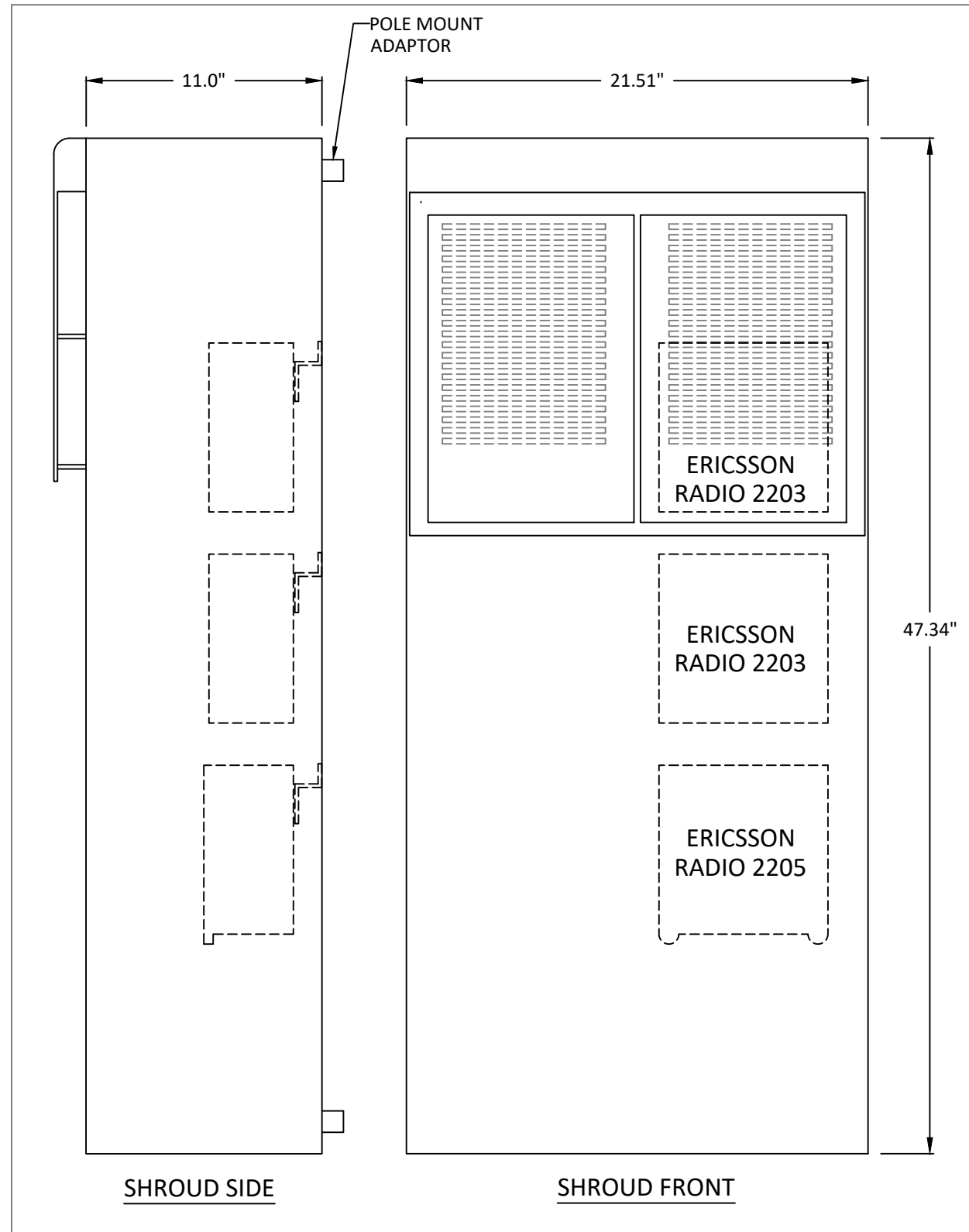

HP COMMUNICATIONS SHROUD
6.48 CUBIC FEET
 SCALE: NTS

LOCATION: BOSTON, MA
 SUFFOLK COUNTY

NOTES:

PREPARED FOR:



PREPARED BY:

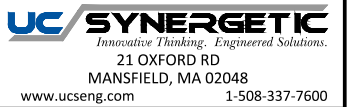

NODE
 RCTB-11_01
 DETAILS - RADIO SHROUD

REVISIONS		
REV	DESCRIPTION	DATE

DRAFTER: MAC
 SCALE: NTS
 ISSUE DATE: 03/27/18
 INDEX NAME: RCTB-11_01
 SHEET #: 5 OF 7

GENERAL NOTES

1. CONTRACTOR IS RESPONSIBLE FOR CHECKING AREA FOR UNDERGROUND FACILITIES PRIOR TO EXCAVATING ANY MATERIALS.
2. CONTRACTOR SHALL INSPECT AND REMOVE ALL DEBRIS FROM BOTTOM OF EXCAVATION.
3. CONTRACTOR SHALL VERIFY ANCHOR BOLT LAYOUT PRIOR TO, AND IMMEDIATELY AFTER PLACING CONCRETE. ANCHOR BOLT LAYOUT IS CRITICAL FOR MONOPOLE INSTALLATION.
4. CONTRACTOR SHALL USE AND PROVIDE DEFORMED REINFORCING BARS CONFORMING TO ASTM A615 GR. 60 (60,000 PSI MIN. YIELD). CONTRACTOR SHALL USE STEEL WIRE TO HOLD REINFORCING BARS TOGETHER. IF WELDING REBAR IS PREFERRED, SUBSTITUTE USING A706 GR. 60 DEFORMED BARS.
5. CONTRACTOR SHALL USE AND PROVIDE CONCRETE WITH A MINIMUM COMPRESSIVE STRENGTH OF 4,000 PSI. CONCRETE SHALL USE 1" MAXIMUM STONE AGGREGATE, MIX DESIGN: 6 1/2 SACKS OF CEMENT MINIMUM PER CUBIC YARD, 5" MINIMUM AND 7" MAXIMUM CONCRETE SLUMP.
6. CONCRETE SHALL BE CONSOLIDATED USING VIBRATORY METHODS THROUGHOUT DEPTH OF FOUNDATION. VIBRATING LOWER DEPTHS MAY BE ACCOMPLISHED BY TOUCHING REBAR CAGE WITH VIBRATOR.
7. CONTRACTOR SHOULD ANTICIPATE THE USE OF A FULL-LENGTH TEMPORARY CASING TO STABILIZE THE EXCAVATION. THE CASING SHALL BE WITHDRAWN DURING THE PLACEMENT OF CONCRETE IN THE EXCAVATED HOLE. CONCRETE SHALL BE PLACED USING CONVENTIONAL METHODS TO MINIMIZE SEGREGATION OF CONCRETE AND AGGREGATE. CONCRETE SHALL NOT FREE FALL MORE THAN 5 FT. CONCRETE MAY BE PLACED BELOW WATER USING TREMIE METHODS.
8. CONCRETE SHALL BE PLACED TO THE DEPTH INDICATED, AND THE ABOVE GRADE PORTION SHALL BE FORMED. THE REBAR CAGE, ANCHOR BOLTS, AND CONCRETE SHALL BE PLACED WITHIN 24 HOURS OF COMPLETING THE EXCAVATION. COLD JOINTS ARE NOT ALLOWED.
9. THE CONTRACTOR IS RESPONSIBLE FOR VERIFYING ADEQUATE CONCRETE COVERAGE OVER REINFORCING BARS TO MINIMIZE CORROSION POTENTIAL. UNLESS OTHERWISE NOTED, CONTRACTOR SHALL USE 3" CONCRETE COVER OVER REBAR. TOP OF FOOTING SHALL BE TROWELLED LEVEL AND SMOOTH.
10. DRILLED PIER FOUNDATION DESIGN PER 2009/2012 IBC, TABLE 1806.2, CLASS 4 MATERIAL.
11. TOTAL VOLUME OF CONCRETE REQUIRED FOR THIS FOUNDATION IS APPROXIMATELY 1.1 CU. YDS.

FACTORED BASE REACTIONS

MOMENT = 30.9 ft-kips
 SHEAR = 2.46 kips
 VERTICAL = 1.67 kips

SPECIAL INSPECTIONS

SPECIAL INSPECTION: THE FOLLOWING ELEMENTS OF CONSTRUCTION SHALL REQUIRE SPECIAL INSPECTION PER 2009/2012 IBC, SECTION 1704

ITEM	DESCRIPTION	INSPECTION BY	MATERIAL
1	PIER EXCAVATION LATERAL BEARING CAPACITY	SOILS ENGINEER	300 PSF/FT LATERAL
2	PIER CONSTRUCTION REINFORCING STEEL BAR SIZES AND INSTALLATION	SPECIAL INSPECTOR	ASTM A615 GR. 60
3	ANCHOR BOLTS BOLT SIZE AND LENGTHS INSTALLATION	SPECIAL INSPECTOR	ASTM F1554 GR. 55
4	CONCRETE TEST SPECIMENS PLACEMENT OF CONCRETE	SPECIAL INSPECTOR	f _c = 4,000 PSI TYPE II CEMENT

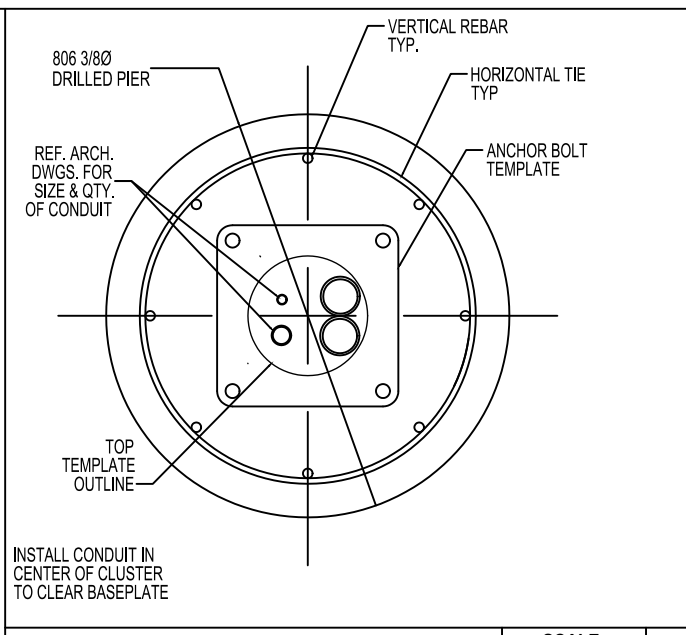

CONDUIT DETAIL @ PIER SECTION SCALE: NONE 1

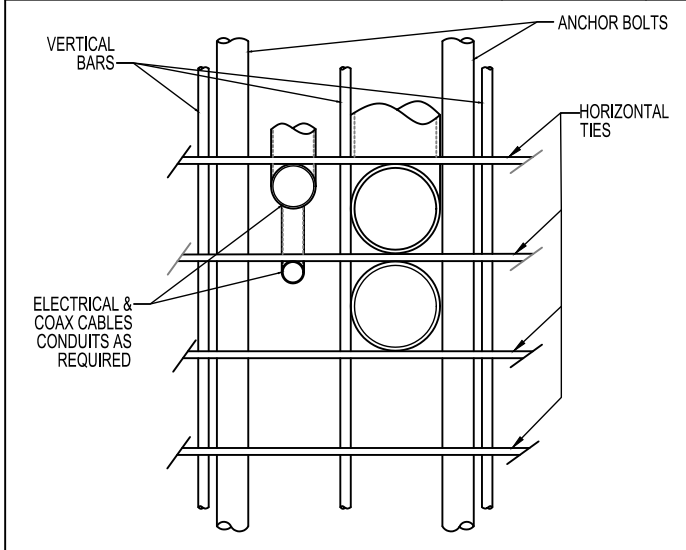

* ADJUST REBAR AS NEEDED TO ACCOMMODATE CONDUIT. SEE REINFORCEMENT SUMMARY FOR SIZE, QUANTITY AND LOCATION OF VERTICAL BARS AND HORIZONTAL TIES.

CONDUIT DETAIL SCALE: NONE 2

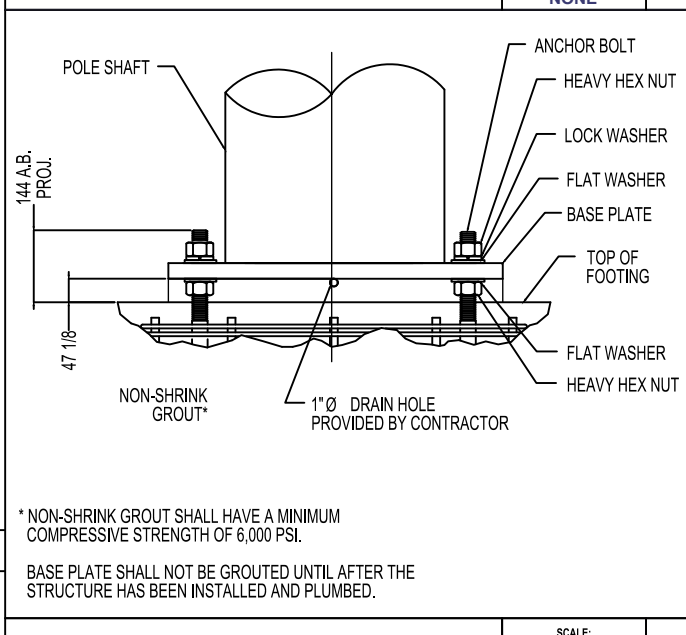

BASE GROUTING DETAIL SCALE: NONE 3

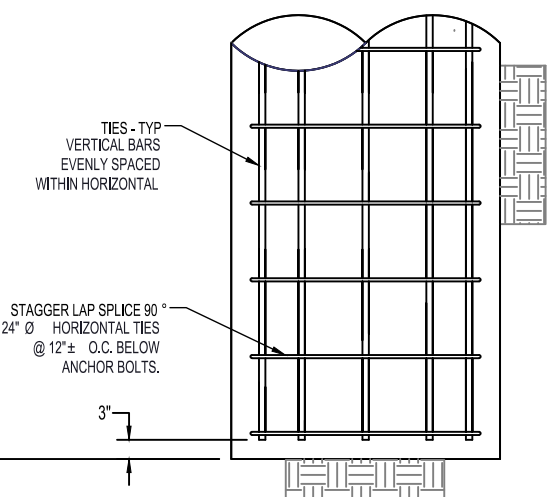
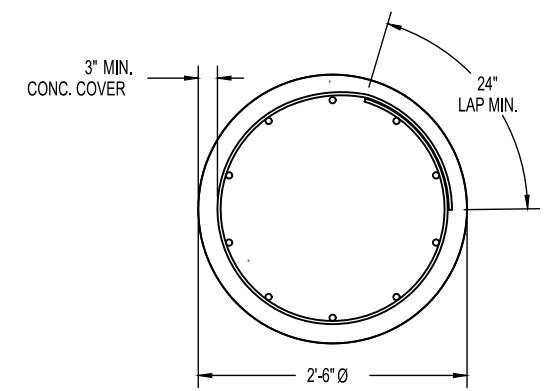
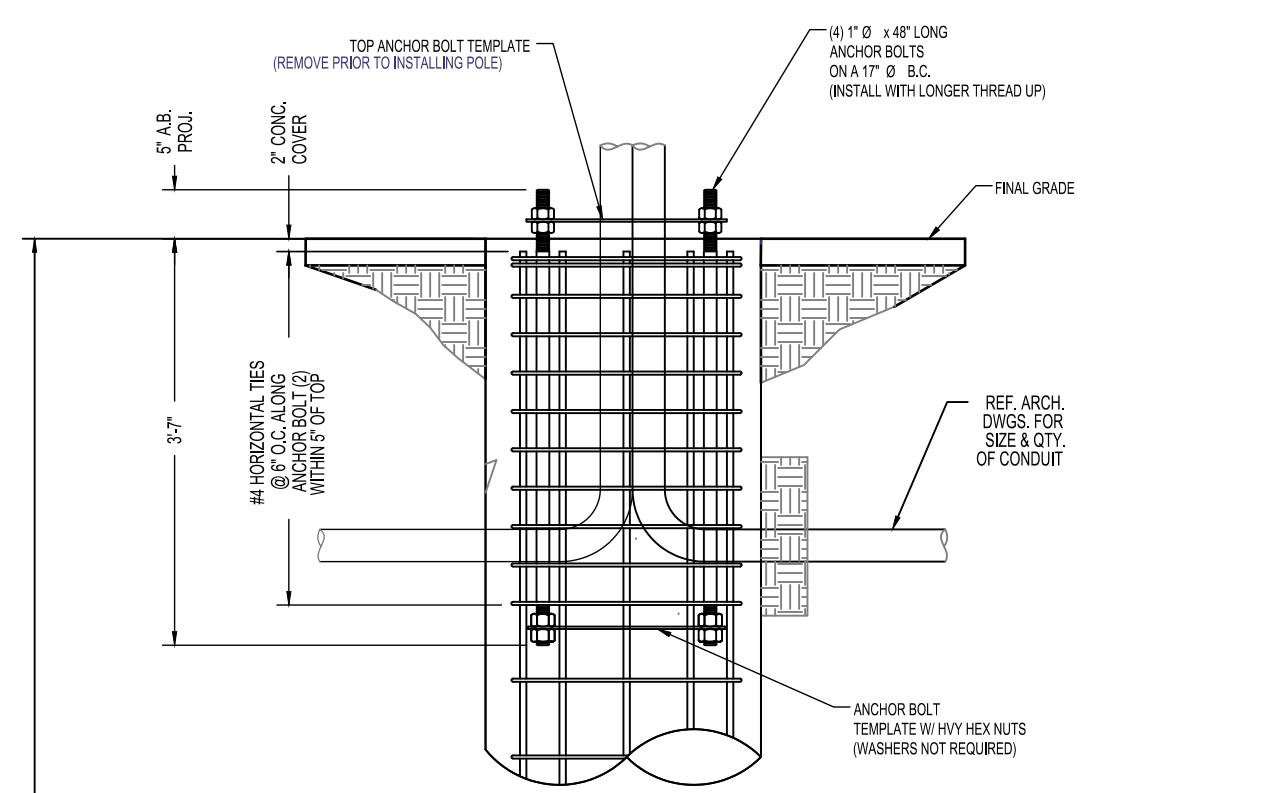

PIER FOUNDATION INSTALLATION

DESCRIPTION	QTY.	SIZE	LENGTH	WEIGHT	OVERLAP
VERTICAL BARS	8	#6	5'-6"	66 LBS.	N/A
HORIZONTAL TIES	10	#4	8'-4"	55 LBS.	2'-0"

LOCATION: BOSTON, MA
 SUFFOLK COUNTY

NOTES:

PREPARED FOR:
 YOUR NETWORK. EVERYWHERE.

PREPARED BY:
 Innovative Thinking. Engineered Solutions.
 21 OXFORD RD
 MANSFIELD, MA 02048
 www.ucseeng.com 1-508-337-7600

NODE
 RCTB-11_01
 DETAILS - CONCRETE FOUNDATION

REVISIONS		
REV	DESCRIPTION	DATE

DRAFTER: MAC
 SCALE: NTS
 ISSUE DATE: 03/27/18
 INDEX NAME: RCTB-11_01
 SHEET #: 6 OF 7



EXISTING POLE
SCALE: NTS

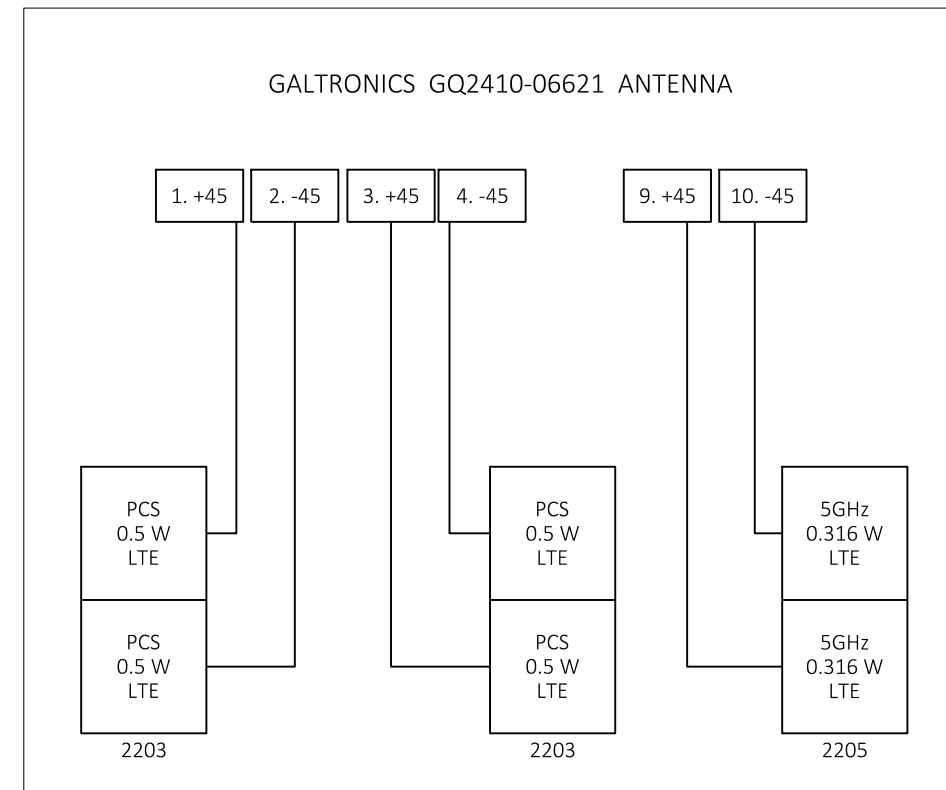

WIRING DIAGRAM
SCALE: NTS

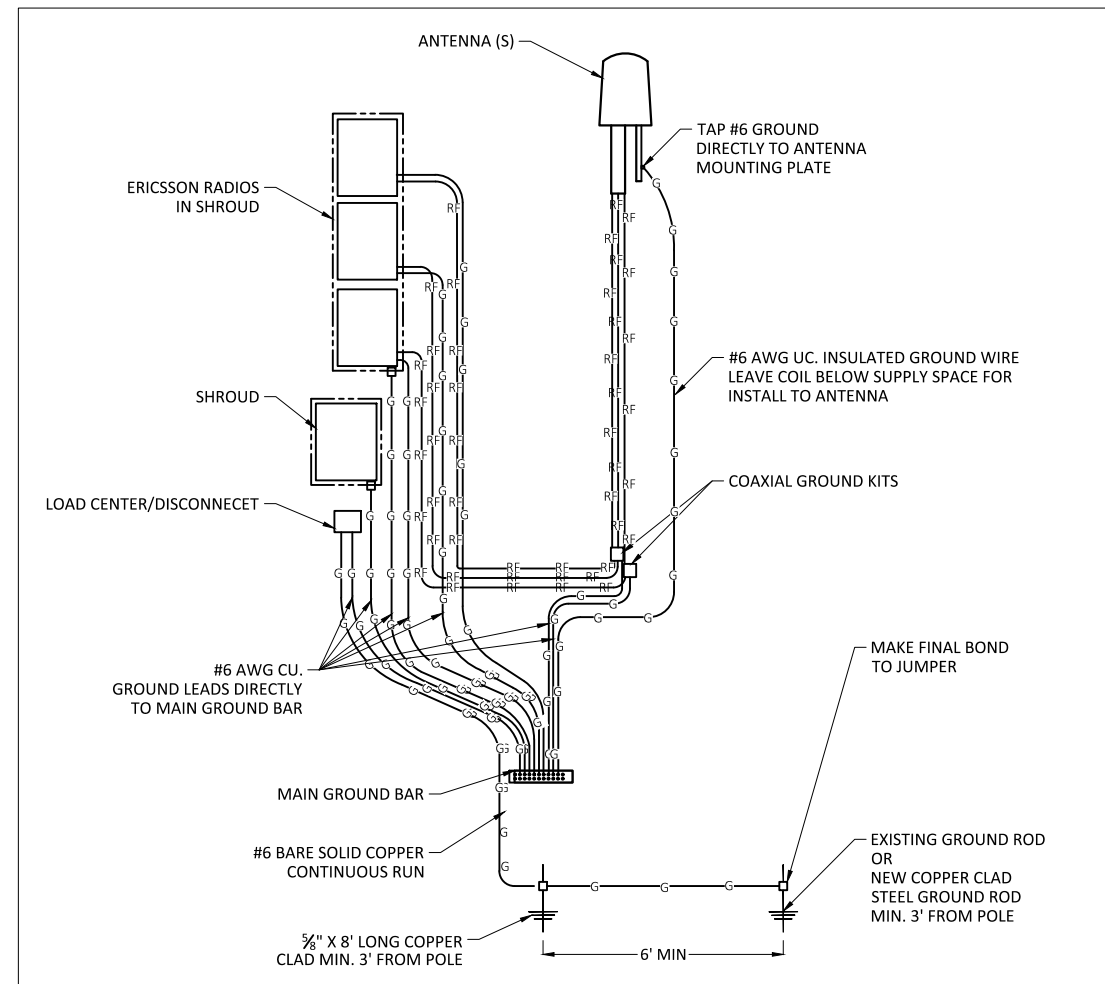

GROUNDING DIAGRAM
SCALE: NTS

LOCATION: BOSTON, MA
SUFFOLK COUNTY

NOTES:

PREPARED FOR:



PREPARED BY:



NODE
RCTB-11_01
EXISTING PHOTO/WIRING DIAGRAM

REVISIONS		
REV	DESCRIPTION	DATE

DRAFTER: MAC
SCALE: NTS
ISSUE DATE: 03/27/18
INDEX NAME: RCTB-11_01
SHEET #: 7 OF 7

N:\Engineering\Extenet Systems\NE-MA-BOSTON\1-ATT\NPP\AUTOCAD\NPP\NODE CRAN_RCTB_00011_01.dwg 3/28/18



EXTENET SYSTEMS DISTRIBUTED NETWORK OVERVIEW FOR BOSTON LANDMARKS COMMISSION

2018

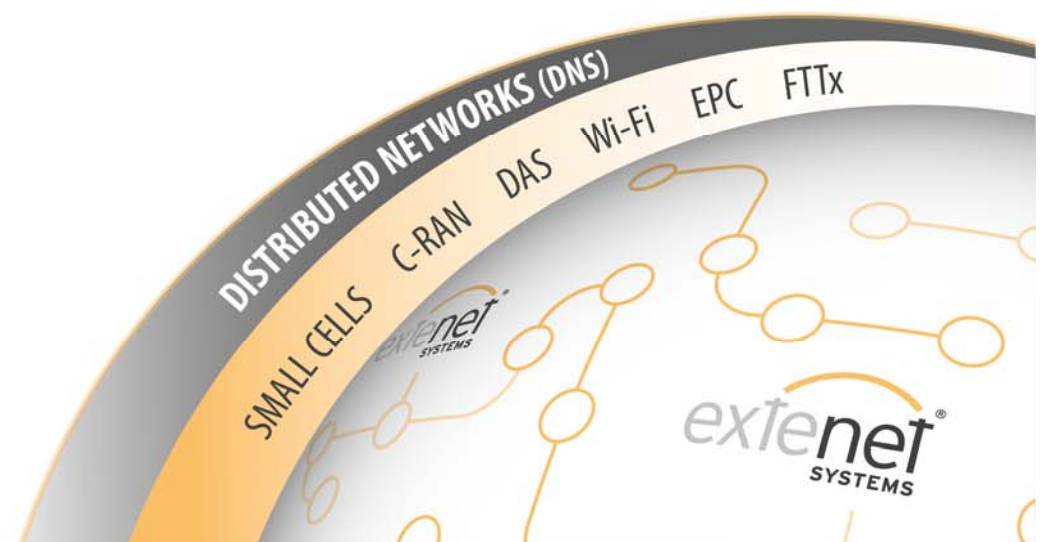

ABOUT EXTENET

Lisle, Ill.-based [ExteNet Systems, Inc.](http://www.extenetsystems.com) designs, builds, owns and operates distributed networks (DNS) for use by wireless carriers, broadband providers, IoT companies, property owners and communities across the United States. ExteNet deploys scalable communications infrastructure to enhance wireless and broadband services across both outdoor and indoor environments using fiber-based distributed antenna systems (DAS), remote radio heads (RRH), small cells, Wi-Fi, Virtualized Evolved Packet Core (vEPC) and other technologies. ExteNet's outdoor distributed networks are deployed in a variety of urban, suburban and rural environments. Indoor distributed networks are deployed in various property verticals including sports and entertainment venues, hotels and convention centers, commercial office space, healthcare facilities and transit systems. For more information, please visit www.extenetsystems.com

"ExteNet®" is a registered trademark of ExteNet Systems, Inc.

ABOUT EXTENET SYSTEMS

EXTENET IS A LEADING PROVIDER OF
CONVERGED COMMUNICATION INFRASTRUCTURE AND SERVICES
FOR ADVANCED NETWORK CONNECTIVITY

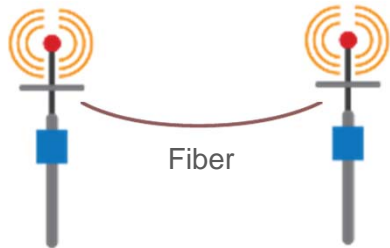

OUTDOOR NETWORKS

- | Suburban | Urban
- | Rural

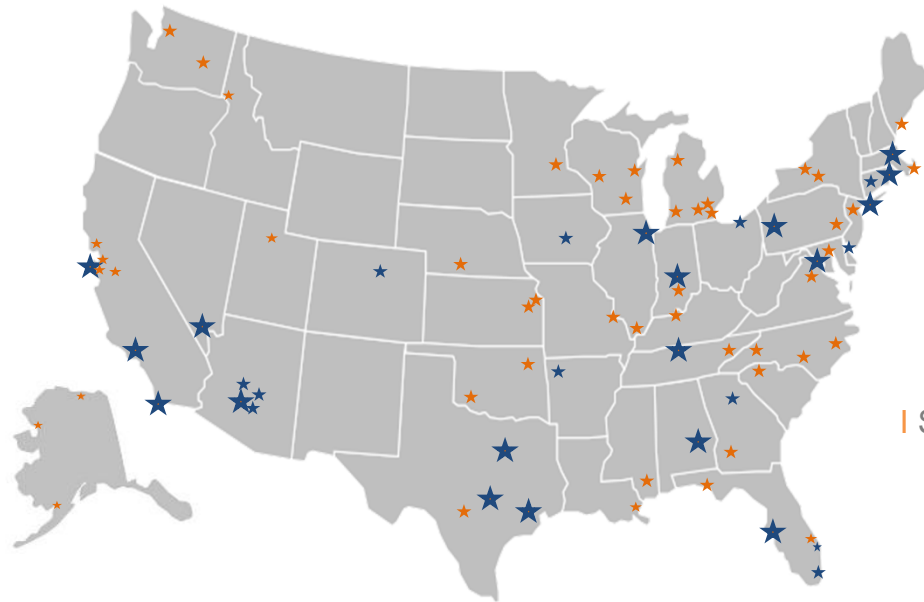

24 x 7

CARRIER CLASS NOC

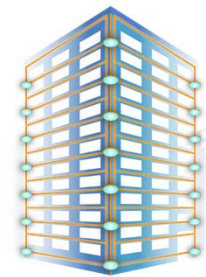

INDOOR NETWORKS

- | Sports & Entertainment | Class A
- | Hospitality | Healthcare

KEY EXTENET COMPANY FACTS

- | FOUNDED IN 2002 | LARGEST INDEPENDENT OWNER & OPERATOR OF DISTRIBUTED NETWORKS (DNS)
- | RE-CAPITALIZED FOR \$1.4 BILLION IN 2015 | PRIMARY CUSTOMERS INCLUDE CARRIERS & BUILDING OWNERS

ABOUT EXTENET – WHAT WE DO

ExteNet Systems designs, builds, owns, manages & operates Indoor & Outdoor Distributed Networks to help meet the growing demand for improved mobile & wireless broadband coverage and capacity in key strategic markets across North America. Distributed Networks bring wireless network elements such as low-powered wireless antennas and access points closer to the user to ensure ubiquitous and high-capacity wireless broadband connectivity.

Utilizing Distributed Antenna Systems (DAS), Remote Radio Heads (RRH), Small Cells, Wi-Fi and Distributed Core Soft-switching technologies, ExteNet enables Wireless Service Providers (WSPs), enterprises and venues to better serve their subscribers, customers, workers, residents, tenants and communities.

ExteNet owns and operates multi-carrier, often referred to as “neutral-host”, and multi-technology Distributed Networks to ensure multiple WSPs can provide their 3G and 4G LTE services in the most effective and efficient manner. ExteNet creates a scalable network design utilizing its high-bandwidth fiber network to ensure the Network Densification needs of the WSPs are met and can evolve over time as user demands dictate.

HIGHLIGHTED EXTENET DISTRIBUTED NETWORKS

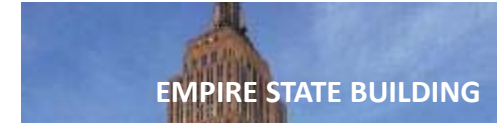
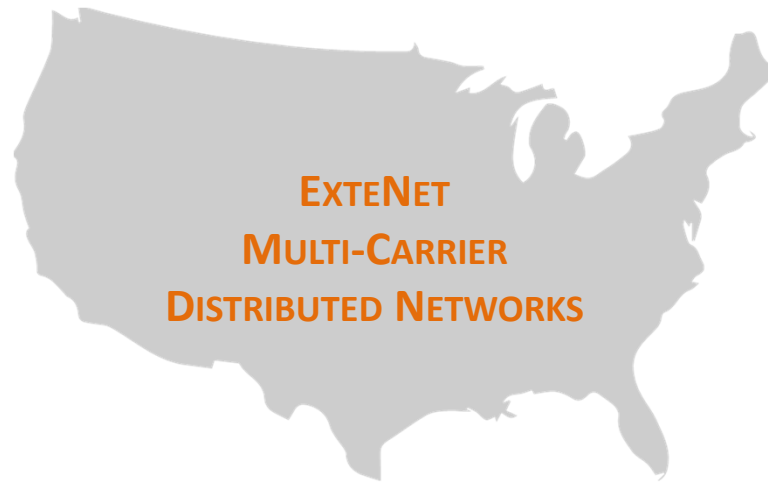

Urban : Suburban : Rural

Sports & Entertainment Venues :
Class A Commercial Buildings :
Hotels, Casinos & Convention Centers :
Healthcare Facilities :
Malls : Subways & Transit Systems

ENABLING ADVANCED COMMUNICATIONS VIA DISTRIBUTED NETWORKS (DNS)
ACROSS OUTDOOR AND INDOOR VERTICALS

ABOUT EXTENET – COMMUNITY FOCUSED

ExteNet enables advanced mobile connectivity for Wireless Service Providers (WSPs) and their customers, including residential users, businesses, government agencies and other organizations, via its Distributed Networks deployed across indoor and outdoor settings. Our distributed networks, which are generally designed and available to host multiple WSPs, improve service coverage and boost capacity to meet the rapidly growing demand for advanced voice, data and video communications over mobile wireless systems.

ExteNet's distributed networks serve many communities across North America. Ongoing support for our communities is a core value for the entire company. Our goal is to continually engage and cooperate with residents and local officials to enable advanced and reliable cellular and Wi-Fi services and ultimately provide superior mobile connectivity for the people who live, work, grow and play in the community.

Mobile wireless connectivity is essential for everyone today. Businesses depend on connectivity for productivity and efficiency. People need connectivity to communicate, to conduct their daily activities and stay in touch with their family and friends. In life-saving and other critical scenarios, reliable and on the scene connectivity is needed to reach 911 to deploy first responders in the shortest timeframe.

BENEFITS

- Improved capacity and coverage
- Increased wireless speeds
- Smaller form-factor and less obtrusive than towers
- Public safety
- Carrier neutral host approach reduces proliferation of equipment

Thank You!

The logo for extenet SYSTEMS, featuring the word "extenet" in a lowercase, sans-serif font with a registered trademark symbol, and "SYSTEMS" in a smaller, uppercase, sans-serif font below it. A white line with a circular end extends from the top left of the logo towards the right side of the slide.

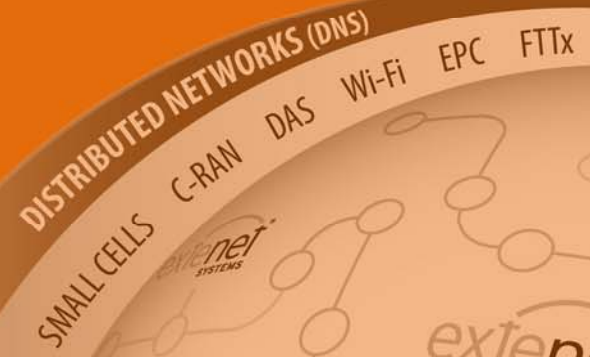
A curved banner containing several network-related terms: "DISTRIBUTED NETWORKS (DNS)", "SMALL CELLS", "C-RAN", "DAS", "Wi-Fi", "EPC", and "FTTx". The banner is light orange and has a subtle network diagram pattern.

A smaller version of the extenet SYSTEMS logo, located in the bottom right corner of the slide.