

1 FLOOR PLAN PROPOSED  
 1/8" = 1'-0"

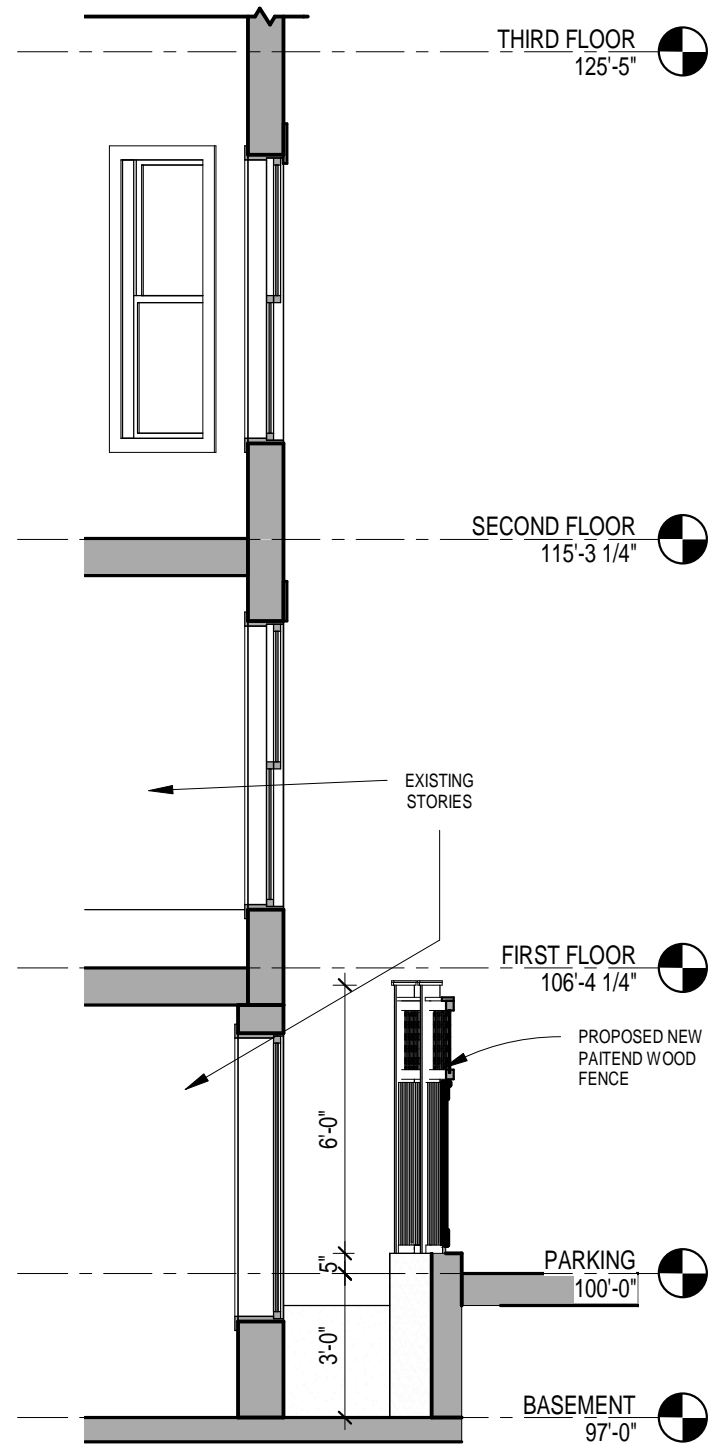

2 SECTION  
 1/4" = 1'-0"

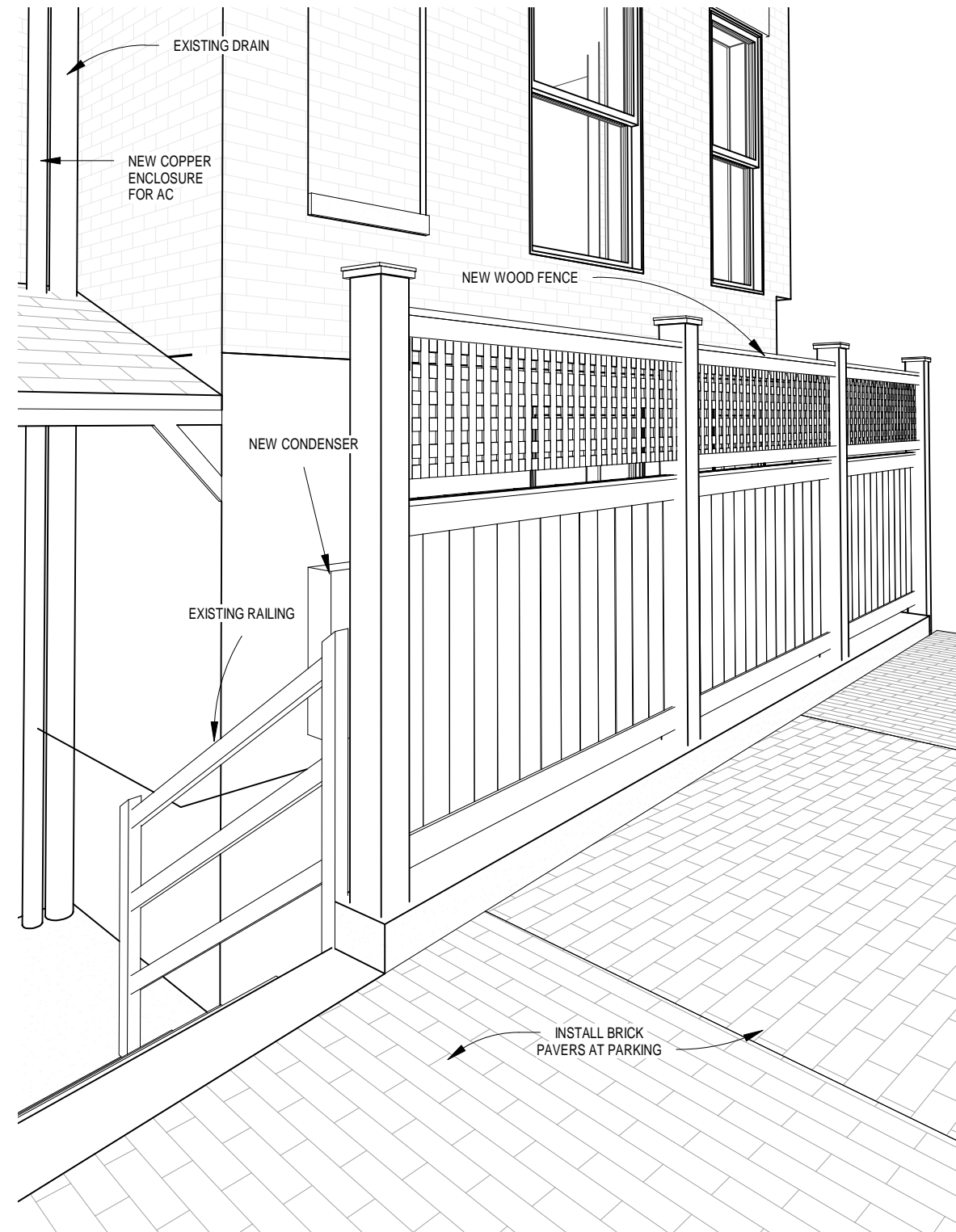

3 3D View 1

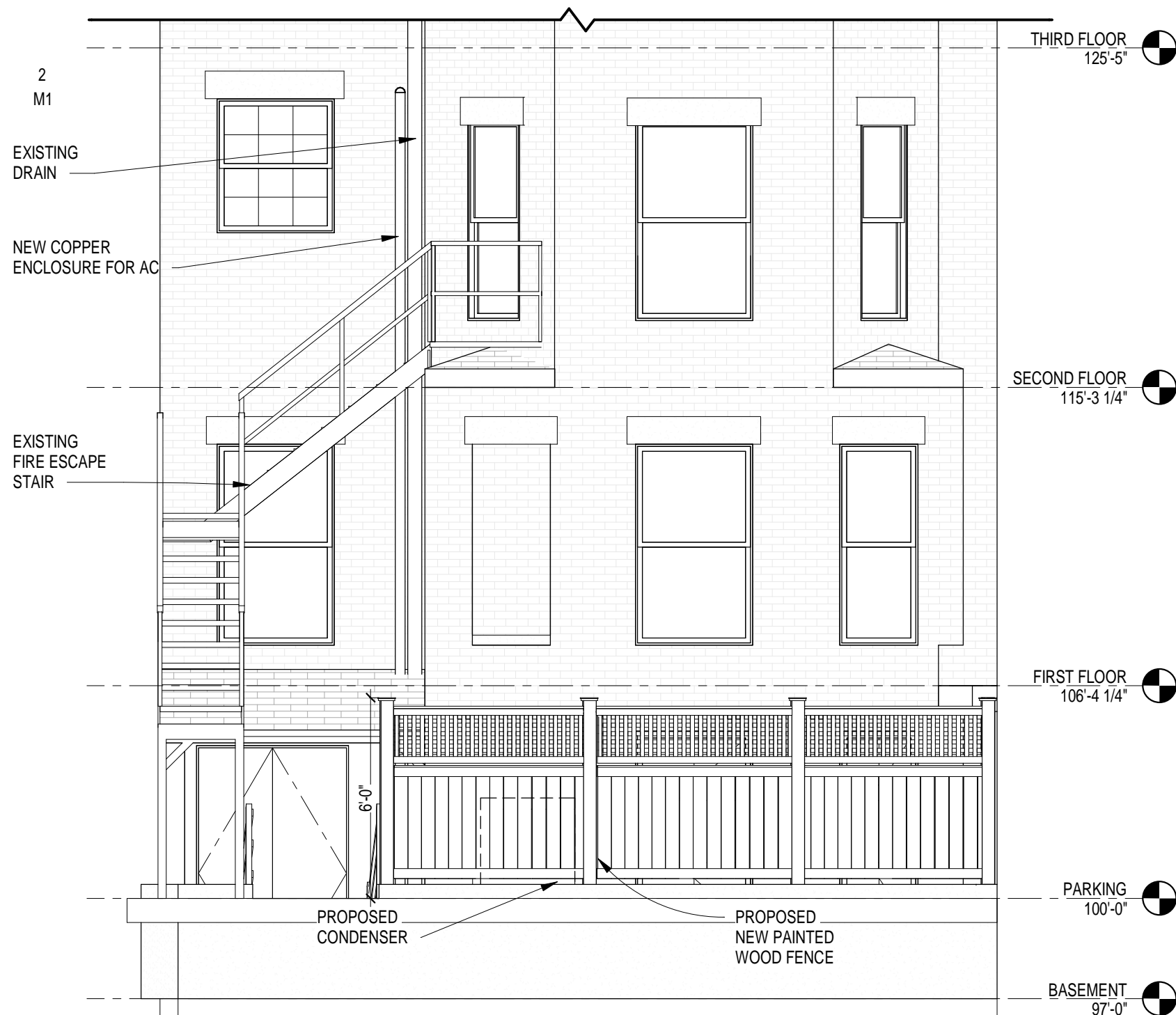

**1 ELEVATION**  
1/4" = 1'-0"

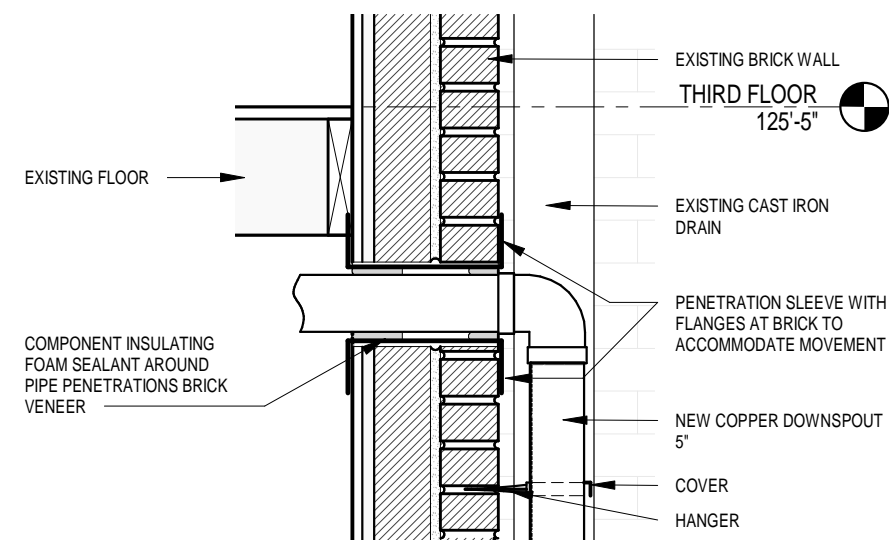

**2 TYP. PIPE PENETRATION**  
1" = 1'-0"

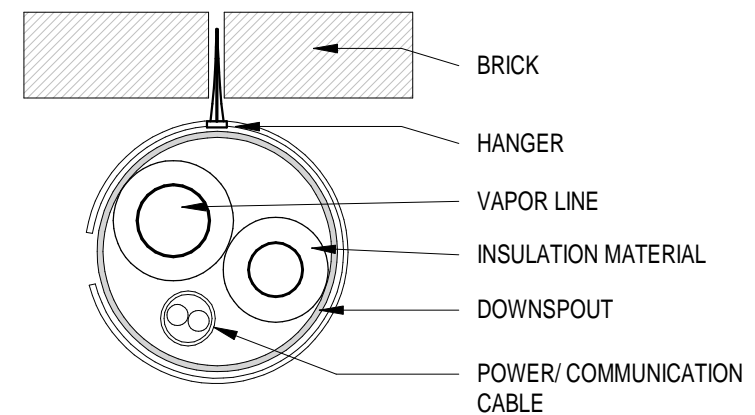

**3 TYPICAL CONDUIT**  
1 1/2" = 1'-0"

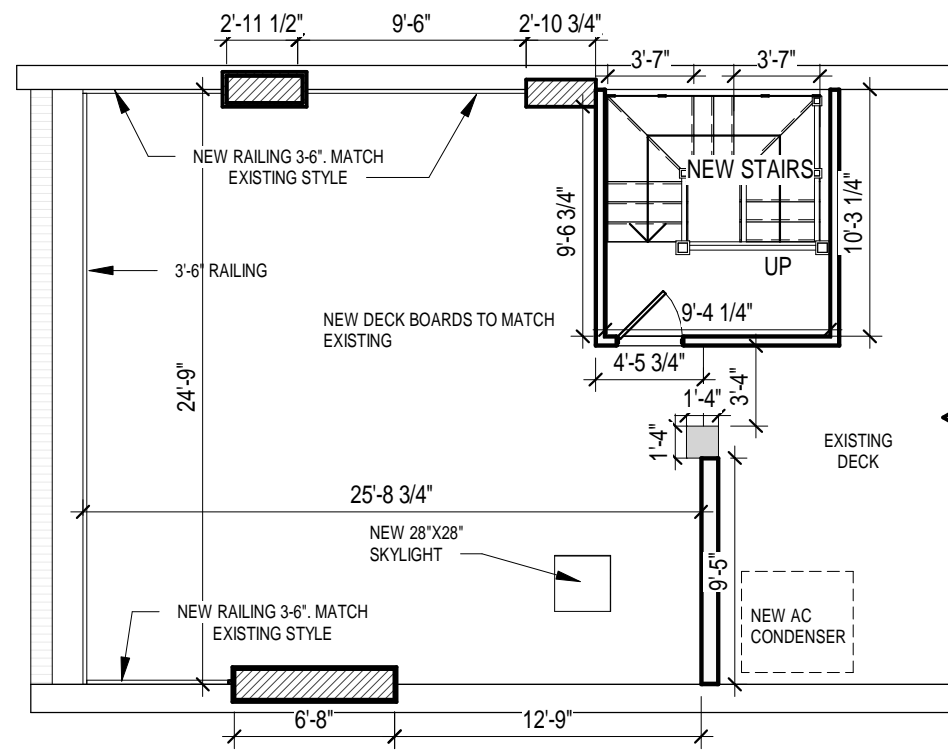

1 ROOF PLAN  
1/8" = 1'-0"

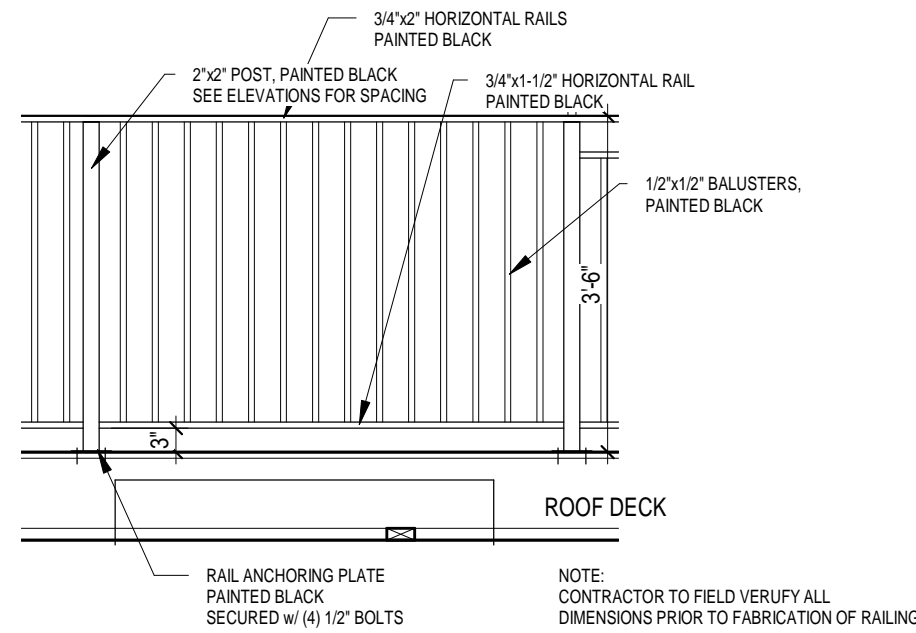

3 RAILING DETAIL  
1/2" = 1'-0"

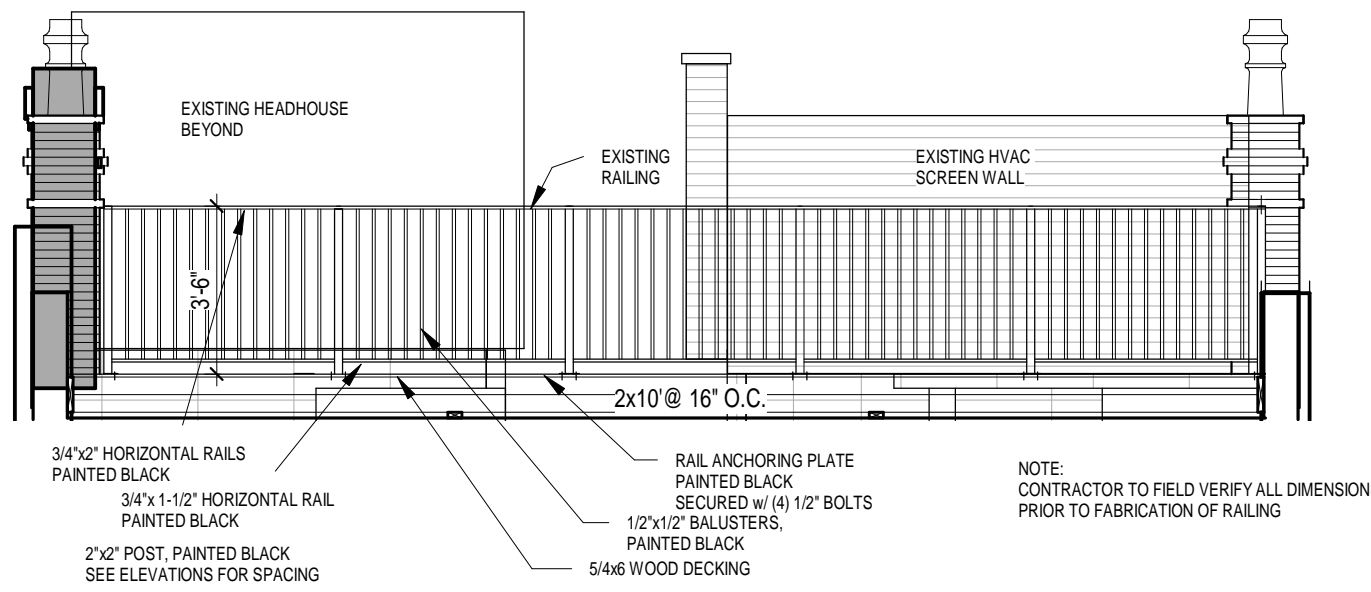

2 ROOF DECK ELEVATION - NORTH  
1/4" = 1'-0"

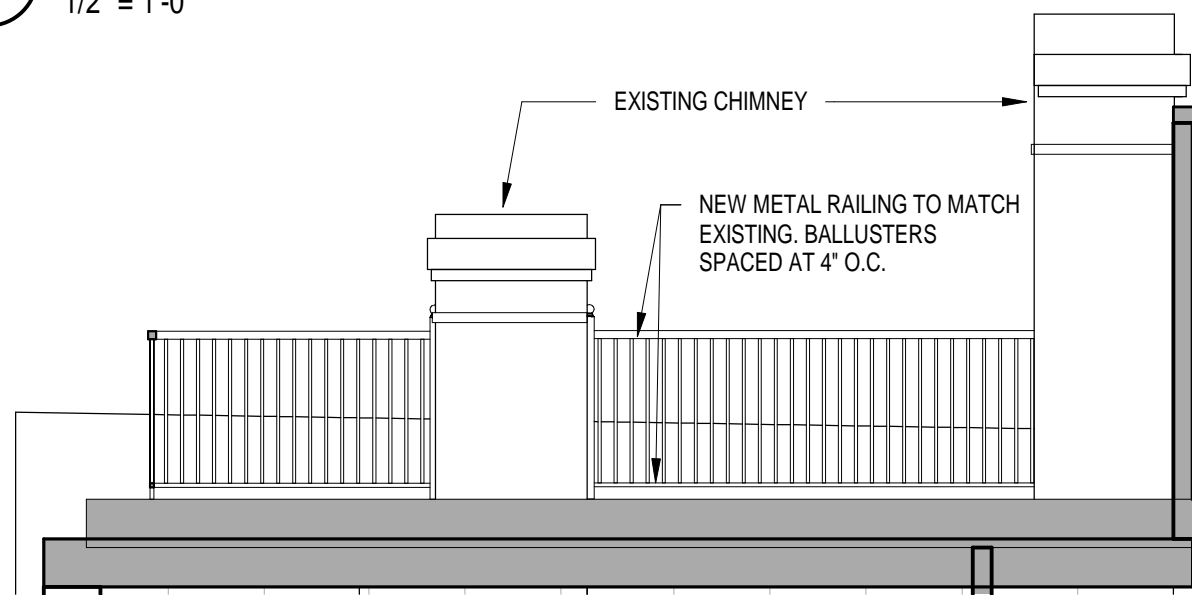

4 ROOF DECK ELEVATION - EAST  
1/4" = 1'-0"

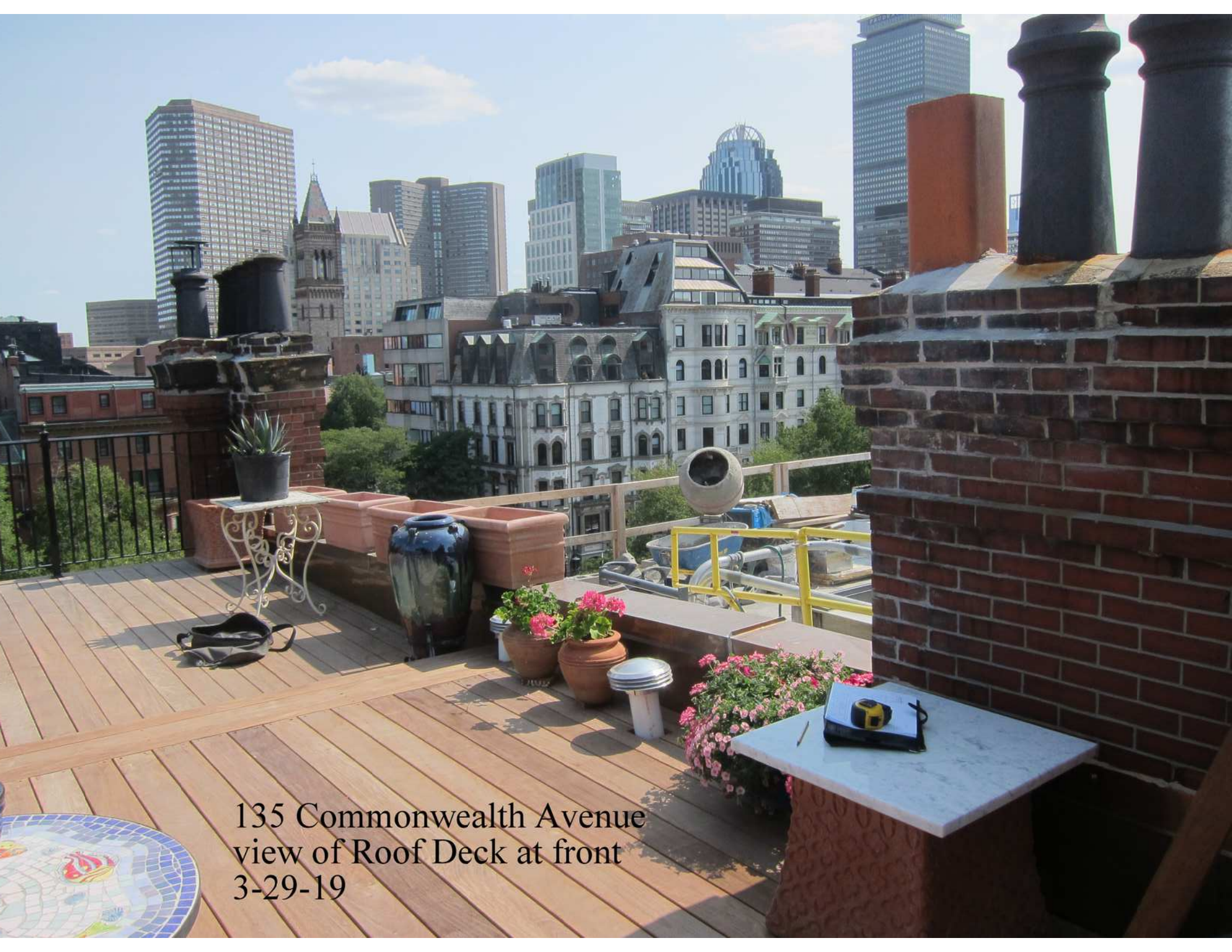

135 Commonwealth Avenue  
view of Roof Deck at front  
3-29-19



135 Commonwealth Avenue View of Existing Roof Deck 3-29-19

135 Commonwealth Avenue  
View of rear facade 3-15-19





135

135 Commonwealth Avenue  
View of rear door 3-15-19

AUTHORIZED  
PARKING ONLY  
VIOLATORS WILL BE  
TOWED AT OWNERS EXPENSE

135 Commonwealth Avenue  
View of retaining wall 3-15-19







1  
3  
3

WARNING  
24  
HOUR  
SURVEILLANCE  
Trespassers Will Be  
Prosecuted

135 Commonwealth Avenue  
View above rear entry 3-15-19

5

Roof deck

135 Commonwealth Avenue  
View of rear from Dartmouth Street  
3-15-19

151  
comm



# DIMENSIONS: MUZ-GL18NA

Unit: inch

## REQUIRED SPACE

\*1 20 in. or more when front and sides of the unit are clear

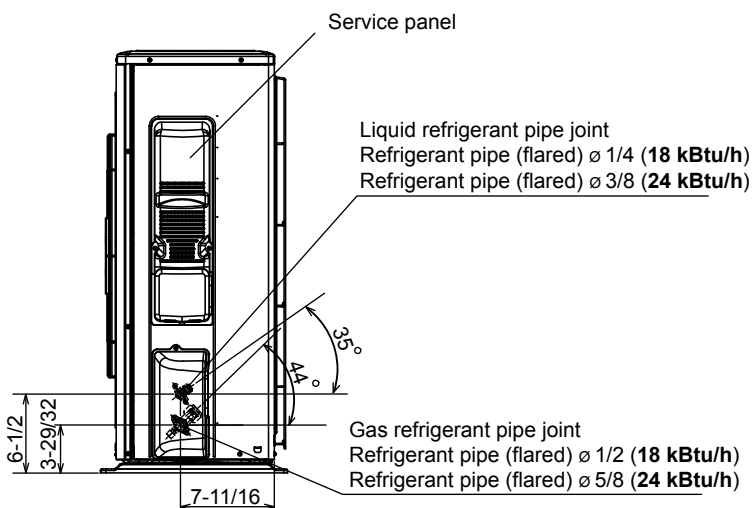
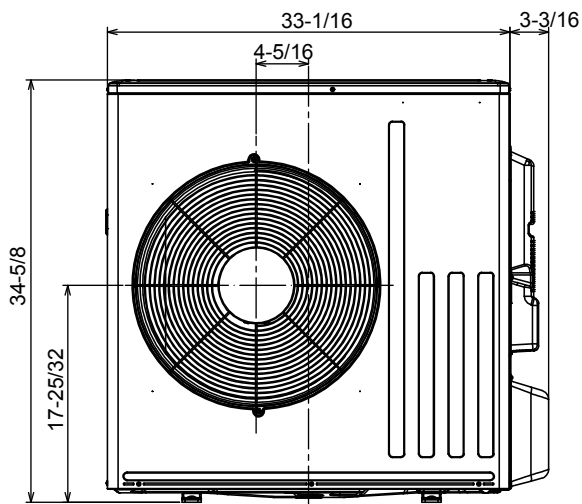
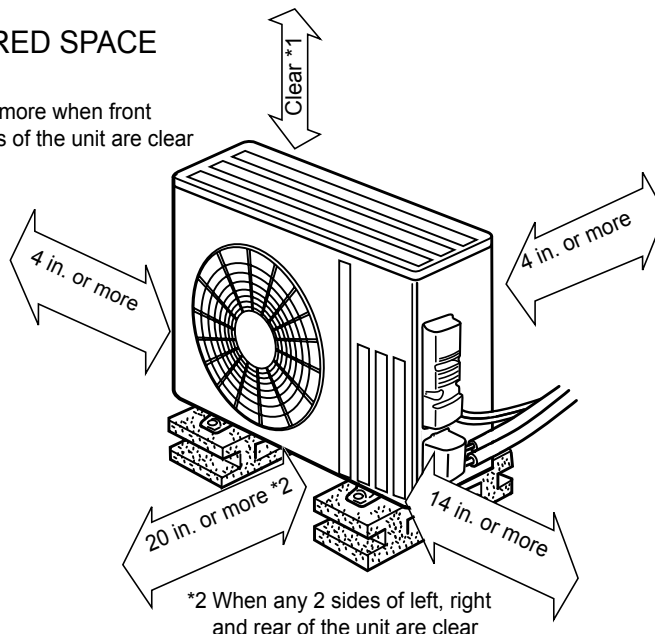
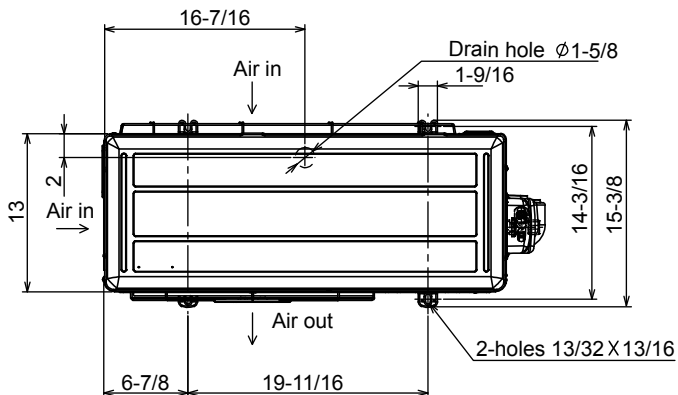

1340 Satellite Boulevard, Suwanee, GA 30024  
Toll Free: 800-433-4822 www.mehvac.com

FORM# MSZ-GL18NA / MUZ-GL18NA - 201902



Specifications are subject to change without notice.

© 2019 Mitsubishi Electric Trane HVAC US LLC. All rights reserved.