

64 W RUTLAND SQ

BOSTON, MA 02118

SEDC

01/22/2020



EMBARC

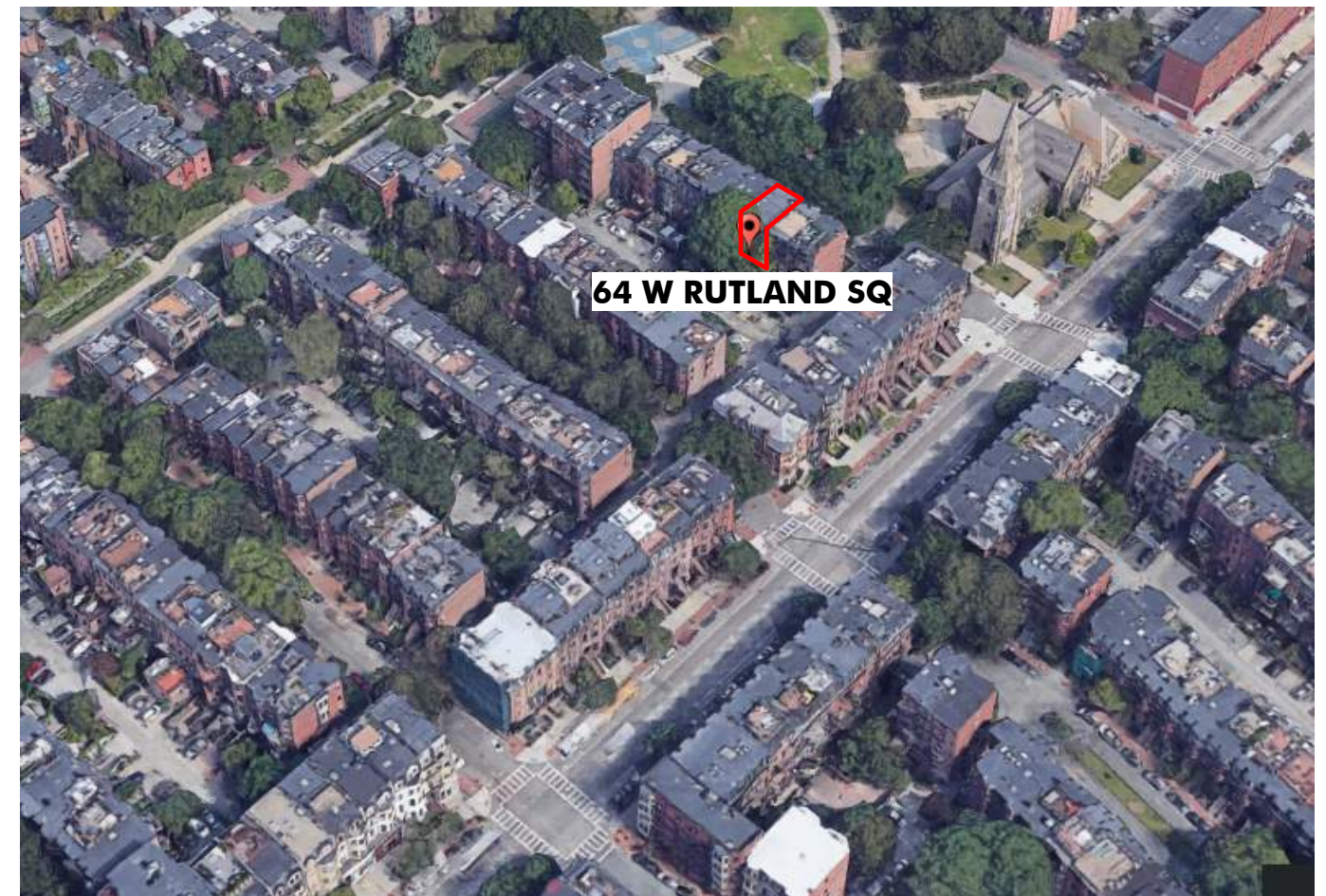
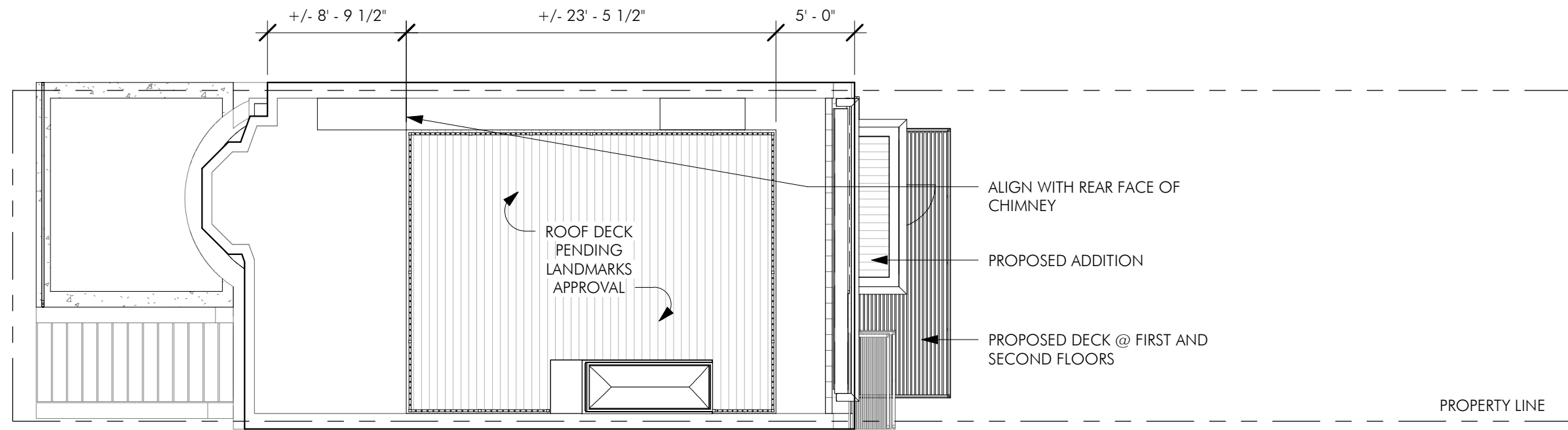





1 RUTLAND SQUARE ELEVATION - PROPOSED
1/8" = 1'-0"





EXISTING PATIO AT MANSARD ROOF

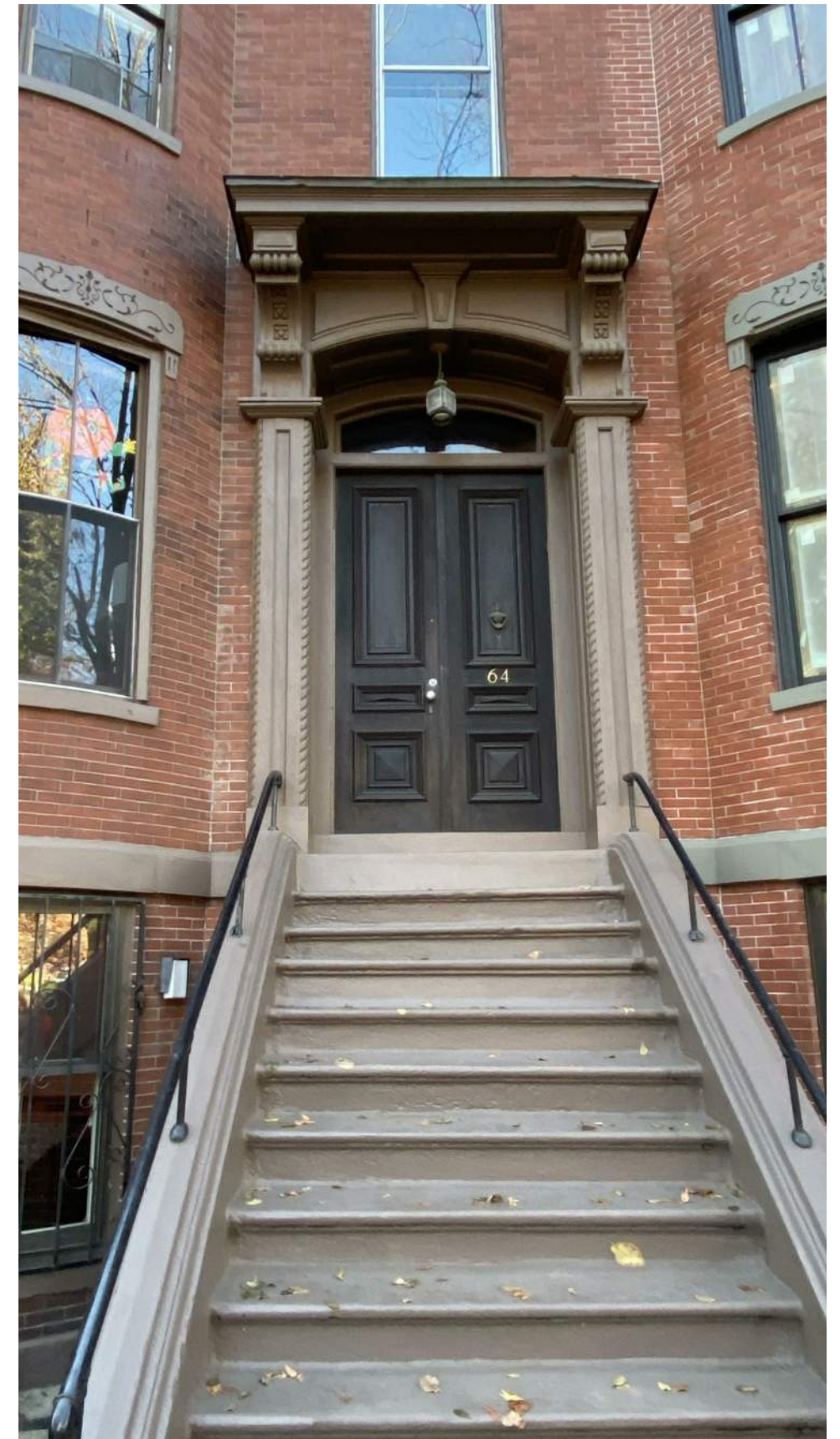

EXISTING PATIO AT MANSARD ROOF



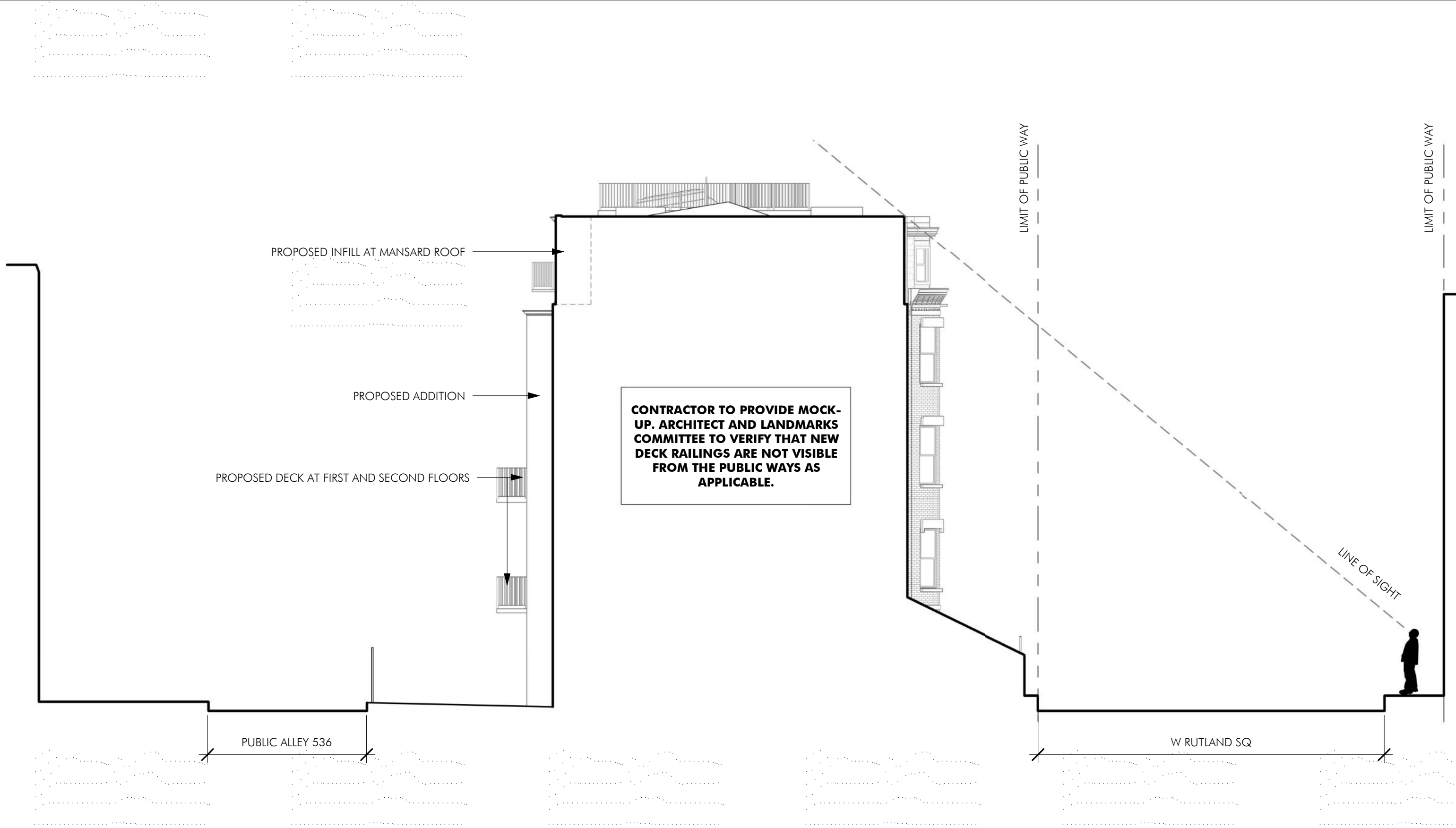



1 REAR ELEVATION - PROPOSED
1/8" = 1'-0"



2 REAR ELEVATION - EXISTING
1/8" = 1'-0"

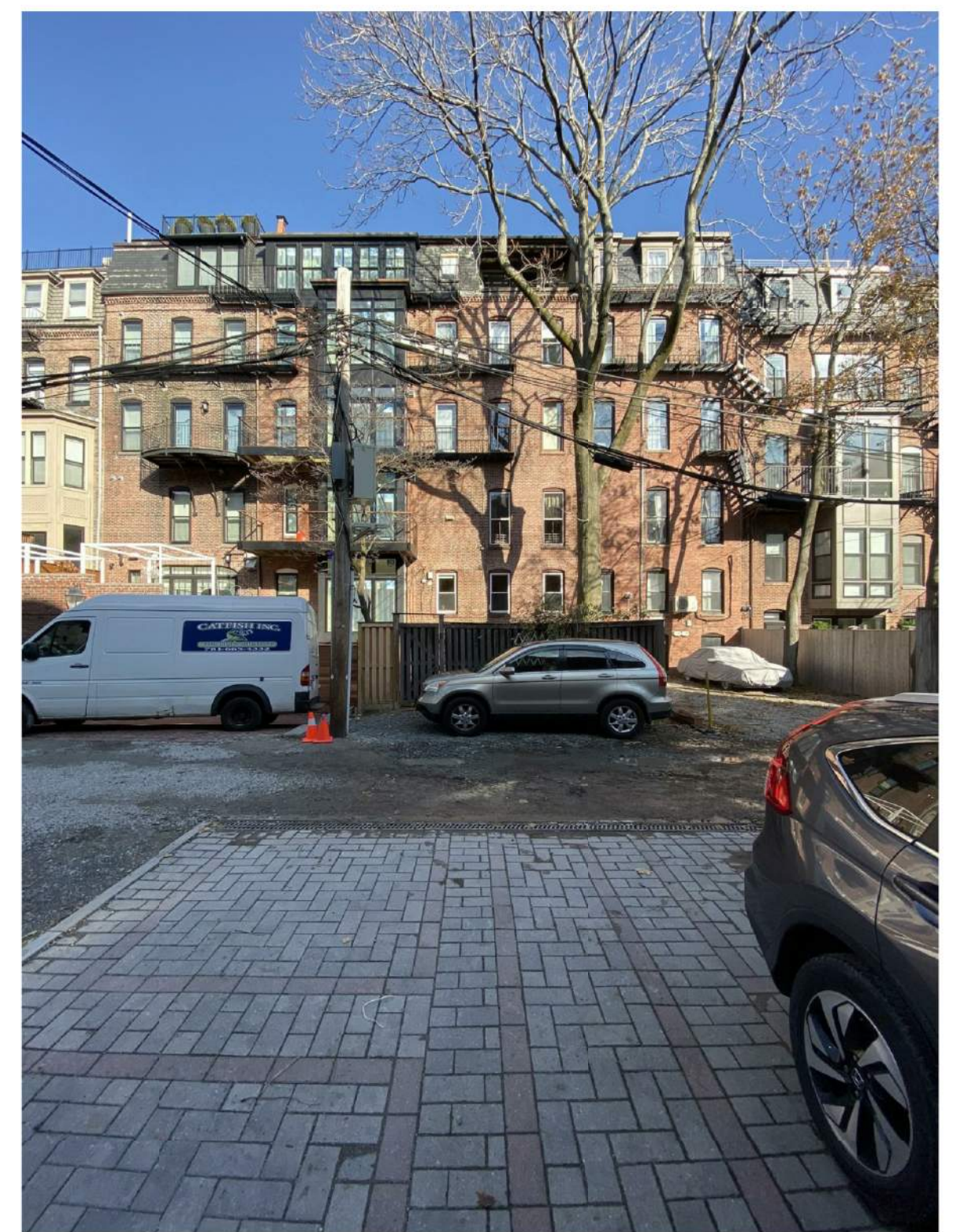

66 W RUTLAND

64 W RUTLAND

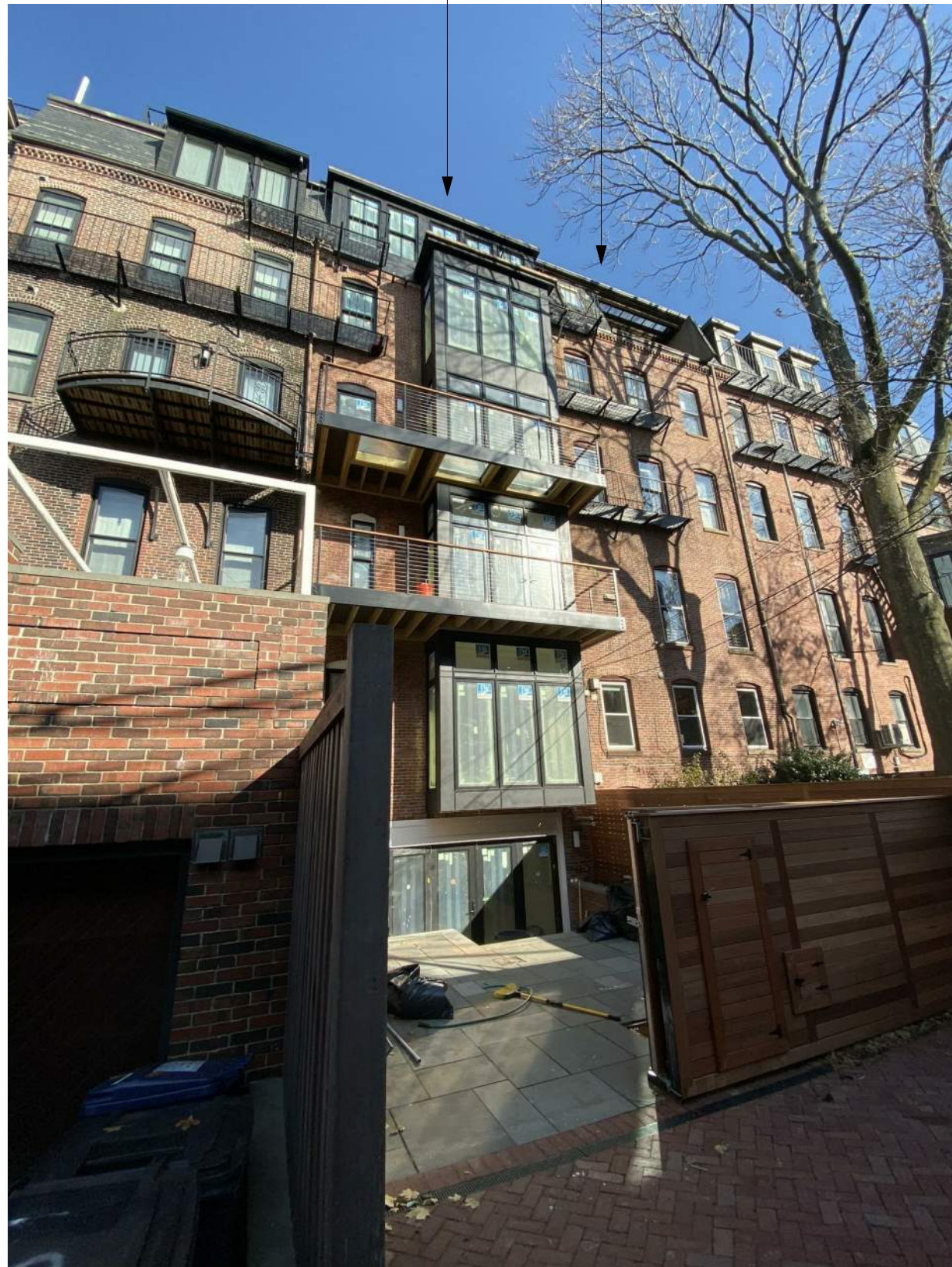

REAR PRECEDENT



REAR ELEVATION

64 W RUTLAND SQ
BOSTON, MA 02118

01/22/2020

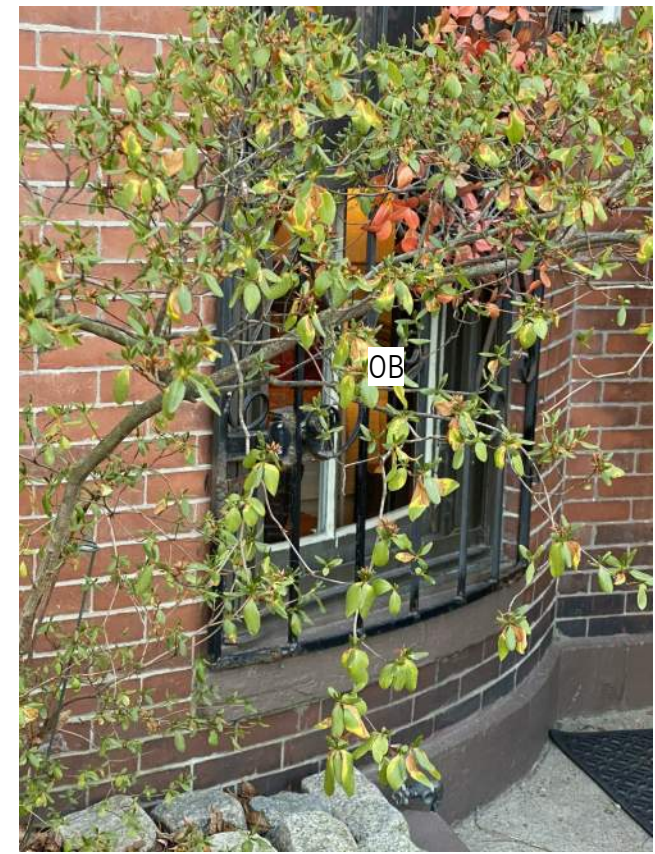



0A

TYPICAL OF 0A, 0B



1A



2A



3A



0B

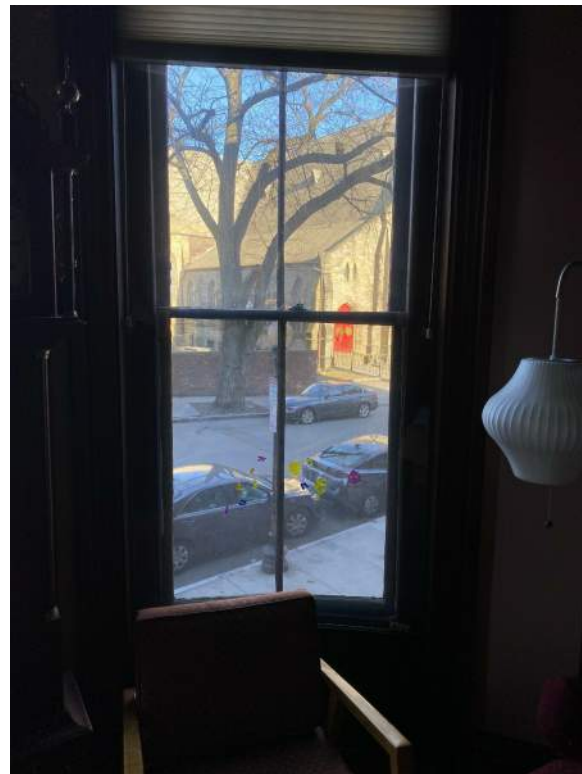

1B



2B

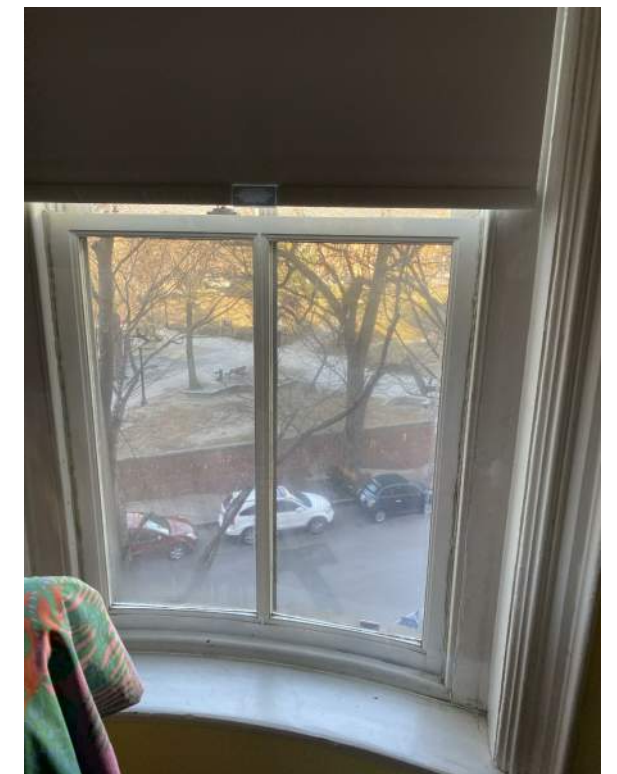

3B



4A



4B

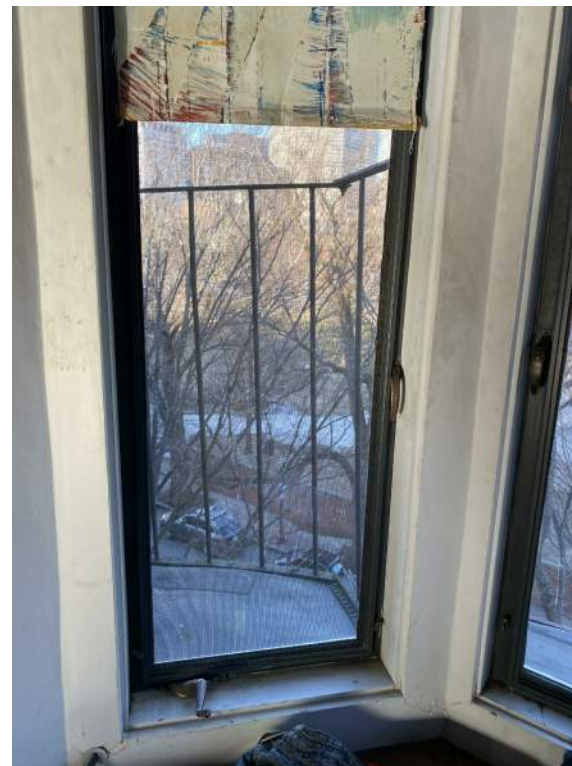

4C



4D



4B



4C



4D



4D

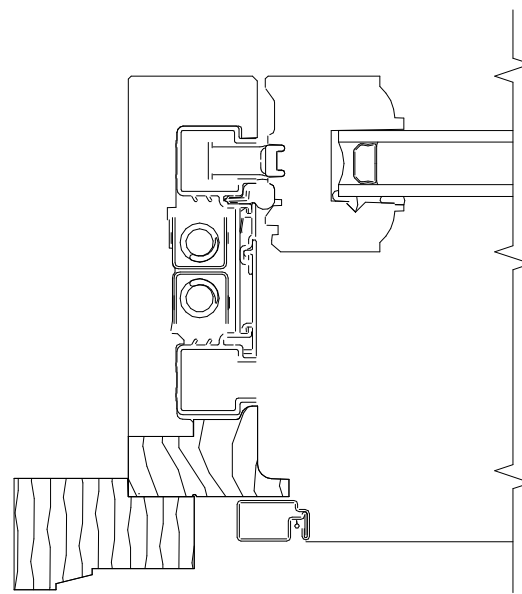
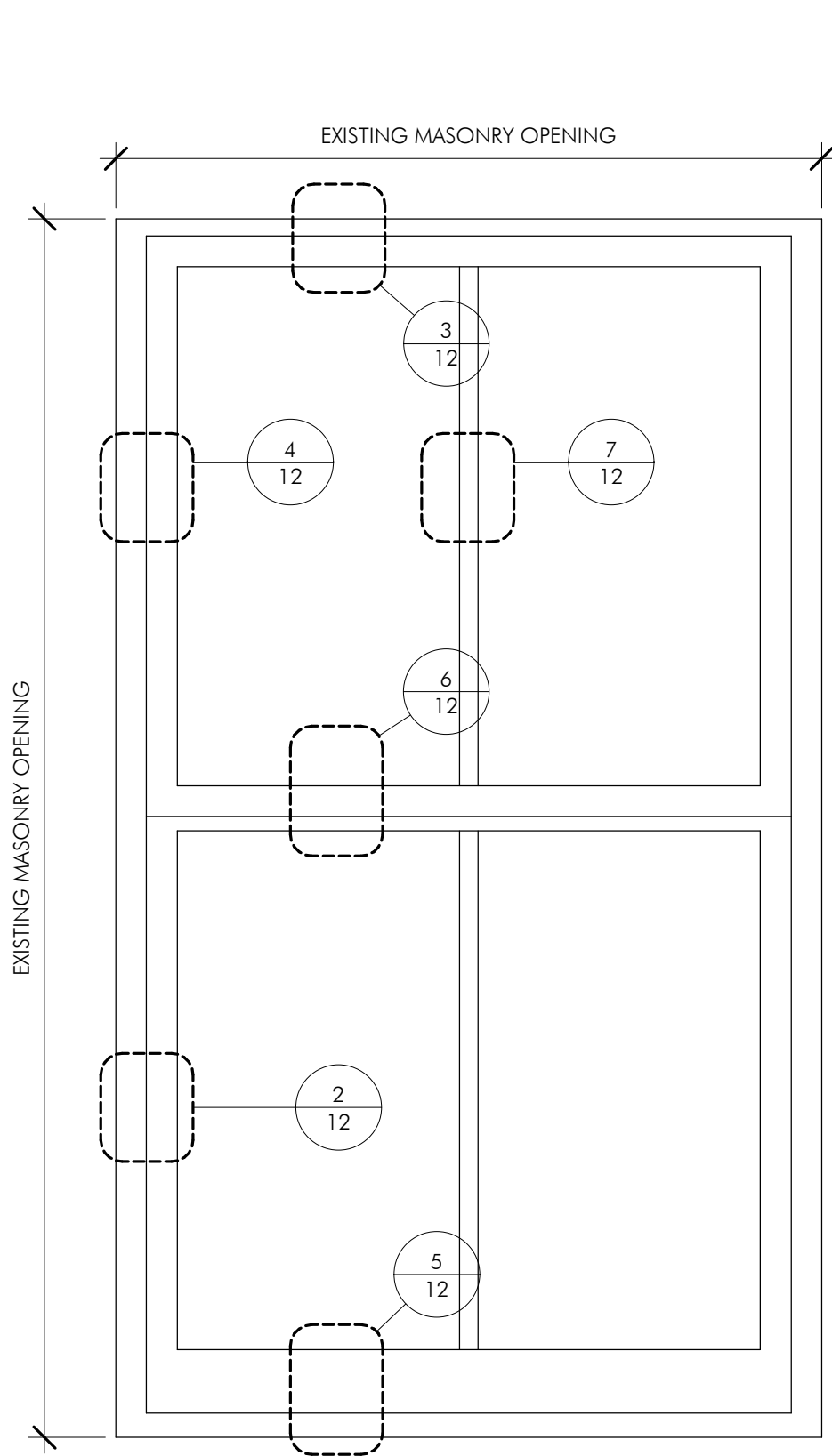

2 LOWER JAMBS
6" = 1'-0"

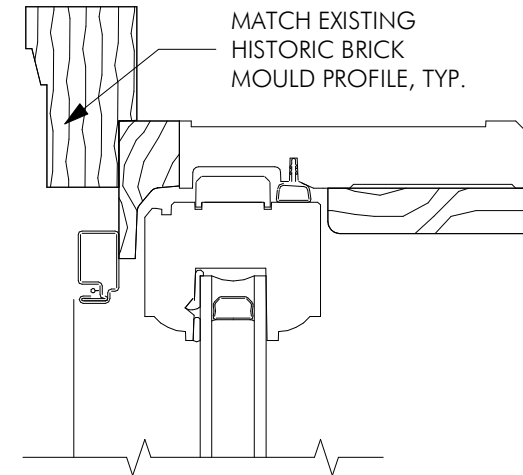

3 VENT HEAD
6" = 1'-0"

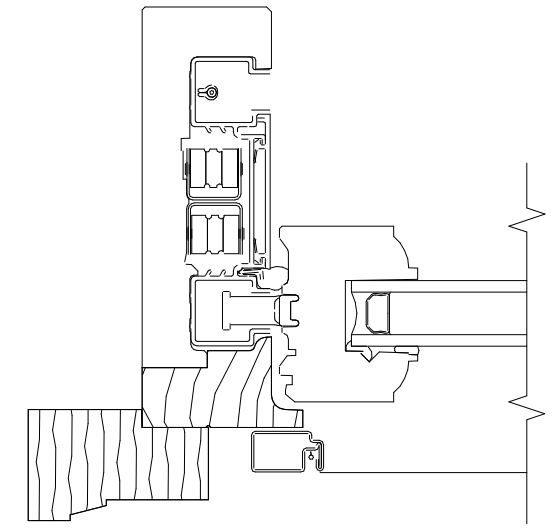

4 UPPER JAMBS
6" = 1'-0"

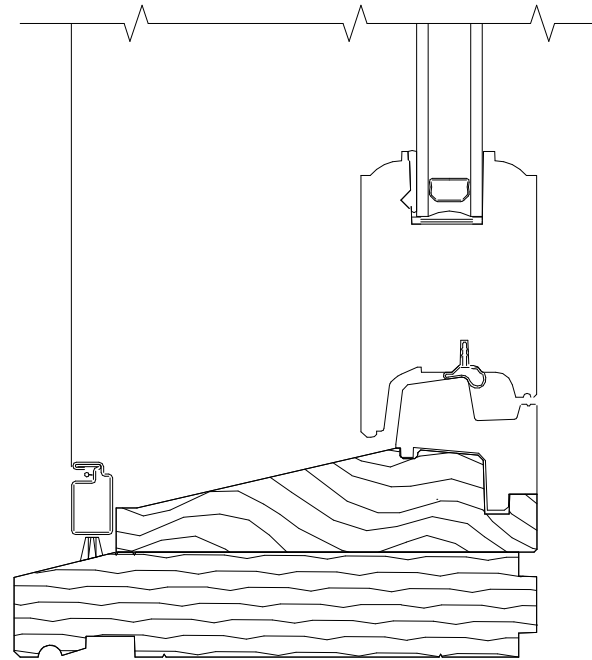

5 VENT SILL
6" = 1'-0"

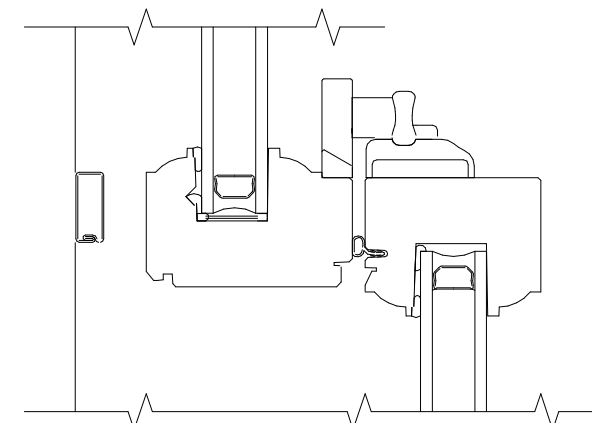

6 CHECK RAIL
6" = 1'-0"

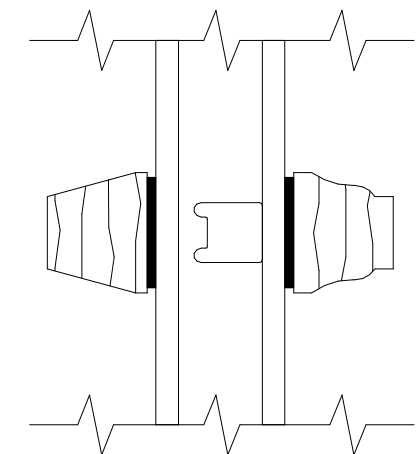

7 GLAZE GRILLES
12" = 1'-0"