

WEST NEWTON STREET AND RUTLAND STREET APARTMENTS

54-102 WEST NEWTON STREET,
BOSTON (SOUTH END)

SOUTH END LANDMARK DISTRICT COMMISSION HEARING
PRESENTATION



**DOOR FABRICATION DRAWINGS (2020): DOOR TYPE A
(54-64 AND 68 WEST NEWTON STREET)**

SINGLE DOOR UNIT W/ SIDELITES & TRANSOM
 PRIMED SAPELE
 - 4 1/2" DELTANA BRUSHED NICKEL (SOLID BRASS) BB HINGES
 FULL MORTISE LOCK PREP FOR SARGENT 8215 PASSAGE SET
 1" X 5" PRIMED FLAT EXTERIOR SAPELE CASING (SHIPPED LOOSE)

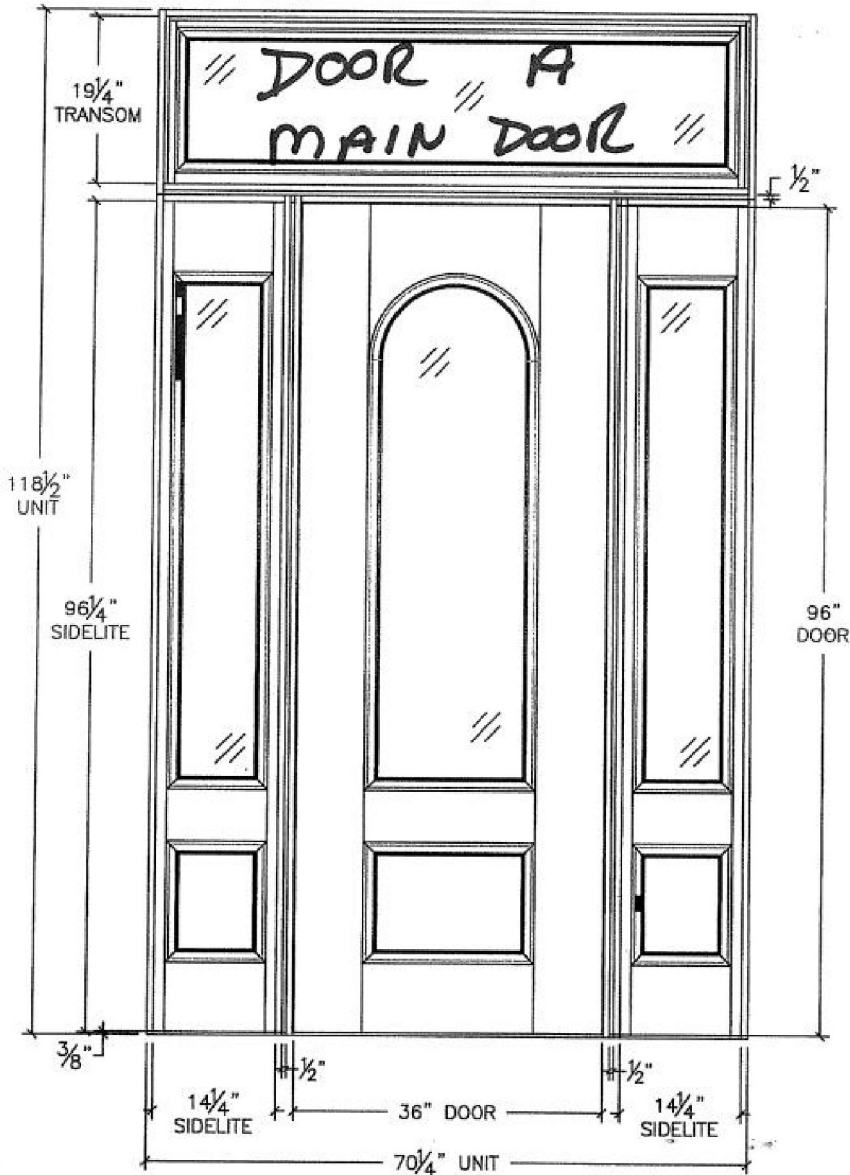
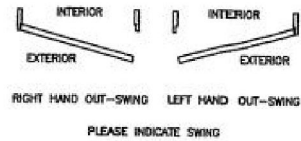

EXTERIOR VIEW
 TYPE A - MAIN



NOTE: NO WARRANTY ON DOORS WITH STILES LESS THAN 5", DOORS WIDER THAN 42" AND/OR OVER 96" TALL.

MERSET DOOR AND COLUMN

SOMERSET, PA (814)444-9427

QUOTE#: 20-0444 DWG#: 20-0444-1

REVISION #:

DATE OF REV.:

THESE ARE WORKING DRAWINGS & ALL DETAILS MUST BE SIGNED. YOUR SIGNATURE INDICATES THAT YOUR SPECIFICATIONS HAVE BEEN MET.

CUSTOMER NAME: MOZZONE LUMBER

DRAWN BY: DW

APPROVED BY:

DATE: 6-25-20

**DOOR FABRICATION DRAWINGS (2020): DOOR TYPE B
(66 WEST NEWTON STREET)**

66 West Newton Street

EXTERIOR DOUBLE DOOR UNIT W/ TRANSOM

PRIMED SAPELE

3 - 4 1/2" BB SATIN NICKEL HINGES

-ASTRAGAL W/ FLUSHBOLTS

ALL MORTISE LOCK PREP FOR SARGENT 8215 PASSAGE LOCK

1" X 5" PRIMED FLAT SAPELE CASING (SHIPPED LOOSE)

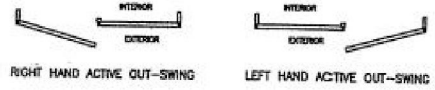

PLEASE INDICATE SWING

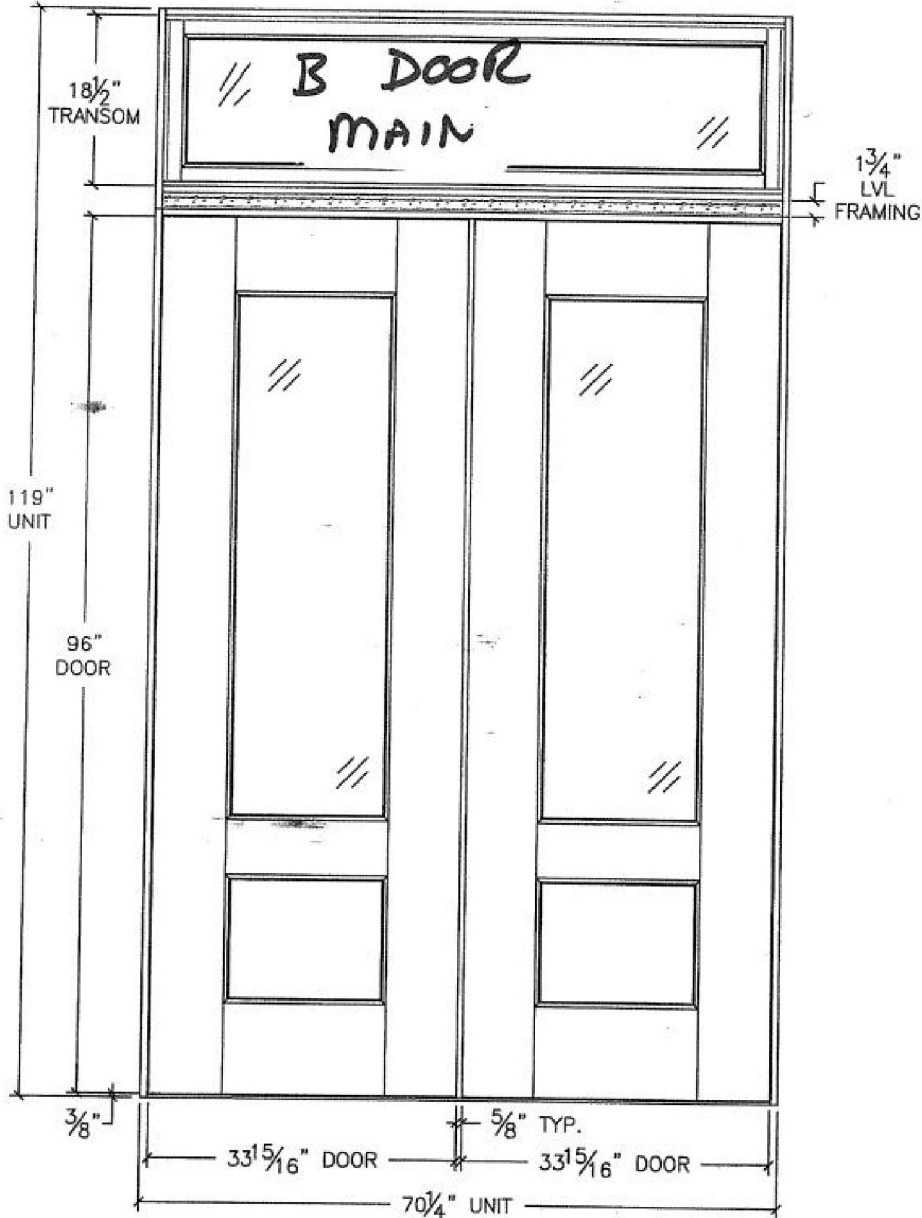

EXTERIOR VIEW
E B - MAIN



DISCLAIMER: NO WARRANTY ON DOORS WITH STILES LESS THAN 5", DOORS WIDER THAN 42" AND/OR OVER 96" TALL.

MERSET DOOR AND COLUMN

SOMERSET, PA (814)444-9427

QUOTE#: 20-0266

DWG#: 20-0266-9

REVISION #:

DATE OF REV.:

THESE ARE WORKING DRAWINGS & ALL DETAILS MUST BE SIGNED. YOUR SIGNATURE INDICATES THAT YOUR SPECIFICATIONS HAVE BEEN MET.

CUSTOMER NAME: MAZZONE LUMBER

DRAWN BY: DW

APPROVED BY:

DATE: 5-27-20

**DOOR FABRICATION DRAWINGS (2020): DOOR TYPE C
(70-102 WEST NEWTON STREET)**

EXTERIOR DOUBLE DOOR UNIT W/ TRANSOM
 PRIMED SAPELE
) - 4 1/2" BB SATIN NICKEL HINGES
 -ASTRAGAL W/ FLUSHBOLTS
 ALL MORTISE LOCK PREP FOR SARGENT 8215 PASSAGE LOCK
 X 5" PRIMED FLAT SAPELE CASING (SHIPPED LOOSE)

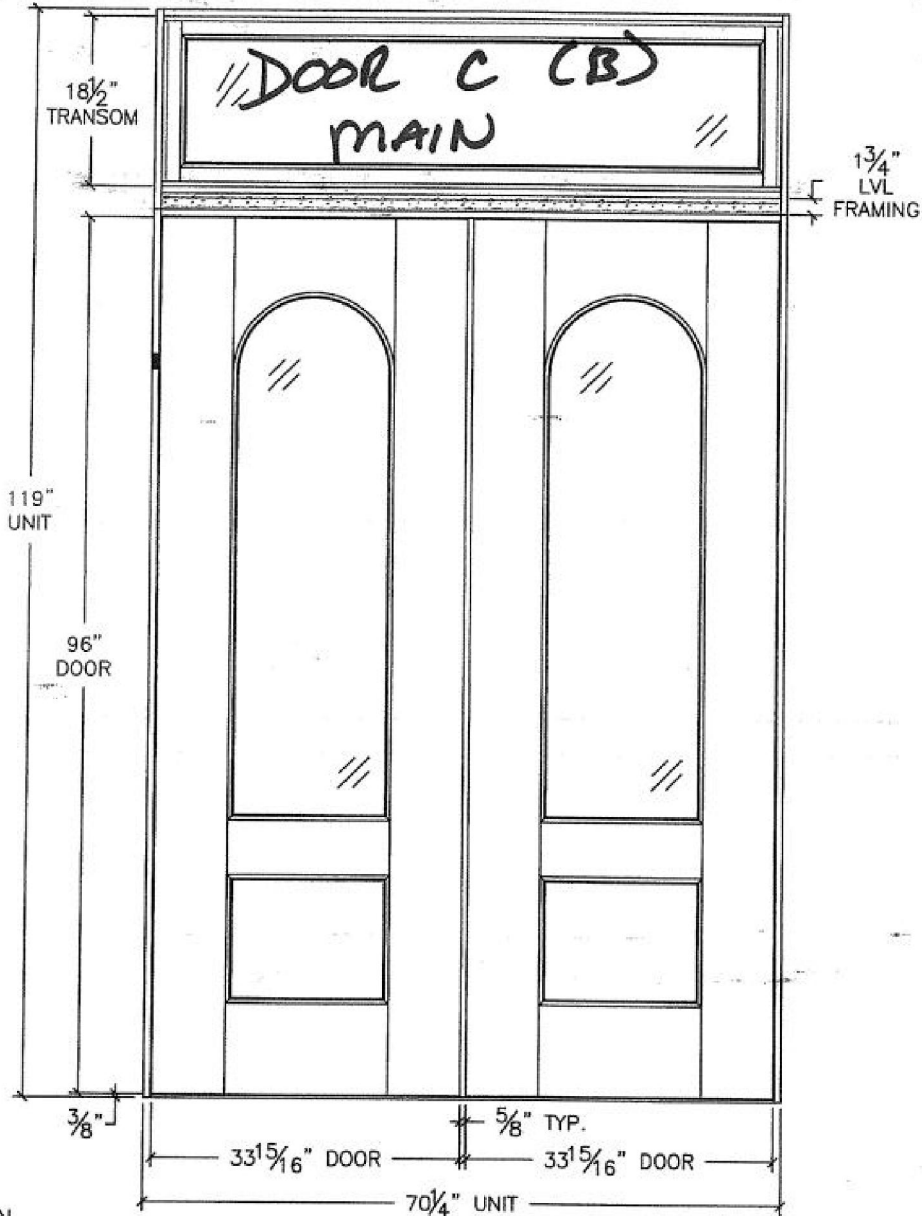
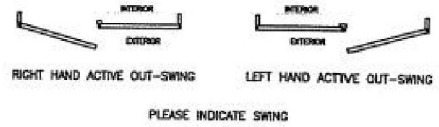

EXTERIOR VIEW
 E C (B) MAIN



WE MAKE NO WARRANTY ON DOORS WITH STILES LESS THAN 5", DOORS WIDER THAN 42" AND/OR OVER 96" TALL.

MERSET DOOR AND COLUMN

SOMERSET, PA (814)444-9427
 QUOTE#: 20-0266 DWG#: 20-0266-10
 REVISION #: DATE OF REV.:

WE ARE WORKING DRAWINGS & ALL DETAILS
 MUST BE SIGNED. YOUR SIGNATURE INDICATES
 THAT YOUR SPECIFICATIONS HAVE BEEN MET.

CUSTOMER NAME: MAZZONE LUMBER
 APPROVED BY:

DRAWN BY: DW
 DATE: 5-27-20

DOOR DETAILS (2017): SHEET A531

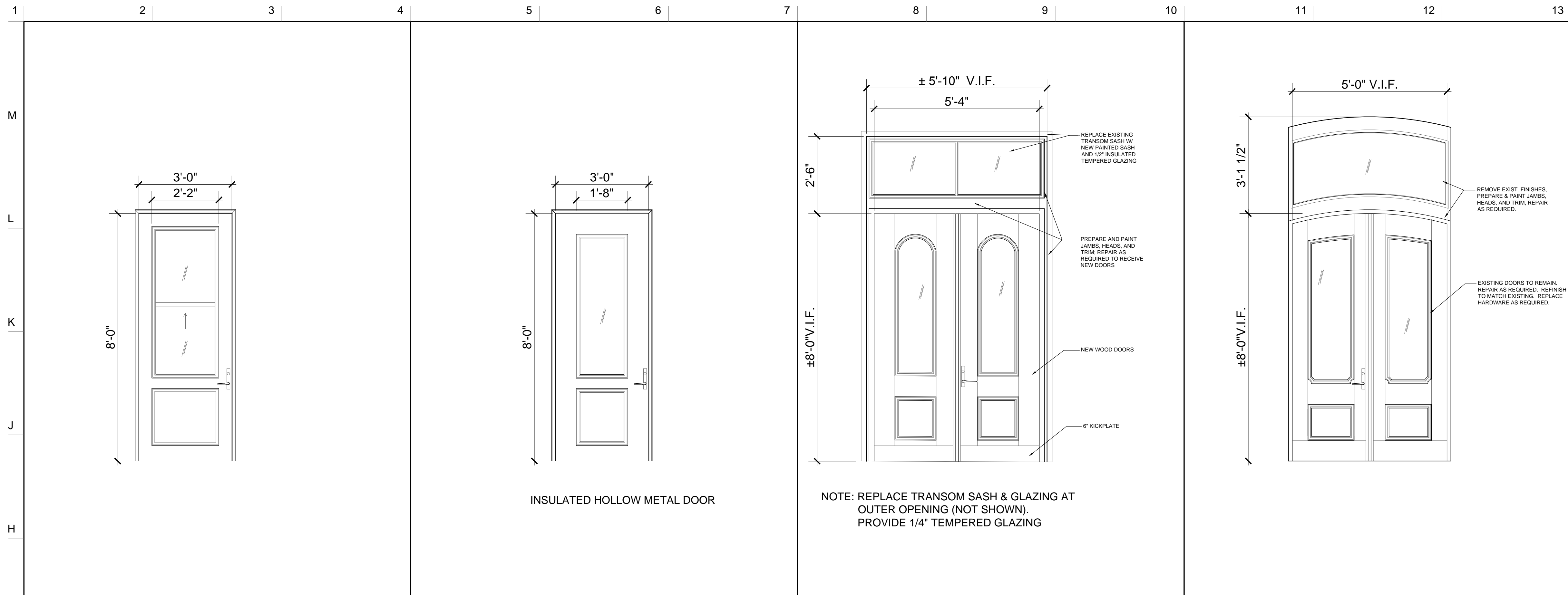

NOTES

DO NOT SCALE DRAWINGS.

REMOVE EXIST. FINISHES, PREPARE & PAINT JAMBS, HEADS, AND TRIM; REPAIR AS REQUIRED.

EXISTING DOORS TO REMAIN. REPAIR AS REQUIRED. REFINISH TO MATCH EXISTING. REPLACE HARDWARE AS REQUIRED.

G1 SCREEN DOOR - REAR ENTRIES

G4 EXT. DOOR - BLDG 54-60, 98-100 WN

G7 EXT. DOOR - BLDG 62-64R

G10 EXT. DOOR - BLDG 79 R

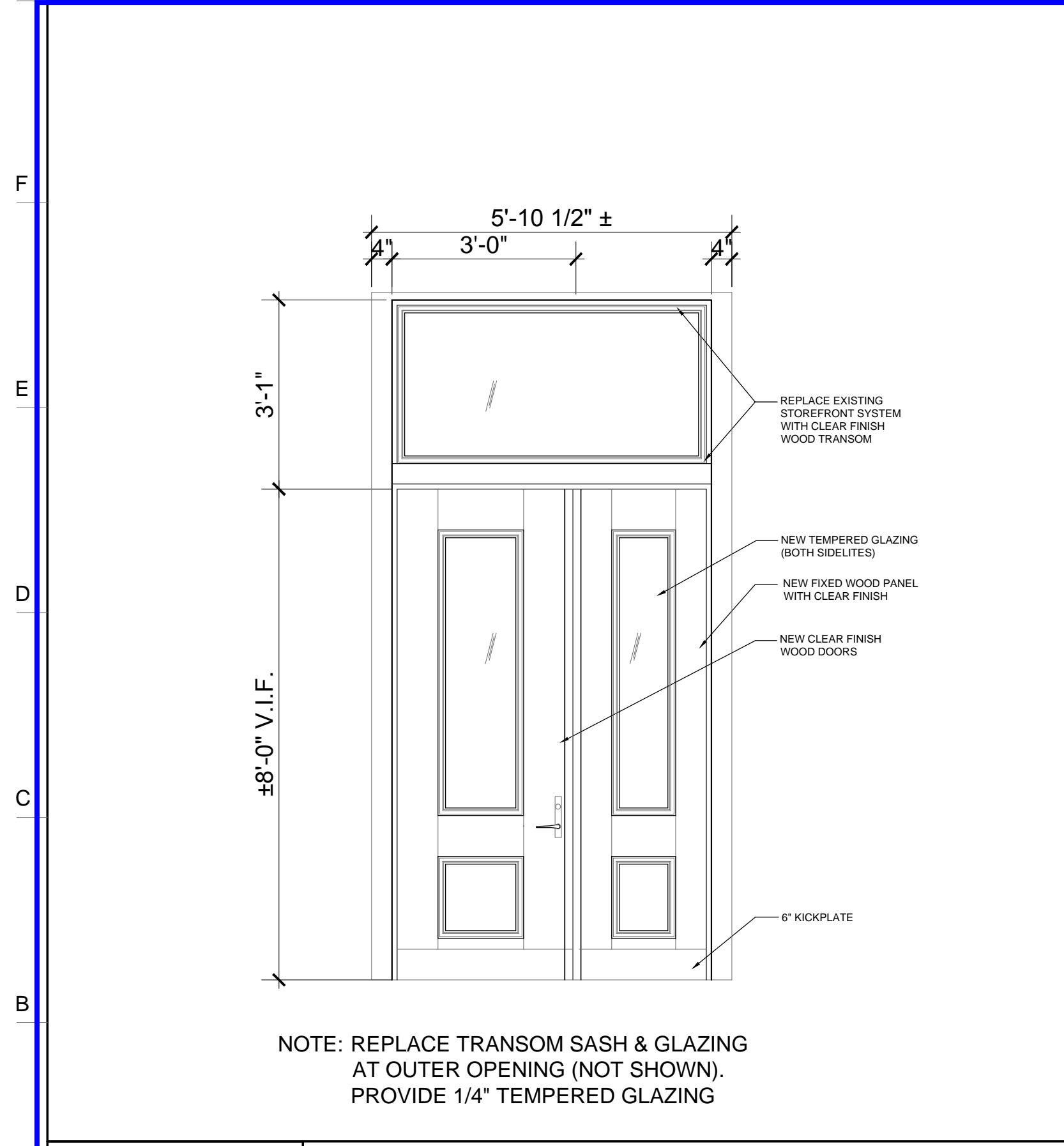

NOTE: REPLACE TRANSOM SASH & GLAZING AT OUTER OPENING (NOT SHOWN). PROVIDE 1/4\"/>

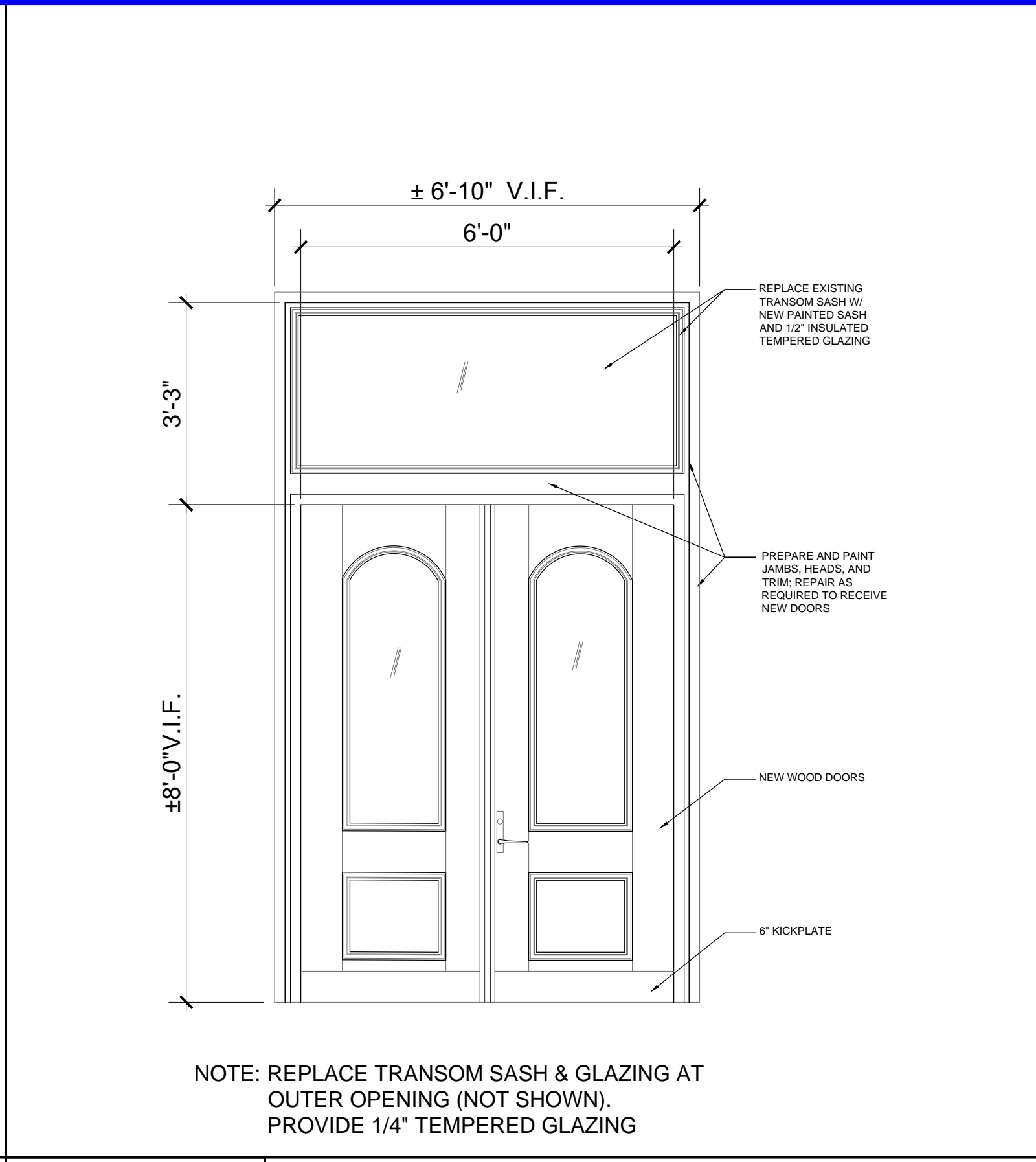

NOTE: REPLACE TRANSOM SASH & GLAZING AT OUTER OPENING (NOT SHOWN). PROVIDE 1/4\"/>

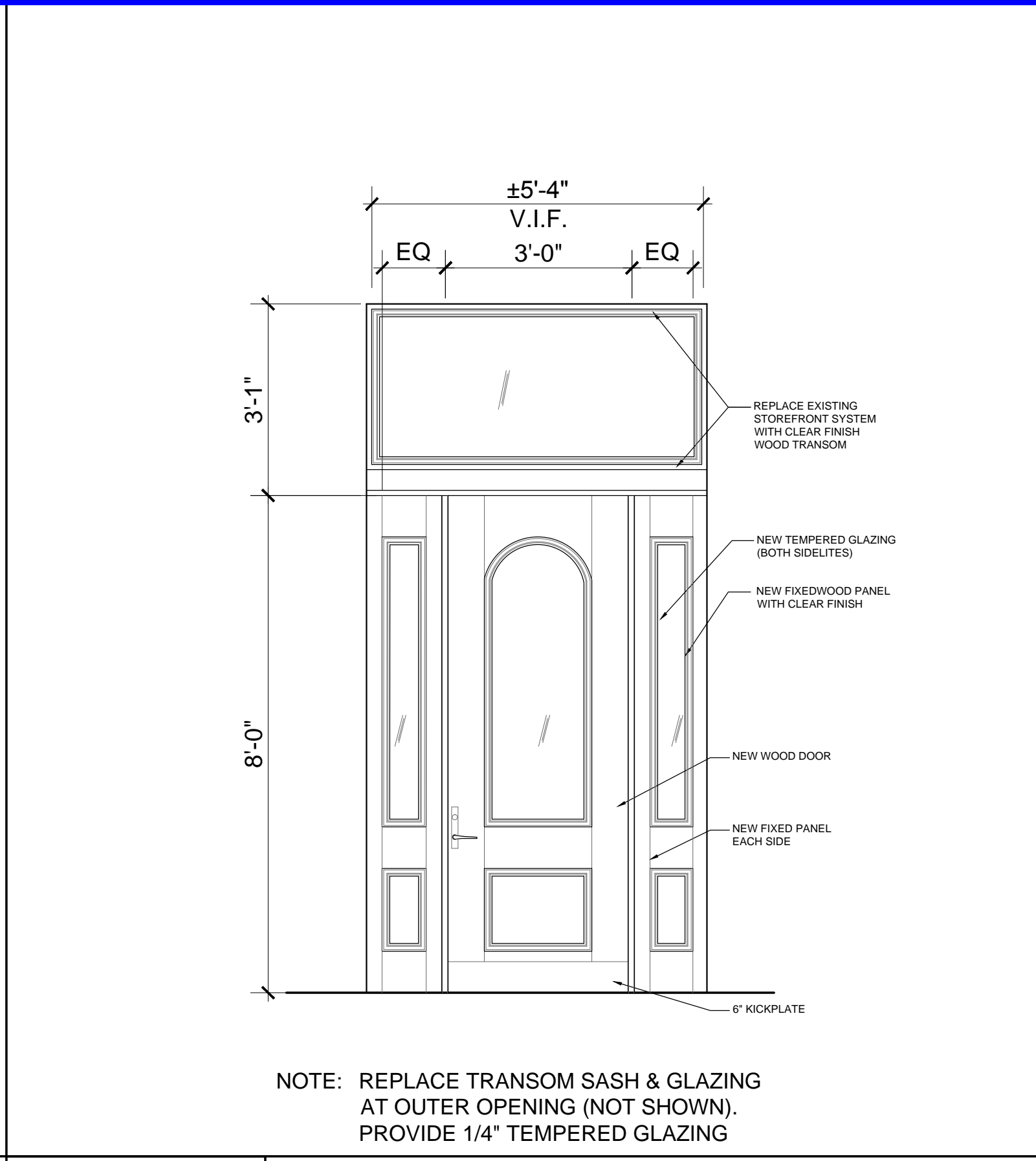

NOTE: REPLACE TRANSOM SASH & GLAZING AT OUTER OPENING (NOT SHOWN). PROVIDE 1/4\"/>



DAVIS SQUARE ARCHITECTS

240A Elm St.,
Somerville, MA 02144
617.628.5700
www.davissquarearchitects.com

Project RENOVATIONS TO WEST NEWTON RUTLAND APARTMENTS BOSTON, MA

Title EXTERIOR DOOR ELEVATIONS

Designed AT	BUILDING/STREET NUMBER
Checked	
Project No. 16015.00	Drawing No.
Scale 1/4"=1'-0"	A531
Date 12.23.16	

A531

EXTERIOR HANDRAIL DETAILS (SKA-40A, SKA-40B, SKA-40C)

EXISTING BRICK AND/OR STUCCO SIDEWALLS TO BE REPAIRED AFTER REMOVAL OF EXISTING HANDRAILS - DAMAGED BRICK TO BE REPLACED AND DAMAGED STUCCO TO BE PATCHED TO MATCH EXISTING

REMOVE EXISTING HANDRAIL AND BRACKETS FROM WALL

METAL 1-3/4" 'DIXIE' CAP RAIL WITH LAMBS TONGUE AT ENDS

1-1/4" SQ. METAL POSTS AT 4'-0" O.C. MAX. TYP. INSTALL POSTS 3" MIN FROM EDGES OF STAIR TREADS AND NOSINGS.

1/2" BALUSTERS AT 4" O.C. WELDED TO TOP AND BOTTOM RAILS.

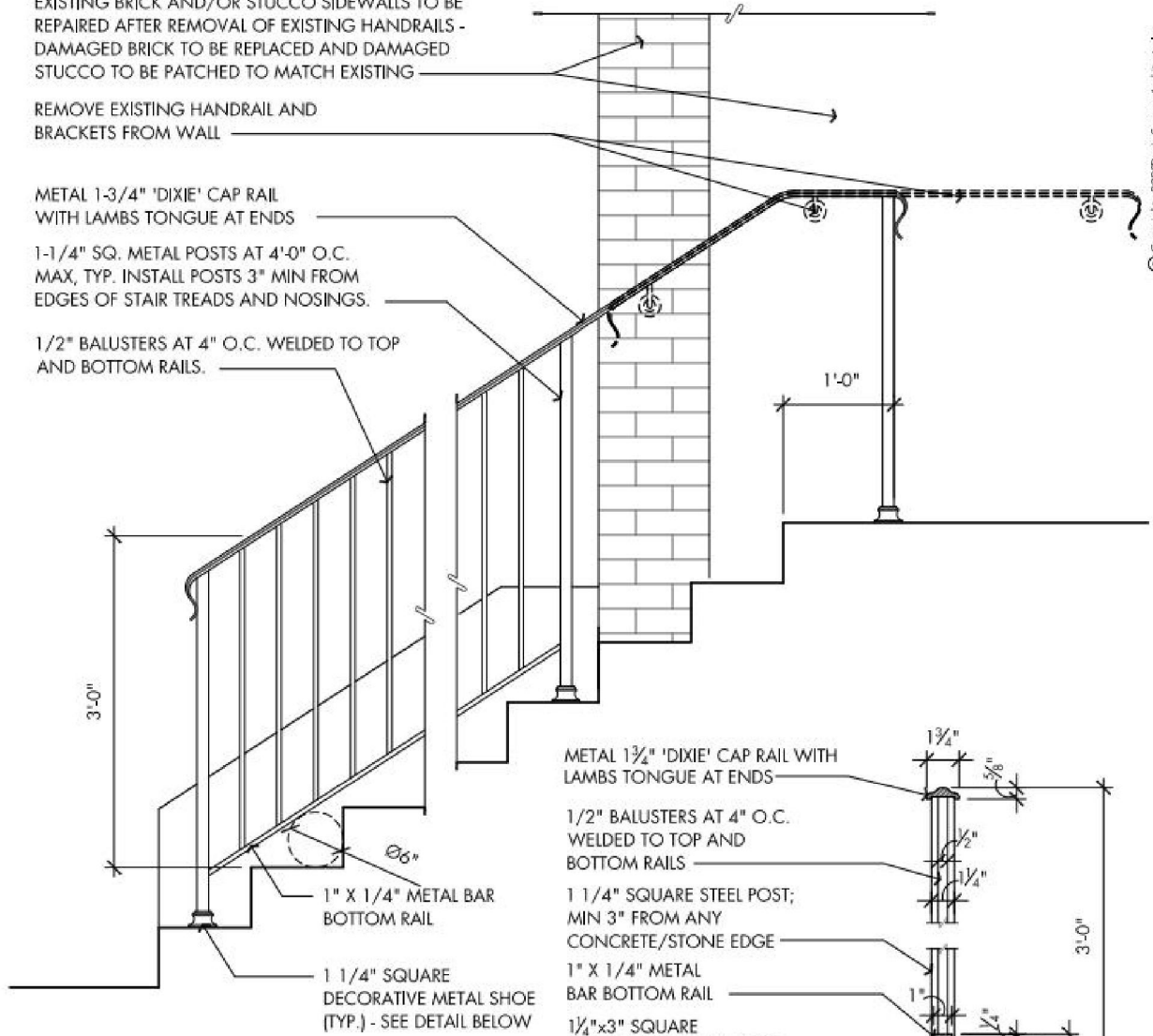

STAIR / RAILING SECTION DETAIL
SCALE: 3/4" = 1'-0"

METAL 1 3/4" 'DIXIE' CAP RAIL WITH LAMBS TONGUE AT ENDS

1/2" BALUSTERS AT 4" O.C. WELDED TO TOP AND BOTTOM RAILS

1 1/4" SQUARE STEEL POST; MIN 3" FROM ANY CONCRETE/STONE EDGE

1" X 1/4" METAL BAR BOTTOM RAIL

1 1/4" SQUARE DECORATIVE METAL SHOE (TYP.) - SEE DETAIL BELOW

3/8" COMPRESSIBLE FILLER JOINT AT ALL SIDES, TYP EACH POST.

3/8" NON-SHRINK GROUT AT ALL SIDES AND BOTTOM OF COLUMN BASE, TYP. EACH POST

STAIR/STAIR LANDING

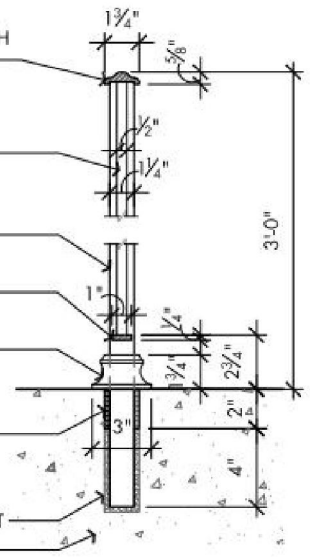

ENLARGED RAILING SECTION DETAIL
SCALE: 1 1/2" = 1'-0"



**DAVIS
SQUARE
ARCHITECTS**

240A Elm St
Somerville, MA 02144
617 628 5700
www.davisquarearchitects.com

Project
WEST NEWTON RUTLAND APARTMENTS

Title
EXTERIOR FRONT RAILING DETAIL

Scale
AS NOTED

Project No.
16015

Drawing Reference
A300

Date
03/10/2020

Sheet No.

**SKA
40A
[ASI-021]**

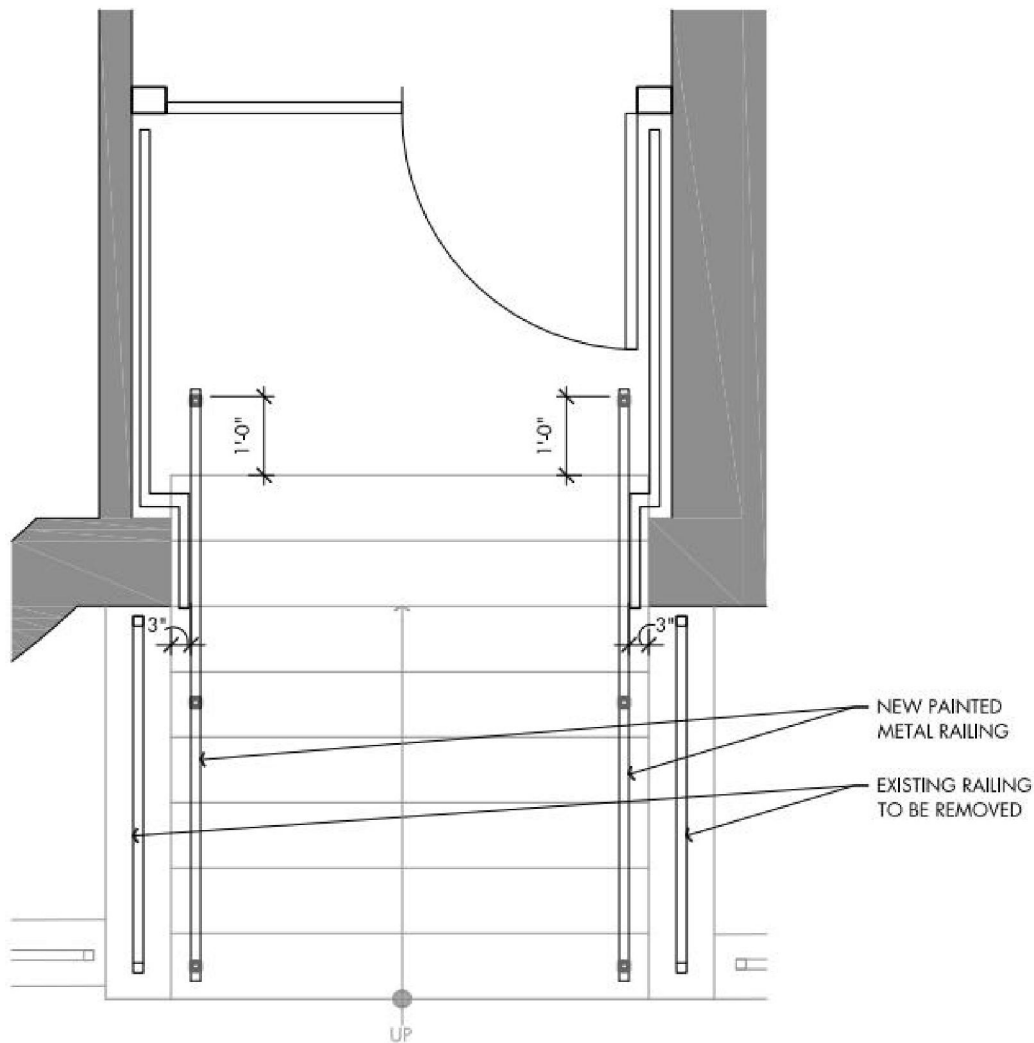

**DAVIS
SQUARE**
ARCHITECTS

240A Elm St
Somerville, MA 02144
617 628 5700
www.davisquarearchitects.com

Project
WEST NEWTON RUTLAND APARTMENTS

Title
EXTERIOR FRONT RAILING - TYPICAL PLAN

Scale
1/2" = 1'-0"

Project No.
16015

Drawing Reference

Date
03/10/2020

Sheet No.

**SKA-
40B**
(ASI 021)

G:\SKA\SKA\16015-WNR_SKA-40.dwg

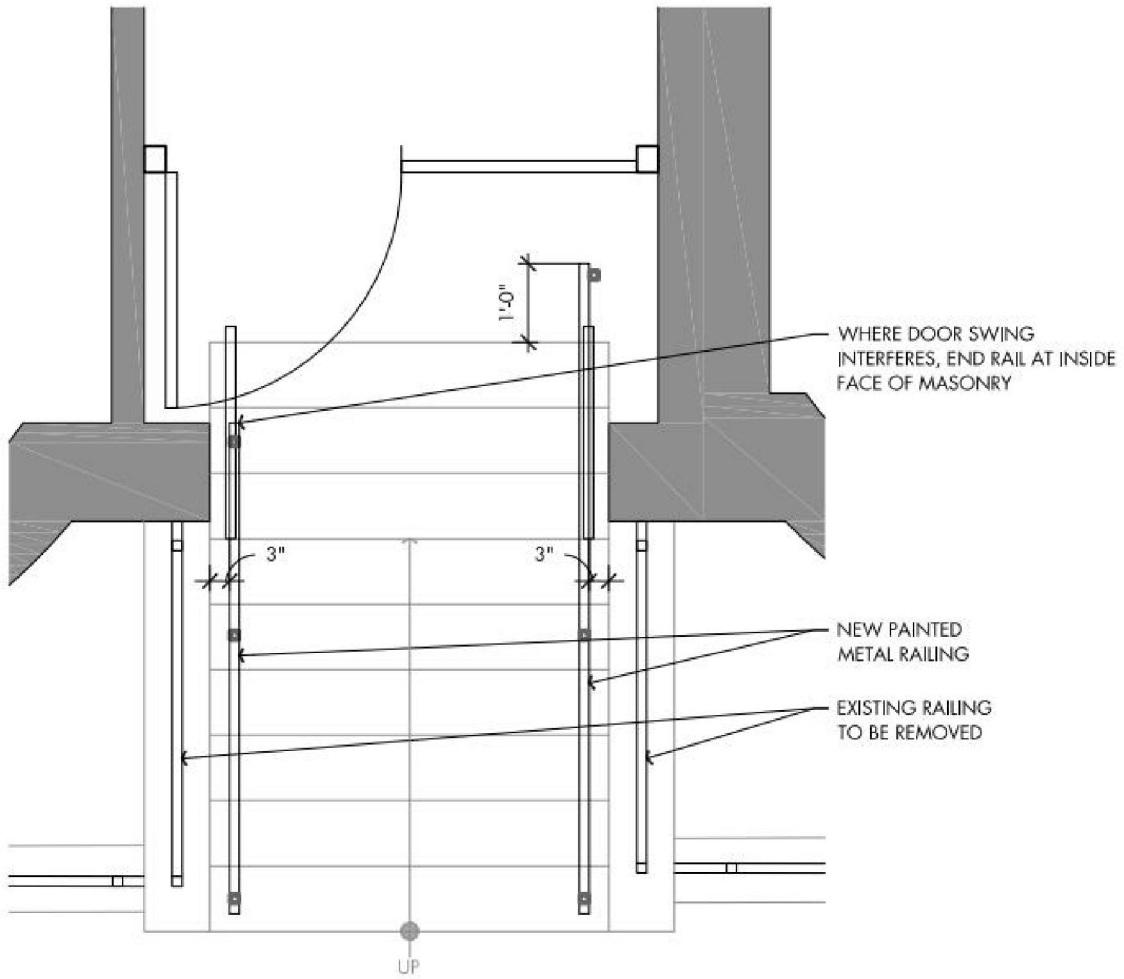

**DAVIS
SQUARE**
ARCHITECTS

240A Elm St
Somerville, MA 02144
617 628 5700
www.davisquarearchitects.com

Project		WEST NEWTON RUTLAND APARTMENTS		Sheet No.
Title		EXTERIOR FRONT RAILING - PLAN AT SHORT TOP LANDING		SKA-40C (ASI 021)
Drawing Reference				
Scale	Project No.	Date		
1/2"=1'-0"	16015	03/10/2020		

G:\SKA\SKA\16015-WNR_SKA-40.dwg

STRONGCOTE SC-11 PRODUCT DATA SHEETS



STRONGWALL INDUSTRIES, INC.

STRONGCOTE SC-111

Pedestrian Grade Traffic Deck Membrane System Product Data Sheet

Product Description

SC-111 is a breathable coating system. It can be installed in both interior and exterior pedestrian traffic areas. It is suitable for all masonry surfaces including cast in place and precast concrete. This two-part system is comprised of a liquid latex polymer containing migratory corrosion inhibitors and special anti-slip aggregate for skid resistance. Since the non-skid aggregate is contained in the mix, there is no need for sand broadcasting common with most traffic membranes. Furthermore, inclusion of the aggregate provides a more uniform wearing surface and longevity to the coating system.

Yield and Packaging

5-gallons of liquid packaged in a 6-gallon pail and two 55lbs bags of powder form one unit.

Unit yield: 600 sq. ft at 25 mils

Note: Minimum two coat required for the system

Shelf Life

One year.

Storage Conditions

Indoors, in a dry location, at temperatures not exceeding 90° F or lower than 35 ° F

Typical Physical Properties at 75°F (24°C)

Adhesion ASTM C-882, Type 1	515 psi
Static Coefficient of Friction ASTM C 1028.....	(Dry) 0.89
	(Wet) 0.60
Flammable Properties ASTM E84	Flame spread - 4
	Smoke Density - 0
Fire Resistance UL 790	Complies as Class A
Freeze-Thaw Resistance – 50 Cycles ...no scaling/peeling/flaking (Concrete cylinders immersed for 8 hrs in coated salt water solution followed by 16 hrs of freezing)	
Water Absorption Weight gain of 4" coated concrete cube after 21 days water immersion (CMCH)	<2%
Water Vapor Permeability ASTM E96	99.7 grams/sq. meter/24 hrs. or 14.3 perms
Weathering ASTM G23	No visible degradation
(Method1/Procedure; 60 cycles)	

Where to use

SC-111 should be applied as a protection system for concrete structures such as balconies, pools, decks, train passenger platforms, stadium walkways and aisles, water storage tank covers, highway median dividers, and noise barriers.

Advantages

1. Low water permeability that mask against water and salt penetration
2. High water vapor transmission that eliminates freeze/thaw damage.
3. Breathability allows for slab on grade, split slab and metal pan applications.
4. Contains migratory corrosion inhibitors that suppress rebar corrosion.
5. Provides excellent traction in both wet and dry conditions
6. Non-flammable, Class A, zero VOC, non toxic and odorless
7. Excellent UV resistance.
8. LEED (Leadership in Energy and Environmental Design.) Credit Points may be available under 5 different Classifications.
9. Does not contain chemicals targeted by Green Seal Standard GS-11 and LEED-CS as unacceptable.

Overview of Application Procedures

Crack Treatment Component

EM-100-N, a rubber emulsion, packaged in 5-gallon pails.
Mixing Ratio: Apply directly from pail
Yield: 800 lineal ft at 50 mils wet at 2" wide per 5-gal pail

Traffic-bearing Component

Strongcote #3 Liquid, a latex vinyl copolymer, 5 gallons of liquid packaged in a 6-gallon pail and Strongcote #3 Powder, an aggregate catalyst, packaged in 55-pound bags includes migratory corrosion inhibitors.
Mixing Ratio: Two 55-lb bags of Strongcote #3 Powder and one 5-gallon pail of Strongcote #3 Liquid form one unit.
Average Yield Per Unit: 600 sq. ft. @ 25 mils
This is always a two (2) 25mils coat system.

Optional Color Topping Component

Apply to improve cleanability and to enhance color quality
Resicolor #4 or Resiclear #6 homopolymer toppings, packaged in 5-gallon pails.
Mixing Ratio: Apply directly from pail.
Yield: 1000-1200 sq. ft. per 5-gallon pail
Mixing: Stir for 30 seconds.
Application: Apply on a clean, dry surface, using a short nap roller.

SKID RESISTANCE and CLEANABILITY

In general the more aggressive the finished surface the greater the coefficient of friction and corresponding skid resistance, the more difficult to clean. The smoother the finished texture the easier the surface is to clean, but there is a loss of skid resistant properties.

CHEMICAL RESISTANCE

See SWI Products Corp's., Chemical Resistance Guidelines for chemical resistance of a product or system, as well as the types of test performed:

- ASTM C868 Standard Test Method for Chemical Resistance of Protective Lining.
- ASTM C267 Standard Test Method for Chemical Resistance of Mortars, Grouts, and Monolithic Surfacing and Polymer Concretes.
- ASTM D1308 Standard Test Method for Effect of Household Chemicals on Clear and Pigmented Organic Finishes
- Strongwall Industries Inc. Proprietary Testing

Note: Chemical resistance is a functional test, usually limited to changes in weight or thickness measured in loss or gain and does not evaluate subject aesthetic issues. To determine aesthetic issues, SWI recommends testing the products or system in accordance with intended end use.

Cleaning

Cleaning and disinfecting compounds and cleaning techniques can affect the color, gloss, texture and performance of the system. As a precautionary step, SWI recommends that the end-user test their cleaning and disinfecting compounds on a sample or on a small, out of the way finished area, utilizing the intended cleaning technique prior to cleaning the entire surface area. If no deleterious effects are observed, the procedure can be continued. If the cleaning and disinfecting compounds or cleaning techniques damage the system, modification of the cleaning material or techniques will be required. Contact your Representative for additional information.

Cleaning Tools

Clean all tools with water immediately after use. If cured, mechanical means will be necessary.

First Aid

In case of skin contact, wash thoroughly with soap and water. For eye contact, flush immediately with plenty of water for at least 15 minutes. For respiratory problems, remove person to fresh air. Contact a physician. Keep container tightly closed. Keep out of reach of children, Not for internal consumption. For industrial use only.

Specification Assistance

Consult Strongwall Industries Incorporated for specification assistance and details. This consultation is highly recommended prior to specification.

Testing

The technical data contained herein is the result of tests made in manufacturer's laboratories or in independent laboratories using small scale equipment, following generally accepted trade practices. Although this information is believed to be true and accurate, the use of different equipment for testing under dissimilar conditions or the testing of samples produced under dissimilar conditions may develop substantially different results.

Strongwall Industries, Inc. 107 Chestnut Street, Ridgewood, NJ 07450 Phone: (201) 445-4633 Fax (201) 447-2317
Email: info@strongwall.com Website: www.strongwall.com

All information provided by Strongwall Industries concerning Strongwall products, including but not limited to, any recommendations and advice relating to the application and use of Strongwall products, is given in good faith based on Strongwall's current experience and knowledge of its product when properly stored, handled, and applied under normal conditions in accordance with Strongwall's instructions. In practice, the differences in materials, substrates, storage and handling conditions, actual site conditions and other factors outside of Strongwall's control are such that Strongwall assumes no liability for the provision of such information, advice, recommendations, or instructions related to its products, nor shall any legal relationship be created by or arise from the provision of such information, advice, recommendations, or instructions related to its products. The user of the Strongwall product(s) must test the product(s) for suitability for the intended application and purpose before proceeding with the full application of the product(s). Strongwall reserves the right to change the properties of its products without notice. All sales of Strongwall product(s) are subject to its current terms and conditions of sale which are available by calling 201-445-4633. Prior to each use of any Strongwall product, the user must always read and follow the instructions on the product's most current Product Data Sheet, product label, and Material Safety Data Sheet which are available by calling at 201-445-4633. Nothing contained in Strongwall materials relieves the user of the obligation to read and follow the instructions for each Strongwall product as set forth in the current Product Data Sheet application instructions, product label, and Material Safety Data Sheet prior to product use.

MATERIAL GUARANTEE

Strongwall Industries, Inc. (hereafter referred to as Strongwall) guarantees materials only for a period of 1 year from the date of installation, when applied to an approved substrate by an approved applicator in accordance with Strongwall's written specifications, application instructions, and Product Data Sheet. **STRONGWALL DISCLAIMS ANY OTHER GUARANTEE OR WARRANTY EXPRESS OR IMPLIED OF THE MATERIALS AND THIS GUARANTEE SHALL BE THE SOLE REMEDY OF ANY PERSON WHO PURCHASES OR USES THE MATERIALS.** This guarantee applies only to material defects and will not apply in instances where failure has been caused by substrate defects including improper preparation, structural movement or settlement. In addition, it will not cover vandalism, accidents, acts of God, ordinary wear or any other damage not associated with normal usage. Where the materials have been applied over a previous coated surface, guarantee is limited to adhesion of the materials to previous coating and does not guarantee adhesion of previous coating to substrate. This guarantee is valid only upon completion of the job, proper maintenance of all systems, payment in full to Strongwall and after the applicator and owner have affixed their signatures to the fully executed document to signify their acceptance of its terms and conditions and to release Strongwall of all claims and obligations other than those set forth in the above paragraph. A fully executed copy must be returned to Strongwall. In the event of any kind of failure, the owner will advise the approved applicator in writing. The applicator will make an inspection to determine the cause of such failure. Should materials failure occur, Strongwall will provide replacement of materials that may be required to correct deficiencies. There are no express agreements other than those set forth in the above paragraphs. Buyer understands and agrees that any and all warranties implied by the provisions of the Uniform Commercial Code are executed from this sale.

Strongwall Industries, Inc. 107 Chestnut Street, Ridgewood, NJ 07450 Phone: (201) 445-4633 Fax (201) 447-2317
Email: info@strongwall.com Website: www.strongwall.com

EXISTING CONDITION PHOTOGRAPHS

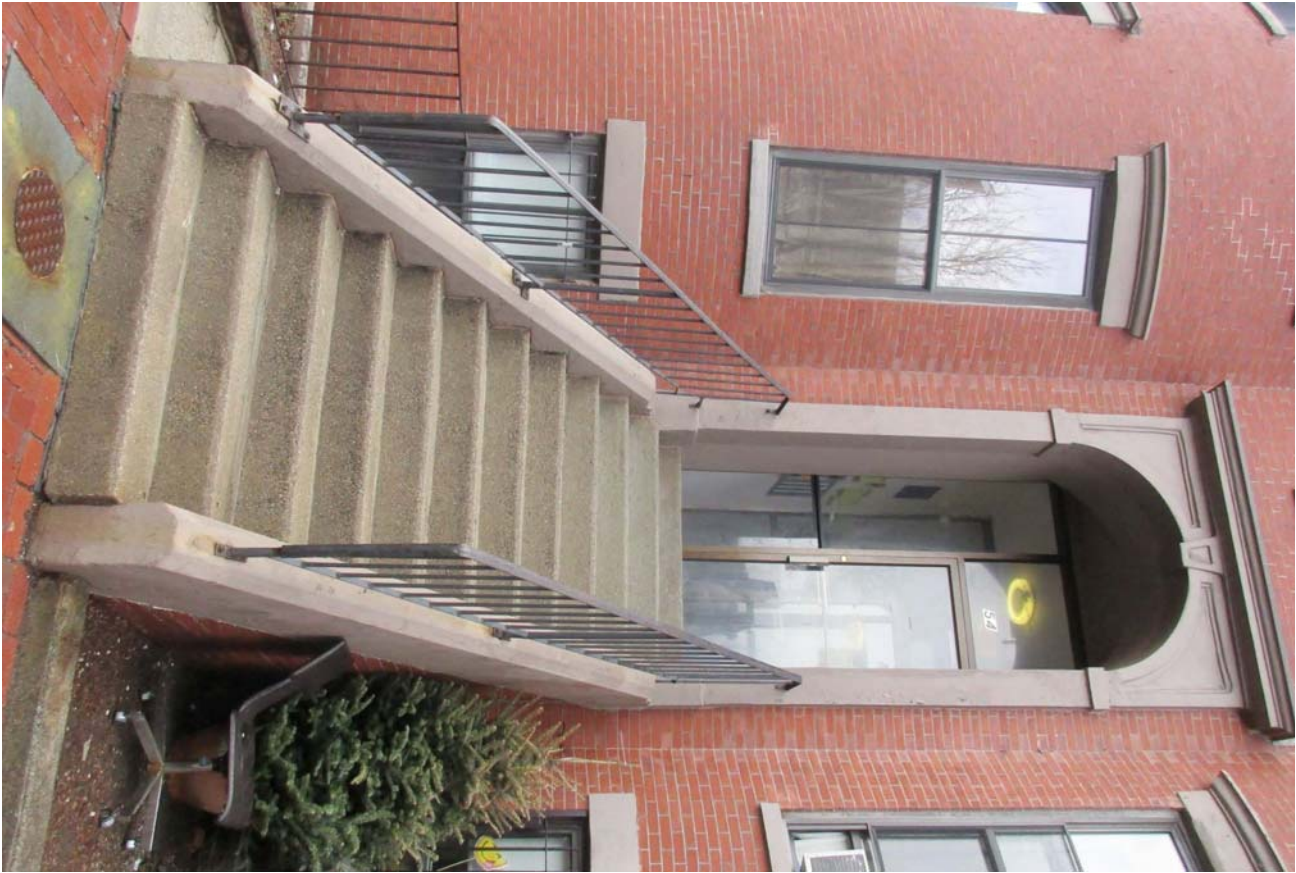

1. 54 West Newton Street

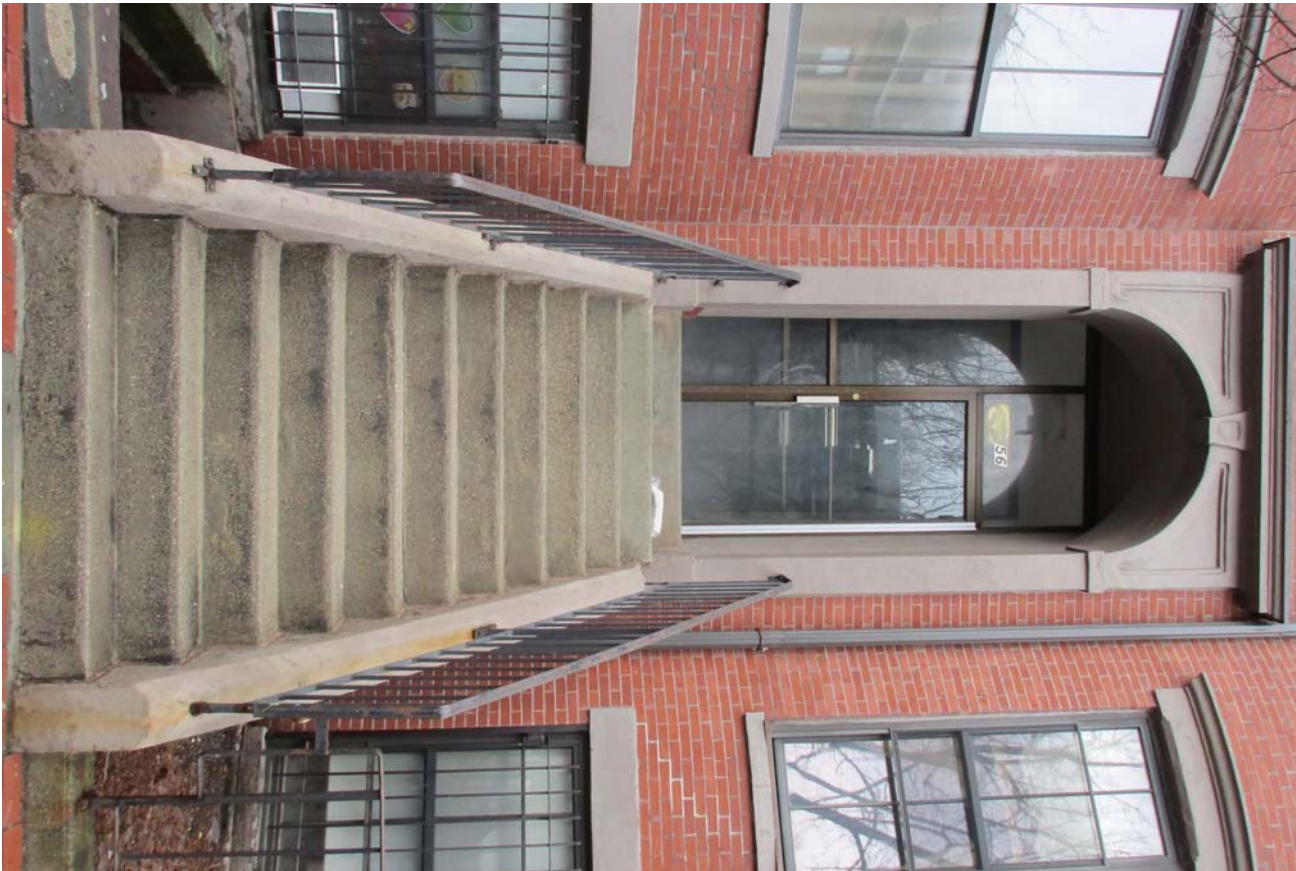

2. 56 West Newton Street

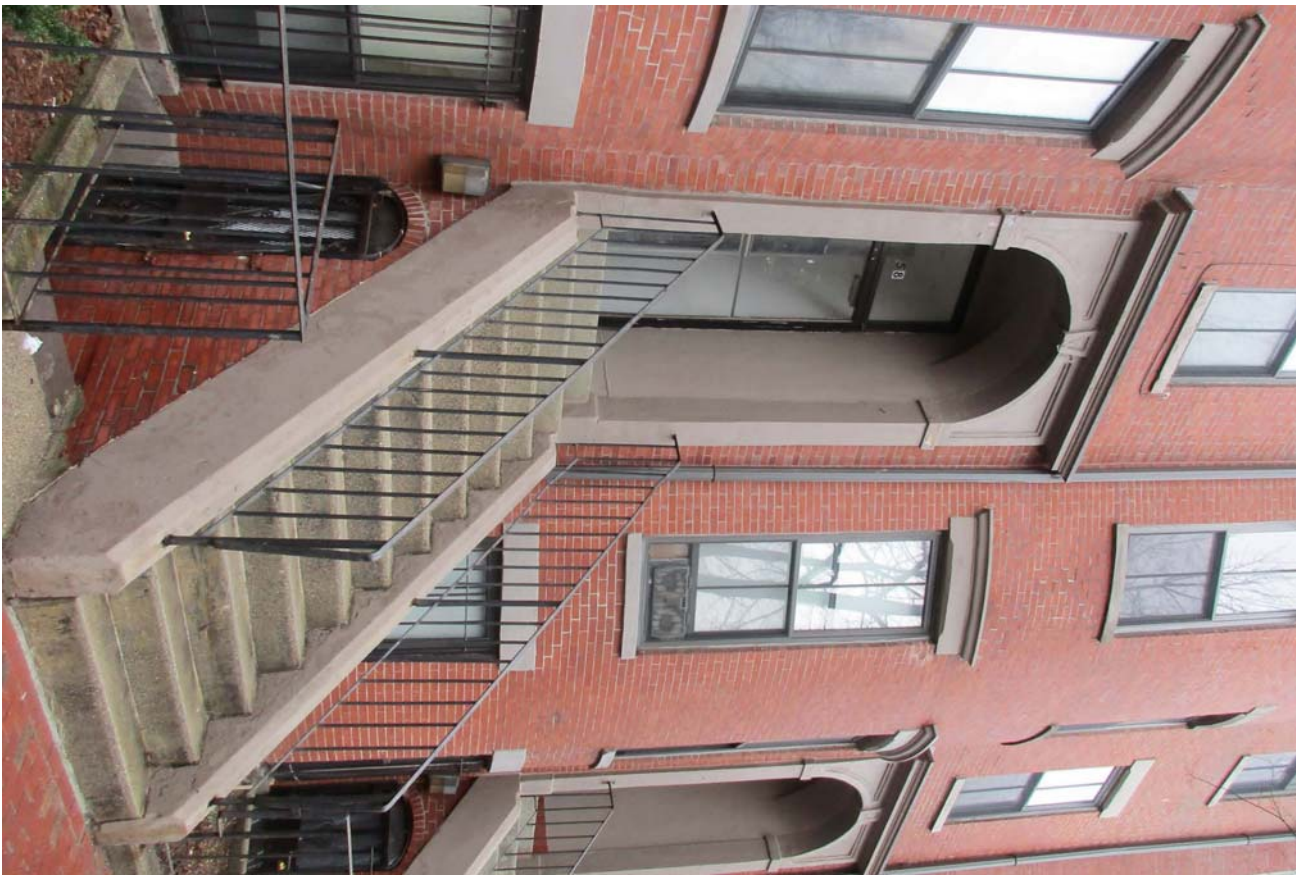

3. 58 West Newton Street

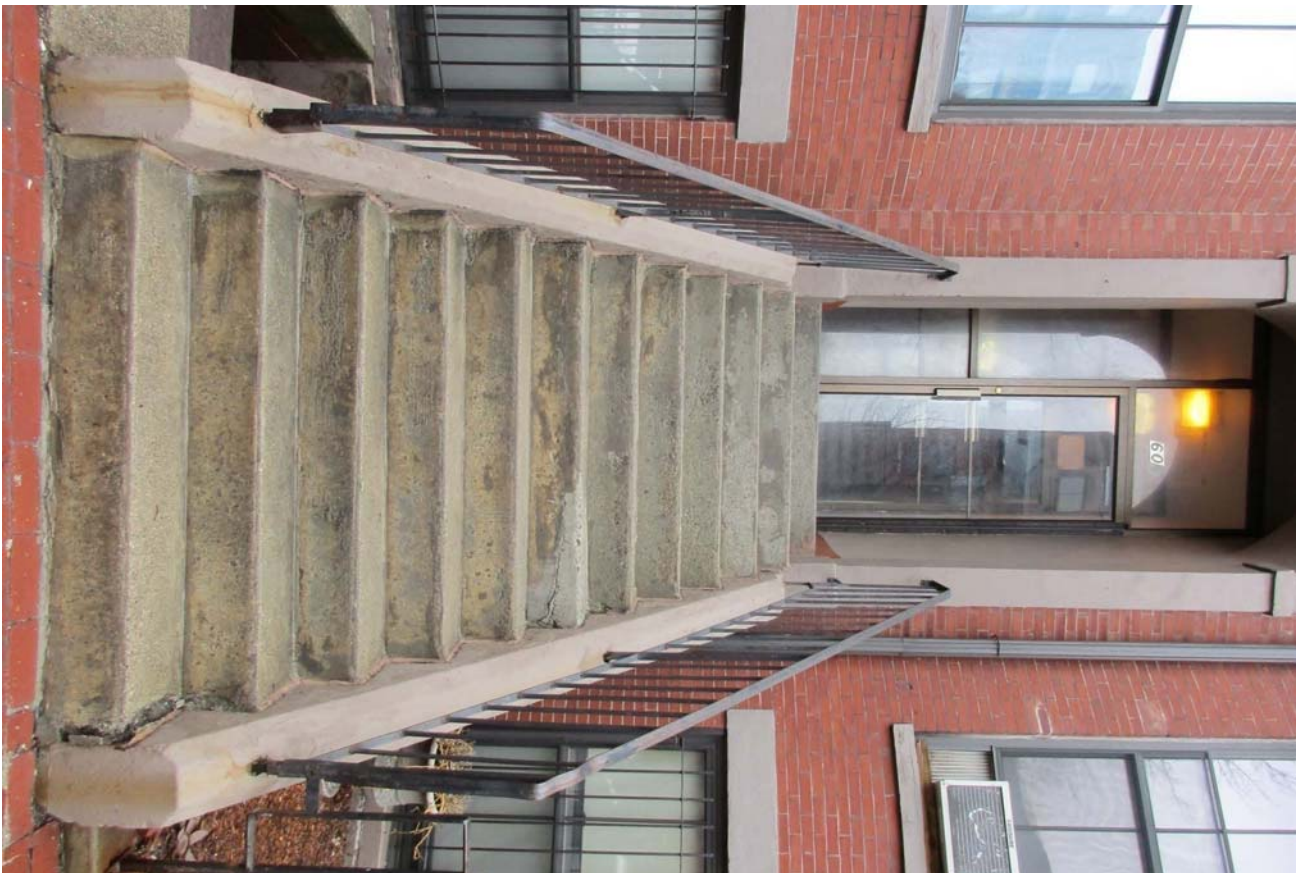

4. 60 West Newton Street



5. 62 West Newton Street



6. 64 West Newton Street



7. 66 West Newton Street



8. 66 West Newton Street



9. 68 West Newton Street



10. 70 West Newton Street



11. 72 West Newton Street



12. 72 West Newton Street



13. 74 West Newton Street



14. 76 West Newton Street



15. 78 West Newton Street



16. 80 West Newton Street



17. 82 West Newton Street



18. 84 West Newton Street



19. 86 West Newton Street



20. 88 West Newton Street



21. 90 West Newton Street



22. 92 West Newton Street



23. 94 West Newton Street



24. 96 West Newton Street



25. 98 West Newton Street



26. 100 West Newton Street



27. 102 West Newton Street