

WEST NEWTON STREET AND RUTLAND STREET APARTMENTS

54-102 WEST NEWTON STREET,
BOSTON (SOUTH END)

SOUTH END LANDMARK DISTRICT COMMISSION HEARING
PRESENTATION



EXTERIOR HANDRAIL DETAILS (SKA-40A, SKA-40B, SKA-40C)

EXISTING BRICK AND/OR STUCCO SIDEWALLS TO BE REPAIRED AFTER REMOVAL OF EXISTING HANDRAILS - DAMAGED BRICK TO BE REPLACED AND DAMAGED STUCCO TO BE PATCHED TO MATCH EXISTING

REMOVE EXISTING HANDRAIL AND BRACKETS FROM WALL

METAL 1-3/4" 'DIXIE' CAP RAIL WITH LAMBS TONGUE AT ENDS

1-1/4" SQ. METAL POSTS AT 4'-0" O.C. MAX. TYP. INSTALL POSTS 3" MIN FROM EDGES OF STAIR TREADS AND NOSINGS.

1/2" BALUSTERS AT 4" O.C. WELDED TO TOP AND BOTTOM RAILS.

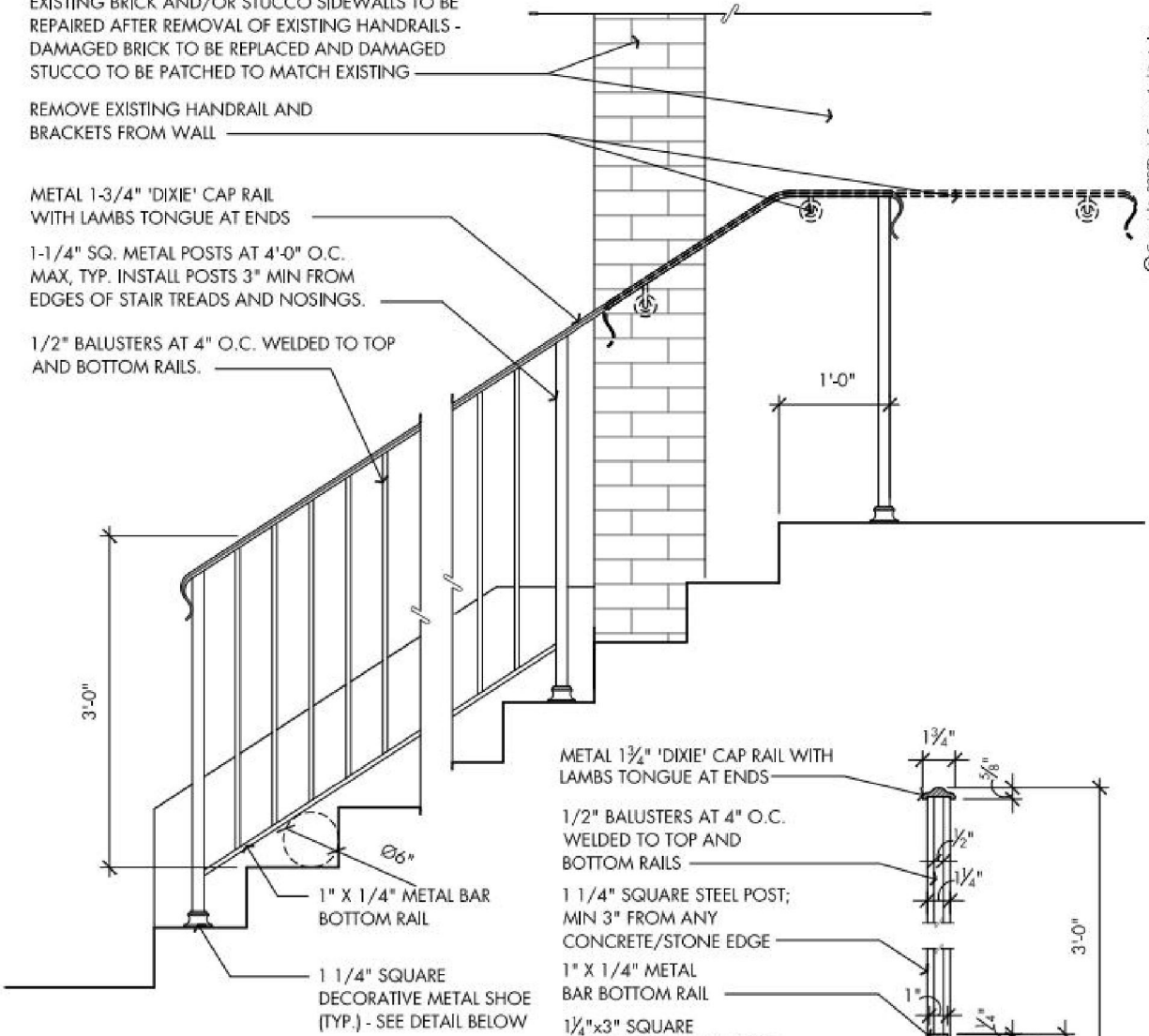

STAIR / RAILING SECTION DETAIL
SCALE: 3/4" = 1'-0"

METAL 1 3/4" 'DIXIE' CAP RAIL WITH LAMBS TONGUE AT ENDS

1/2" BALUSTERS AT 4" O.C. WELDED TO TOP AND BOTTOM RAILS

1 1/4" SQUARE STEEL POST; MIN 3" FROM ANY CONCRETE/STONE EDGE

1" X 1/4" METAL BAR BOTTOM RAIL

1 1/4" SQUARE DECORATIVE METAL SHOE

3/8" COMPRESSIBLE FILLER JOINT AT ALL SIDES, TYP EACH POST.

3/8" NON-SHRINK GROUT AT ALL SIDES AND BOTTOM OF COLUMN BASE, TYP. EACH POST

STAIR/STAIR LANDING

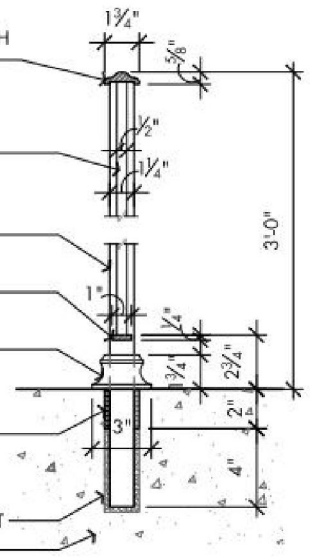

ENLARGED RAILING SECTION DETAIL
SCALE: 1 1/2" = 1'-0"



**DAVIS
SQUARE
ARCHITECTS**

240A Elm St
Somerville, MA 02144
617 628 5700
www.davisquarearchitects.com

Project WEST NEWTON RUTLAND APARTMENTS		Sheet No.
Title EXTERIOR FRONT RAILING DETAIL	Drawing Reference A300	SKA 40A [ASI-021]
Scale AS NOTED	Date 03/10/2020	
Project No. 16015		

I:\SKA\SKA\16015-WNR_SKA-40.dwg

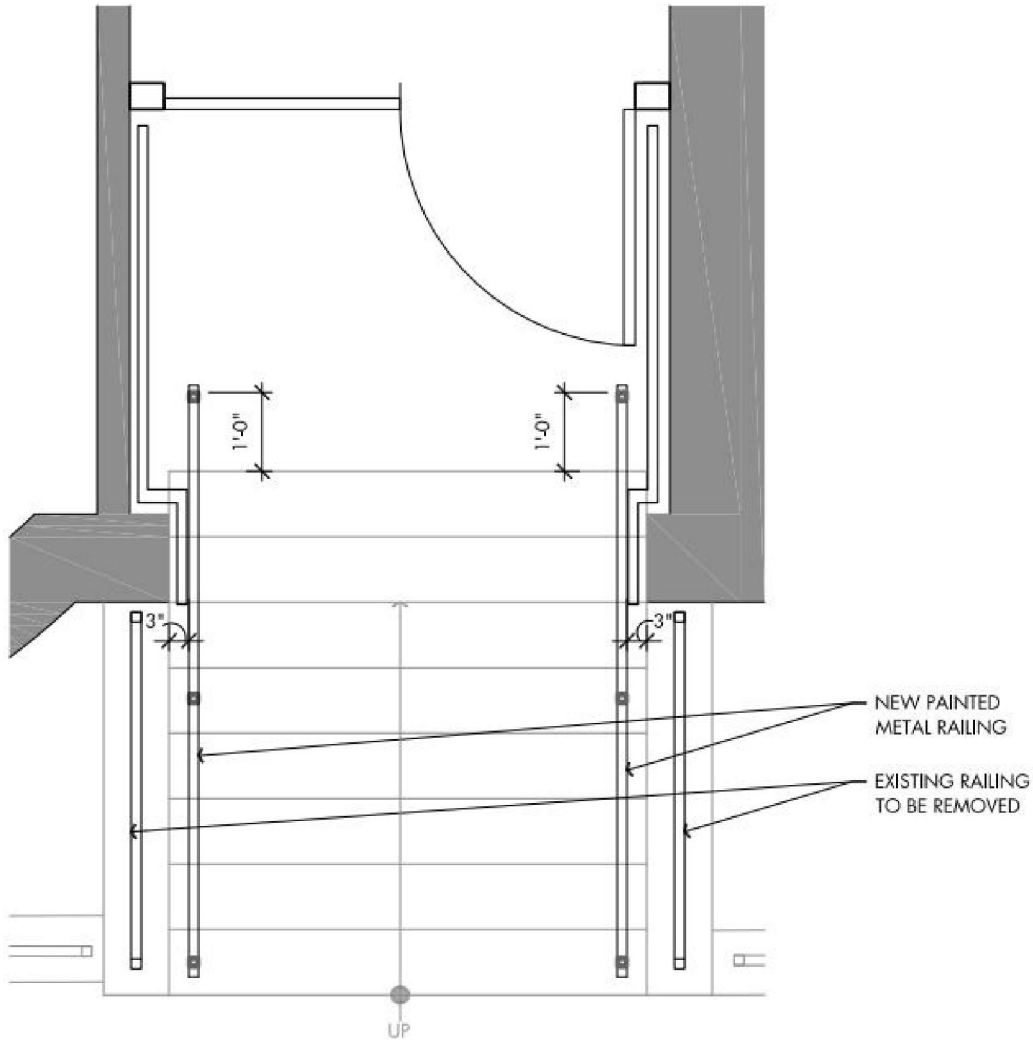

**DAVIS
SQUARE**
ARCHITECTS

240A Elm St
Somerville, MA 02144
617 628 5700
www.davisquarearchitects.com

Project WEST NEWTON RUTLAND APARTMENTS		Sheet No.
Title EXTERIOR FRONT RAILING - TYPICAL PLAN		SKA-40B (ASI 021)
Scale 1/2" = 1'-0"	Drawing Reference	
Project No. 16015	Date 03/10/2020	

G:\SKA\SKA\16015-WNR_SKA-40.dwg

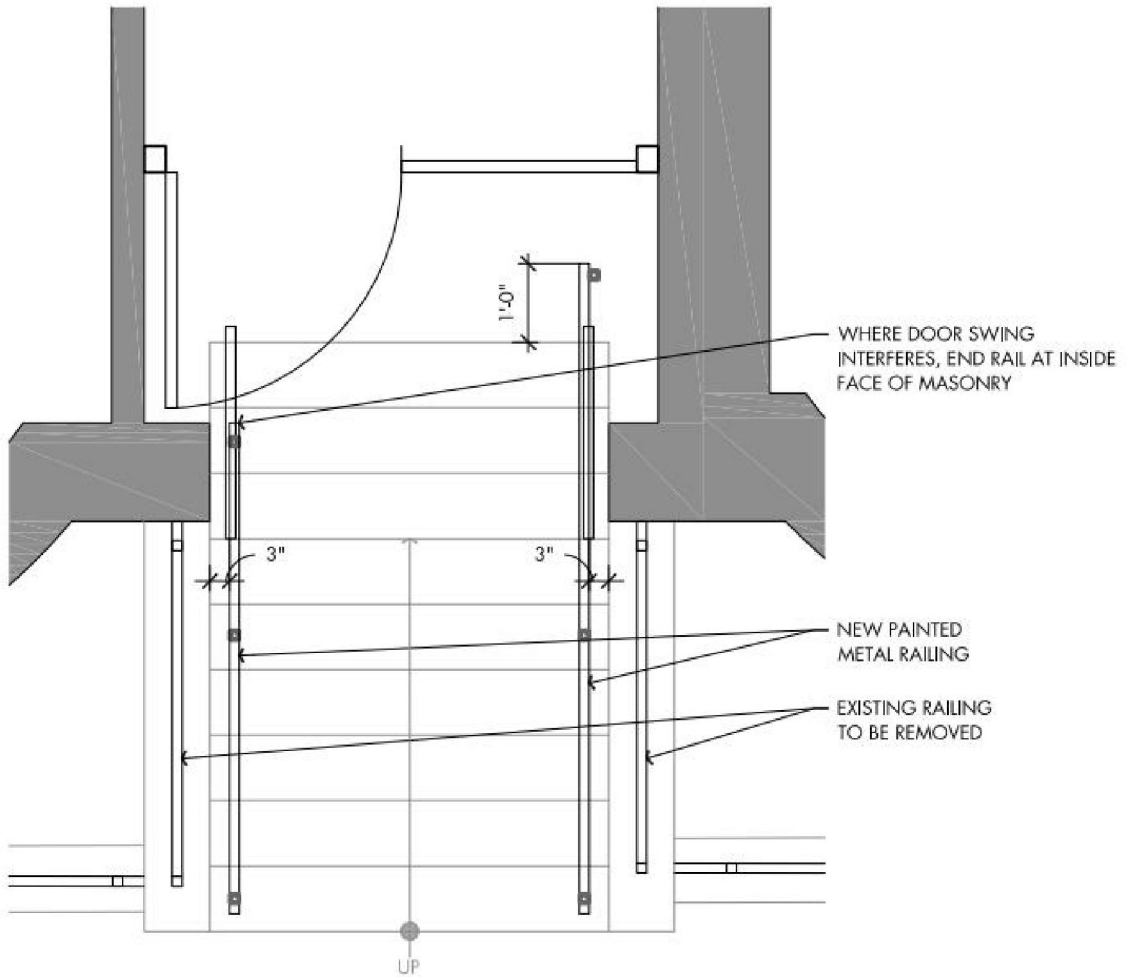

**DAVIS
SQUARE**
ARCHITECTS

240A Elm St
Somerville, MA 02144
617 628 5700
www.davisquarearchitects.com

Project	WEST NEWTON RUTLAND APARTMENTS		Sheet No.
Title	EXTERIOR FRONT RAILING - PLAN AT SHORT TOP LANDING	Drawing Reference	SKA-40C
Scale	1/2" = 1'-0"	Date	(ASI 021)
Project No.	16015		

G:\SKA\SKA\16015-WNR_SKA-40.dwg

EXISTING CONDITION PHOTOGRAPHS



1. 54 West Newton Street



2. 56 West Newton Street



3. 58 West Newton Street

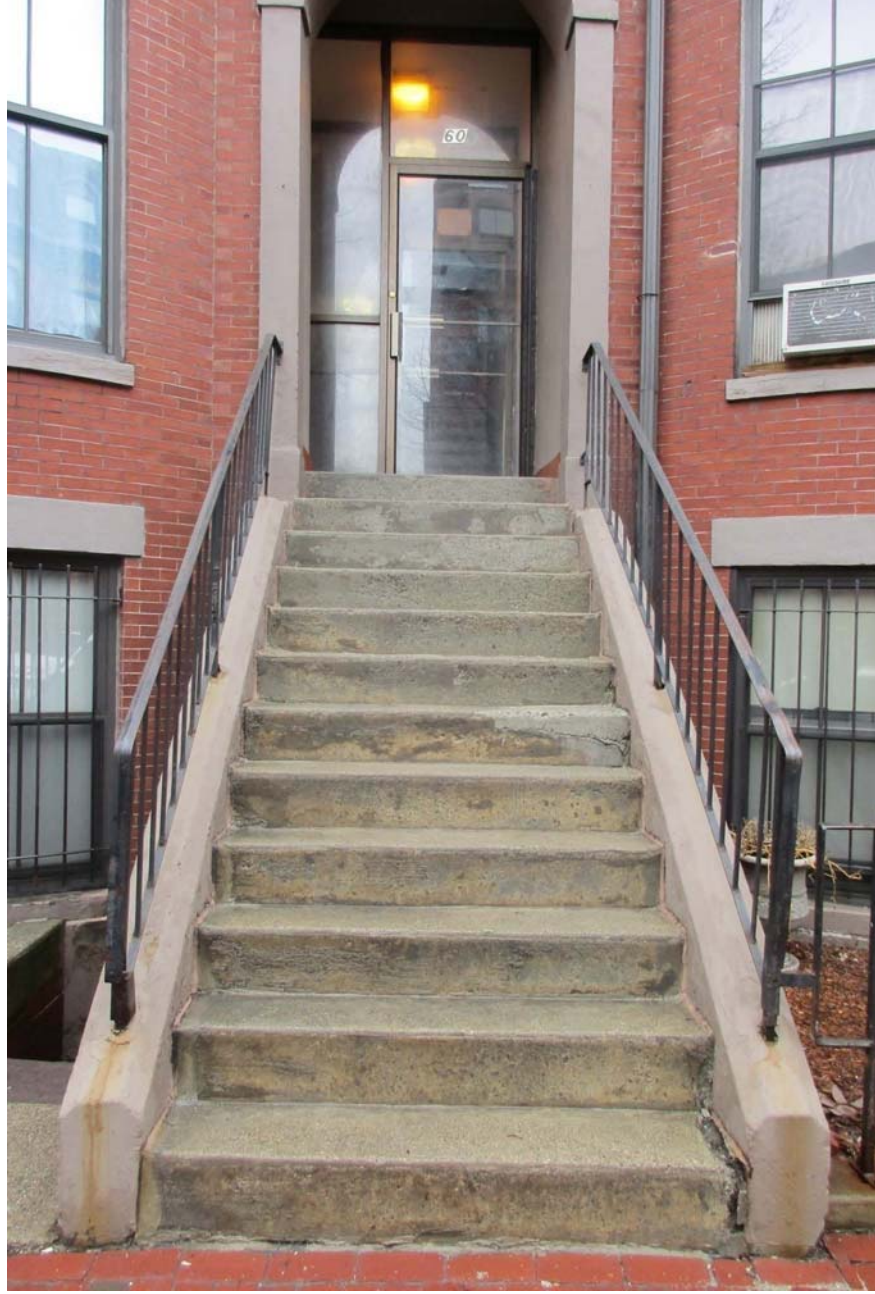

4. 60 West Newton Street



5. 62 West Newton Street



6. 64 West Newton Street



7. 66 West Newton Street



8. 66 West Newton Street



9. 68 West Newton Street



10. 70 West Newton Street



11. 72 West Newton Street



12. 72 West Newton Street



13. 74 West Newton Street



14. 76 West Newton Street



15. 78 West Newton Street



16. 80 West Newton Street



17. 82 West Newton Street



18. 84 West Newton Street



19. 86 West Newton Street



20. 88 West Newton Street



21. 90 West Newton Street



22. 92 West Newton Street



23. 94 West Newton Street



24. 96 West Newton Street



25. 98 West Newton Street



26. 100 West Newton Street



27. 102 West Newton Street