

RJO'CONNELL & ASSOCIATES, INC.

CIVIL ENGINEERS, SURVEYORS & LAND PLANNERS

80 Montvale Ave., Suite 201
phone 781-279-0180

Stoneham, MA 02180
fax 781-279-0173

February 16, 2021

March 3, 2021 (Revised)

Mr. Nicholas Moreno &
Members of the Boston Conservation Commission
Boston City Hall
1 City Hall Square
Room 709
Boston, MA 02201

**Re: Multifamily Residential Development
839 Saratoga Street
Boston, Massachusetts 02128**

Dear Mr. Moreno & Members of the Conservation Commission,

On behalf of 839 Saratoga St, LLC. (Applicant) and Mark W. Saviano (Owner), RJ O'Connell and Associates, Inc. (RJO) is respectfully submitting a Notice of Intent (NOI) Application for a Project which consists of redeveloping the property 839 Saratoga Street in East Boston, Massachusetts. More specifically, this project will include the demolition of the existing building, driveway, and parking area, and constructing a new multifamily building with an associated parking area. This NOI is being submitted in accordance with the requirements established under the Massachusetts Wetland Protection Act (MGL Chapter 131, Section 40), its Regulations (310 CMR 10.00), and the Boston Wetland Ordinance since the Site is within the 100-year floodplain.

As required by the above referenced regulations, we are notifying the abutters that this Application has been submitted to your offices and will be heard at an upcoming Public Hearing.

We look forward to presenting this Application to the Conservation Commission at one of the upcoming scheduled Public Hearings. In the meantime, please do not hesitate to contact me if you have any questions or concerns. I can be reached via email at brian.timm@rjoconnell.com or by calling 781-279-0180 ext. 142.

Respectfully,

RJO'CONNELL & ASSOCIATES



Brian W. Timm, PE
Associate Principal

cc: Richard Beliveau
MassDEP Northeast Regional Office

**Application for a
Notice of Intent**

**Multifamily Residential
Development @
839 Saratoga Street
East Boston, Massachusetts**

**Prepared for:
839 Saratoga St. LLC
PO Box 638
Winchester, Massachusetts 01890**

**Prepared by:
R.J. O'Connell & Associates, Inc.
80 Montvale Avenue, Suite 201
Stoneham, Massachusetts 02180**

**Date:
February 16, 2021
Revised: March 3, 2021**

TABLE OF CONTENTS

1.0 Notice of Intent Forms

- 1.1 Checklist for Filing a Notice of Intent with Boston Conservation Commission
- 1.2 MA DEP WPA Form 3 – Notice of Intent
- 1.3 Notice of Intent Wetland Fee Transmittal Form
- 1.4 City of Boston’s Notice of Intent Application Form
- 1.5 City of Boston Calculated Filing Fee Statement
- 1.6 Copies of Checks
- 1.7 City of Boston Extension Form
- 1.8 Climate Resiliency Checklist

2.0 Project Narrative

- 2.1 Executive Summary
- 2.2 Existing Site Conditions & Environmental Characteristics
- 2.3 Proposed Project
- 2.4 Protectable Wetland Resource Areas & Associated Impacts
- 2.5 Proposed Sedimentation & Erosion Control Mitigation Measures
- 2.6 Stormwater Management and Operation & Maintenance Plan
- 2.7 Resiliency
- 2.8 Summary

3.0 Figures

- 3.1 Figure 1 – USGS Locus Map
- 3.2 Figure 2 – FEMA Flood Insurance Rate Map
- 3.3 Figure 3 – NRCS Web Soil Survey Map
- 3.4 Figure 4 – ACEC Natural Heritage Map

4.0 Existing Site Photographs

5.0 Abutter Notification Information

- 5.1 Notification to Abutters (English & Spanish, Translation Cert. & Babel Card)
- 5.2 Affidavit of Service
- 5.3 Abutters List & Map

6.0 Stormwater Report (*Under separate cover*)

7.0 Plans

Existing Conditions Plan, Grading and Drainage Plan (*C-1*), Details (*C-2 & C-3*)

1.0 Forms

Checklist for Filing a Notice of Intent with Boston Conservation Commission

In order for the Boston Conservation Commission to effectively process your Notice of Intent, BCC requests that you complete the checklist below and include it with your submission. If you should need assistance please contact Commission Staff: 617-635-3850 (cc@boston.gov).

Please Submit the Following to the Conservation Commission:

- ✓ Two copies (a signed original and 1 copy) of a completed Notice of Intent (WPA Form 3)
- ✓ Two copies (a signed original and 1 copy) of a completed Boston Notice of Intent (Local Form)
- ✓ Two copies of plans (reduced to 11" X 17") in their final form with engineer's stamp affixed supporting calculations and other documentation necessary to completely describe the proposed work and mitigating measures. Plans must include existing conditions, the proposed project, erosion controls and mitigation measures, grading and spot elevations and all wetland resource areas and associated buffer zones. Some projects may require both an aerial view of the plans along with a profile view of plans depending on the scope of work.
- ✓ Two copies of an 8 ½" x 11" section of the [USGS quadrangle map](#) of the area, containing sufficient information for the Conservation Commission and the Department to locate the site of the work.
- ✓ (If applicable) Two copies the Federal Emergency Management Agency Flood Insurance Rate Map for the project site. FEMA Flood Maps: <https://msc.fema.gov/portal>.
- ✓ Two copies of the determination regarding the Natural Heritage and Endangered Species Program: Review Section C. Other Applicable Standards and Requirements of the Notice of Intent, page 4 of 8, pertaining to wildlife habitat. The Conservation Commission and the [Natural Heritage & Endangered Species Program](#) have the maps necessary to make this determination.
- ✓ (If applicable) Two hard copies of a Stormwater Report to document compliance with the Stormwater Management Standards per 310 CMR 10.05(6)(k)-(q), including associated drainage calculations for rooftops, parking lots, driveways, etc., for the required design storm events.
- ✓ (If applicable) A narrative detailing best management practices for stormwater management as set forth in the Stormwater Management Standards of the Massachusetts Department of Environmental Protection and any separate standards and guidelines prepared by the City and the Boston Water and Sewer Commission.
- ✓ (If applicable) Two hard copies of the Checklist for Stormwater Report
- ✓ Details of the stormwater management system, including: catch basins, oil separating tanks, detention basins, outfalls, sewer connections, etc.
- ✓ Any photographs related to the project representing the wetland resource areas.
- ✓ Two copies of a detailed project narrative describing the following: an overview of the entire project, the work proposed within wetland resource areas and/or buffer zones; how the performance standards specific to the wetland resource areas will be met (listing out each performance standard); a consideration of the effect that projected sea level rise, changes in storm intensity and frequency, and other consequences of climate change may have on the resource areas and proposed activities; construction equipment and material involved; and measures to protect wetland resource areas and mitigate impacts. The applicant shall also include narrative on how they plan to integrate climate change and adaptation planning considerations into their project to promote climate resilience to protect and promote Resource Area Values and functions into the future.
- ✓ Two copies of an Abutters List, Affidavit of Service and [Abutter Notification](#), filed concurrently with the Notice of Intent. Abutter notices shall be sent in both English and the second most commonly spoken language(s) in the neighborhood(s) where the project is proposed. Notices shall also include Babel notice cards for additional translation and language access services. [All abutters within 300' of the project](#)

Checklist for Filing a Notice of Intent with Boston Conservation Commission

[property line](#) must be notified including those in a neighboring municipality. In such an instance, a copy of the filing must also be sent to the local Conservation Commission of the neighboring municipality.
EXCEPTION: When work is in land under water bodies and waterways or on a tract of land greater than 50 acres, written notification must only be given to abutters within 300 feet of the “project site.”



Proposed First Floor Elevation is 5-feet above the 100-year flood plain. Discussed in report
Two copies of the BPDA Climate Resiliency Checklist (for new buildings). This can be completed online at <http://www.bostonplans.org/planning/planning-initiatives/article-37-green-building-guidelines>. Please print the pdf that you will receive via email after completion and include it in your submission.



Electronic copies. Documents may be submitted via email, or via an email link to downloadable documents.



To minimize the use of non-recyclable materials **please do not include vinyl or plastic binders, bindings, folders or covers with the filing.** Staples and binder clips are good choices.

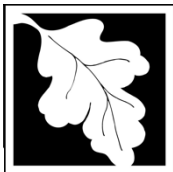

Massachusetts Department of Environmental Protection
Bureau of Resource Protection - Wetlands

WPA Form 3 – Notice of Intent

Massachusetts Wetlands Protection Act M.G.L. c. 131, §40

Provided by MassDEP:

MassDEP File Number

Document Transaction Number

City/Town

Important:

When filling out forms on the computer, use only the tab key to move your cursor - do not use the return key.



Note:
Before completing this form consult your local Conservation Commission regarding any municipal bylaw or ordinance.

A. General Information

1. Project Location (**Note:** electronic filers will click on button to locate project site):

839 Saratoga Street
a. Street Address

Boston
b. City/Town

02128
c. Zip Code

Latitude and Longitude:
42d 23' 05.08"
d. Latitude

71d 00' 50.61"
e. Longitude

01
f. Assessors Map/Plat Number

01025000
g. Parcel /Lot Number

2. Applicant:

Richard
a. First Name

Beliveau
b. Last Name

839 Saratoga St, LLC
c. Organization

PO Box 638
d. Street Address

Winchester
e. City/Town

MA
f. State

01890
g. Zip Code

(860) 559-0245
h. Phone Number

i. Fax Number

ricky@volnaycapital.com
j. Email Address

3. Property owner (required if different from applicant): Check if more than one owner

Mark
a. First Name

Saviano
b. Last Name

c. Organization

839A Saratoga Street
d. Street Address

Boston
e. City/Town

MA
f. State

02128
g. Zip Code

(617) 840-2579
h. Phone Number

i. Fax Number

j. Email address

4. Representative (if any):

Brian
a. First Name

Timm
b. Last Name

RJ O'Connell & Associates, Inc.
c. Company

80 Montvale Avenue
d. Street Address

Stoneham
e. City/Town

MA
f. State

02180
g. Zip Code

(781) 279-0180
x142

(781) 279-0173
i. Fax Number

brian.timm@rjoconnell.com
j. Email address

5. Total WPA Fee Paid (from NOI Wetland Fee Transmittal Form):

\$1,050
a. Total Fee Paid

\$512.50
b. State Fee Paid

\$1,500.00 (Max per BCC)
c. City/Town Fee Paid

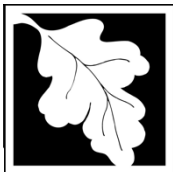

Massachusetts Department of Environmental Protection
Bureau of Resource Protection - Wetlands

WPA Form 3 – Notice of Intent

Massachusetts Wetlands Protection Act M.G.L. c. 131, §40

Provided by MassDEP:

MassDEP File Number

Document Transaction Number

City/Town

A. General Information (continued)

6. General Project Description:

Demolition of a residential building and construction of a new multi-family residential building and associated appurtenances.

7a. Project Type Checklist: (Limited Project Types see Section A. 7b.)

- 1. Single Family Home
- 2. Residential Subdivision
- 3. Commercial/Industrial
- 4. Dock/Pier
- 5. Utilities
- 6. Coastal engineering Structure
- 7. Agriculture (e.g., cranberries, forestry)
- 8. Transportation
- 9. Other **Multifamily Building**

7b. Is any portion of the proposed activity eligible to be treated as a limited project (including Ecological Restoration Limited Project) subject to 310 CMR 10.24 (coastal) or 310 CMR 10.53 (inland)?

1. Yes No If yes, describe which limited project applies to this project. (See 310 CMR 10.24 and 10.53 for a complete list and description of limited project types)

2. Limited Project Type

If the proposed activity is eligible to be treated as an Ecological Restoration Limited Project (310 CMR10.24(8), 310 CMR 10.53(4)), complete and attach Appendix A: Ecological Restoration Limited Project Checklist and Signed Certification.

8. Property recorded at the Registry of Deeds for:

Suffolk	
a. County	b. Certificate # (if registered land)
23771	323
c. Book	d. Page Number

B. Buffer Zone & Resource Area Impacts (temporary & permanent)

- 1. Buffer Zone Only – Check if the project is located only in the Buffer Zone of a Bordering Vegetated Wetland, Inland Bank, or Coastal Resource Area.
- 2. Inland Resource Areas (see 310 CMR 10.54-10.58; if not applicable, go to Section B.3, Coastal Resource Areas).

Check all that apply below. Attach narrative and any supporting documentation describing how the project will meet all performance standards for each of the resource areas altered, including standards requiring consideration of alternative project design or location.



Massachusetts Department of Environmental Protection
Bureau of Resource Protection - Wetlands

WPA Form 3 – Notice of Intent

Massachusetts Wetlands Protection Act M.G.L. c. 131, §40

Provided by MassDEP:

MassDEP File Number

Document Transaction Number

City/Town

B. Buffer Zone & Resource Area Impacts (temporary & permanent) (cont'd)

For all projects affecting other Resource Areas, please attach a narrative explaining how the resource area was delineated.

Resource Area	Size of Proposed Alteration	Proposed Replacement (if any)
a. <input type="checkbox"/> Bank	1. linear feet	2. linear feet
b. <input type="checkbox"/> Bordering Vegetated Wetland	1. square feet	2. square feet
c. <input type="checkbox"/> Land Under Waterbodies and Waterways	1. square feet	2. square feet
	3. cubic yards dredged	

Resource Area	Size of Proposed Alteration	Proposed Replacement (if any)
d. <input type="checkbox"/> Bordering Land Subject to Flooding	1. square feet	2. square feet
	3. cubic feet of flood storage lost	4. cubic feet replaced
e. <input type="checkbox"/> Isolated Land Subject to Flooding	1. square feet	
	2. cubic feet of flood storage lost	3. cubic feet replaced

- f. Riverfront Area
1. Name of Waterway (if available) - **specify coastal or inland**
2. Width of Riverfront Area (check one):
- 25 ft. - Designated Densely Developed Areas only
 - 100 ft. - New agricultural projects only
 - 200 ft. - All other projects

3. Total area of Riverfront Area on the site of the proposed project: _____ square feet

4. Proposed alteration of the Riverfront Area:

a. total square feet _____ b. square feet within 100 ft. _____ c. square feet between 100 ft. and 200 ft. _____

5. Has an alternatives analysis been done and is it attached to this NOI? Yes No

6. Was the lot where the activity is proposed created prior to August 1, 1996? Yes No

3. Coastal Resource Areas: (See 310 CMR 10.25-10.35)

Note: for coastal riverfront areas, please complete **Section B.2.f.** above.

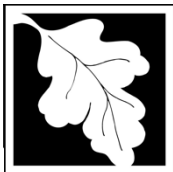

WPA Form 3 – Notice of Intent

Massachusetts Wetlands Protection Act M.G.L. c. 131, §40

Provided by MassDEP:

MassDEP File Number

Document Transaction Number

City/Town

B. Buffer Zone & Resource Area Impacts (temporary & permanent) (cont'd)

Check all that apply below. Attach narrative and supporting documentation describing how the project will meet all performance standards for each of the resource areas altered, including standards requiring consideration of alternative project design or location.

Online Users:
Include your document transaction number (provided on your receipt page) with all supplementary information you submit to the Department.

<u>Resource Area</u>	<u>Size of Proposed Alteration</u>	<u>Proposed Replacement (if any)</u>
a. <input type="checkbox"/> Designated Port Areas	Indicate size under Land Under the Ocean, below	
b. <input type="checkbox"/> Land Under the Ocean	_____	
	1. square feet	

	2. cubic yards dredged	
c. <input type="checkbox"/> Barrier Beach	Indicate size under Coastal Beaches and/or Coastal Dunes below	
d. <input type="checkbox"/> Coastal Beaches	_____	_____
	1. square feet	2. cubic yards beach nourishment
e. <input type="checkbox"/> Coastal Dunes	_____	_____
	1. square feet	2. cubic yards dune nourishment
	<u>Size of Proposed Alteration</u>	<u>Proposed Replacement (if any)</u>
f. <input type="checkbox"/> Coastal Banks	_____	
	1. linear feet	
g. <input type="checkbox"/> Rocky Intertidal Shores	_____	
	1. square feet	
h. <input type="checkbox"/> Salt Marshes	_____	_____
	1. square feet	2. sq ft restoration, rehab., creation
i. <input type="checkbox"/> Land Under Salt Ponds	_____	
	1. square feet	

	2. cubic yards dredged	
j. <input type="checkbox"/> Land Containing Shellfish	_____	
	1. square feet	
k. <input type="checkbox"/> Fish Runs	Indicate size under Coastal Banks, inland Bank, Land Under the Ocean, and/or inland Land Under Waterbodies and Waterways, above	

	1. cubic yards dredged	
l. <input checked="" type="checkbox"/> Land Subject to Coastal Storm Flowage	2,140 +/-	
	1. square feet	

4. Restoration/Enhancement
If the project is for the purpose of restoring or enhancing a wetland resource area in addition to the square footage that has been entered in Section B.2.b or B.3.h above, please enter the additional amount here.

_____ a. square feet of BVW _____ b. square feet of Salt Marsh

5. Project Involves Stream Crossings

_____ a. number of new stream crossings _____ b. number of replacement stream crossings

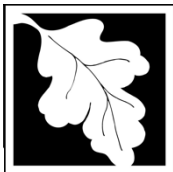

Massachusetts Department of Environmental Protection
Bureau of Resource Protection - Wetlands

WPA Form 3 – Notice of Intent

Massachusetts Wetlands Protection Act M.G.L. c. 131, §40

Provided by MassDEP:

MassDEP File Number

Document Transaction Number

City/Town

C. Other Applicable Standards and Requirements

- This is a proposal for an Ecological Restoration Limited Project. Skip Section C and complete Appendix A: Ecological Restoration Limited Project Checklists – Required Actions (310 CMR 10.11).

Streamlined Massachusetts Endangered Species Act/Wetlands Protection Act Review

1. Is any portion of the proposed project located in **Estimated Habitat of Rare Wildlife** as indicated on the most recent Estimated Habitat Map of State-Listed Rare Wetland Wildlife published by the Natural Heritage and Endangered Species Program (NHESP)? To view habitat maps, see the *Massachusetts Natural Heritage Atlas* or go to http://maps.massgis.state.ma.us/PRI_EST_HAB/viewer.htm.

- a. Yes No **If yes, include proof of mailing or hand delivery of NOI to:**

**Natural Heritage and Endangered Species Program
Division of Fisheries and Wildlife
1 Rabbit Hill Road
Westborough, MA 01581**

2017

b. Date of map

If yes, the project is also subject to Massachusetts Endangered Species Act (MESA) review (321 CMR 10.18). To qualify for a streamlined, 30-day, MESA/Wetlands Protection Act review, please complete Section C.1.c, and include requested materials with this Notice of Intent (NOI); *OR* complete Section C.2.f, if applicable. *If MESA supplemental information is not included with the NOI, by completing Section 1 of this form, the NHESP will require a separate MESA filing which may take up to 90 days to review (unless noted exceptions in Section 2 apply, see below).*

- c. Submit Supplemental Information for Endangered Species Review*

1. Percentage/acreage of property to be altered:

(a) within wetland Resource Area

percentage/acreage

(b) outside Resource Area

percentage/acreage

2. Assessor's Map or right-of-way plan of site

2. Project plans for entire project site, including wetland resource areas and areas outside of wetlands jurisdiction, showing existing and proposed conditions, existing and proposed tree/vegetation clearing line, and clearly demarcated limits of work **

(a) Project description (including description of impacts outside of wetland resource area & buffer zone)

(b) Photographs representative of the site

* Some projects **not** in Estimated Habitat may be located in Priority Habitat, and require NHESP review (see <https://www.mass.gov/endangered-species-act-mesa-regulatory-review>).

Priority Habitat includes habitat for state-listed plants and strictly upland species not protected by the Wetlands Protection Act.

** MESA projects may not be segmented (321 CMR 10.16). The applicant must disclose full development plans even if such plans are not required as part of the Notice of Intent process.

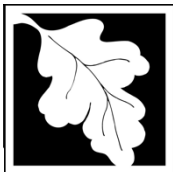

Massachusetts Department of Environmental Protection
Bureau of Resource Protection - Wetlands

WPA Form 3 – Notice of Intent

Massachusetts Wetlands Protection Act M.G.L. c. 131, §40

Provided by MassDEP:

MassDEP File Number

Document Transaction Number

City/Town

C. Other Applicable Standards and Requirements (cont'd)

- (c) MESA filing fee (fee information available at <https://www.mass.gov/how-to/how-to-file-for-a-mesa-project-review>).

Make check payable to "Commonwealth of Massachusetts - NHESP" and **mail to NHESP** at above address

Projects altering 10 or more acres of land, also submit:

- (d) Vegetation cover type map of site
- (e) Project plans showing Priority & Estimated Habitat boundaries
- (f) OR Check One of the Following

1. Project is exempt from MESA review.
Attach applicant letter indicating which MESA exemption applies. (See 321 CMR 10.14, <https://www.mass.gov/service-details/exemptions-from-review-for-projectsactivities-in-priority-habitat>; the NOI must still be sent to NHESP if the project is within estimated habitat pursuant to 310 CMR 10.37 and 10.59.)

2. Separate MESA review ongoing. a. NHESP Tracking # b. Date submitted to NHESP

3. Separate MESA review completed.
Include copy of NHESP "no Take" determination or valid Conservation & Management Permit with approved plan.

3. For coastal projects only, is any portion of the proposed project located below the mean high water line or in a fish run?

- a. Not applicable – project is in inland resource area only b. Yes No

If yes, include proof of mailing, hand delivery, or electronic delivery of NOI to either:

South Shore - Cohasset to Rhode Island border, and
the Cape & Islands:

North Shore - Hull to New Hampshire border:

Division of Marine Fisheries -
Southeast Marine Fisheries Station
Attn: Environmental Reviewer
836 South Rodney French Blvd.
New Bedford, MA 02744
Email: dmf.envreview-south@mass.gov

Division of Marine Fisheries -
North Shore Office
Attn: Environmental Reviewer
30 Emerson Avenue
Gloucester, MA 01930
Email: dmf.envreview-north@mass.gov

Also if yes, the project may require a Chapter 91 license. For coastal towns in the Northeast Region, please contact MassDEP's Boston Office. For coastal towns in the Southeast Region, please contact MassDEP's Southeast Regional Office.

- c. Is this an aquaculture project? d. Yes No

If yes, include a copy of the Division of Marine Fisheries Certification Letter (M.G.L. c. 130, § 57).

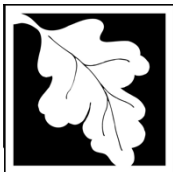

Massachusetts Department of Environmental Protection
Bureau of Resource Protection - Wetlands

WPA Form 3 – Notice of Intent

Massachusetts Wetlands Protection Act M.G.L. c. 131, §40

Provided by MassDEP:

MassDEP File Number

Document Transaction Number

City/Town

C. Other Applicable Standards and Requirements (cont'd)

Online Users:

Include your document transaction number (provided on your receipt page) with all supplementary information you submit to the Department.

4. Is any portion of the proposed project within an Area of Critical Environmental Concern (ACEC)?
- a. Yes No If yes, provide name of ACEC (see instructions to WPA Form 3 or MassDEP Website for ACEC locations). **Note:** electronic filers click on Website.
- b. ACEC
5. Is any portion of the proposed project within an area designated as an Outstanding Resource Water (ORW) as designated in the Massachusetts Surface Water Quality Standards, 314 CMR 4.00?
- a. Yes No
6. Is any portion of the site subject to a Wetlands Restriction Order under the Inland Wetlands Restriction Act (M.G.L. c. 131, § 40A) or the Coastal Wetlands Restriction Act (M.G.L. c. 130, § 105)?
- a. Yes No
7. Is this project subject to provisions of the MassDEP Stormwater Management Standards?
- a. Yes. Attach a copy of the Stormwater Report as required by the Stormwater Management Standards per 310 CMR 10.05(6)(k)-(q) and check if:
1. Applying for Low Impact Development (LID) site design credits (as described in Stormwater Management Handbook Vol. 2, Chapter 3)
 2. A portion of the site constitutes redevelopment
 3. Proprietary BMPs are included in the Stormwater Management System.
- b. No. Check why the project is exempt:
1. Single-family house
 2. Emergency road repair
 3. Small Residential Subdivision (less than or equal to 4 single-family houses or less than or equal to 4 units in multi-family housing project) with no discharge to Critical Areas.

D. Additional Information

- This is a proposal for an Ecological Restoration Limited Project. Skip Section D and complete Appendix A: Ecological Restoration Notice of Intent – Minimum Required Documents (310 CMR 10.12).

Applicants must include the following with this Notice of Intent (NOI). See instructions for details.

Online Users: Attach the document transaction number (provided on your receipt page) for any of the following information you submit to the Department.

1. USGS or other map of the area (along with a narrative description, if necessary) containing sufficient information for the Conservation Commission and the Department to locate the site. (Electronic filers may omit this item.)
2. Plans identifying the location of proposed activities (including activities proposed to serve as a Bordering Vegetated Wetland [BVW] replication area or other mitigating measure) relative to the boundaries of each affected resource area.

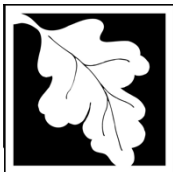

Massachusetts Department of Environmental Protection
Bureau of Resource Protection - Wetlands

WPA Form 3 – Notice of Intent

Massachusetts Wetlands Protection Act M.G.L. c. 131, §40

Provided by MassDEP:

MassDEP File Number

Document Transaction Number

City/Town

D. Additional Information (cont'd)

- 3. Identify the method for BVW and other resource area boundary delineations (MassDEP BVW Field Data Form(s), Determination of Applicability, Order of Resource Area Delineation, etc.), and attach documentation of the methodology.
- 4. List the titles and dates for all plans and other materials submitted with this NOI.
Existing Conditions Plan (EX-1) (Framingham Survey Consultants); Grading, Drainage, & Utility Plan (C-1); Details (C-2 & C-3)
 - a. Plan Title
 - RJ O'Connell & Associates, Inc. Brian Timm, PE
 - b. Prepared By
 - 2/16/2021 1"=10'
 - c. Signed and Stamped by
 - d. Final Revision Date
 - Stormwater Report and Operation and Maintenance Plan 2/16/2021
 - e. Scale
 - f. Additional Plan or Document Title
 - g. Date
- 5. If there is more than one property owner, please attach a list of these property owners not listed on this form.
- 6. Attach proof of mailing for Natural Heritage and Endangered Species Program, if needed.
- 7. Attach proof of mailing for Massachusetts Division of Marine Fisheries, if needed.
- 8. Attach NOI Wetland Fee Transmittal Form
- 9. Attach Stormwater Report, if needed.

E. Fees

- 1. Fee Exempt: No filing fee shall be assessed for projects of any city, town, county, or district of the Commonwealth, federally recognized Indian tribe housing authority, municipal housing authority, or the Massachusetts Bay Transportation Authority.

Applicants must submit the following information (in addition to pages 1 and 2 of the NOI Wetland Fee Transmittal Form) to confirm fee payment:

<u>10199</u>	<u>2/16/2021</u>
2. Municipal Check Number	3. Check date
<u>10907</u>	<u>2/16/2021</u>
4. State Check Number	5. Check date
<u>Volnay Capital, LLC</u>	
6. Payor name on check: First Name	7. Payor name on check: Last Name



Massachusetts Department of Environmental Protection
Bureau of Resource Protection - Wetlands

WPA Form 3 - Notice of Intent

Massachusetts Wetlands Protection Act M.G.L. c. 131, §40

Provided by MassDEP:

MassDEP File Number

Document Transaction Number

City/Town

F. Signatures and Submittal Requirements

I hereby certify under the penalties of perjury that the foregoing Notice of Intent and accompanying plans, documents, and supporting data are true and complete to the best of my knowledge. I understand that the Conservation Commission will place notification of this Notice in a local newspaper at the expense of the applicant in accordance with the wetlands regulations, 310 CMR 10.05(5)(a).

I further certify under penalties of perjury that all abutters were notified of this application, pursuant to the requirements of M.G.L. c. 131, § 40. Notice must be made by Certificate of Mailing or in writing by hand delivery or certified mail (return receipt requested) to all abutters within 100 feet of the property line of the project location.

Richard Beliveau

dotloop verified
02/12/21 3:41 PM EST
OQT3-Z9AD-EZNM-GL1U

1. Signature of Applicant

Mark W. Saviano

3. Signature of Property Owner (if different)

Bob [unclear]

5. Signature of Representative (if any)

2. Date

2-12-21

4. Date

2/16/2021

6. Date

For Conservation Commission:

Two copies of the completed Notice of Intent (Form 3), including supporting plans and documents, two copies of the NOI Wetland Fee Transmittal Form, and the city/town fee payment, to the Conservation Commission by certified mail or hand delivery.

For MassDEP:

One copy of the completed Notice of Intent (Form 3), including supporting plans and documents, one copy of the NOI Wetland Fee Transmittal Form, and a copy of the state fee payment to the MassDEP Regional Office (see Instructions) by certified mail or hand delivery.

Other:

If the applicant has checked the "yes" box in any part of Section C, Item 3, above, refer to that section and the Instructions for additional submittal requirements.

The original and copies must be sent simultaneously. Failure by the applicant to send copies in a timely manner may result in dismissal of the Notice of Intent.



Massachusetts Department of Environmental Protection
 Bureau of Resource Protection - Wetlands
NOI Wetland Fee Transmittal Form
 Massachusetts Wetlands Protection Act M.G.L. c. 131, §40

Important: When filling out forms on the computer, use only the tab key to move your cursor - do not use the return key.

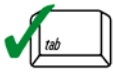

A. Applicant Information

1. Location of Project:

<u>839 Saratoga Street</u>	<u>Boston</u>
a. Street Address	b. City/Town
<u>10907</u>	<u>512.50</u>
c. Check number	d. Fee amount

2. Applicant Mailing Address:

<u>Richard</u>	<u>Beliveau</u>	
a. First Name	b. Last Name	
<u>839 Saratoga Street, LLC</u>		
c. Organization		
<u>PO Box 638</u>		
d. Mailing Address		
<u>Winchester</u>	<u>MA</u>	<u>01890</u>
e. City/Town	f. State	g. Zip Code
<u>(860) 559-0245</u>	<u>ricky@volnaycapital.com</u>	
h. Phone Number	i. Fax Number	
	j. Email Address	

3. Property Owner (if different):

<u>Mark</u>	<u>Saviano</u>	
a. First Name	b. Last Name	
<u></u>		
c. Organization		
<u>839A Saratoga Street</u>		
d. Mailing Address		
<u>Boston</u>	<u>MA</u>	<u>02128</u>
e. City/Town	f. State	g. Zip Code
<u>(617) 840-2579</u>	<u></u>	
h. Phone Number	i. Fax Number	
	j. Email Address	

B. Fees

Fee should be calculated using the following process & worksheet. **Please see Instructions before filling out worksheet.**

Step 1/Type of Activity: Describe each type of activity that will occur in wetland resource area and buffer zone.

Step 2/Number of Activities: Identify the number of each type of activity.

Step 3/Individual Activity Fee: Identify each activity fee from the six project categories listed in the instructions.

Step 4/Subtotal Activity Fee: Multiply the number of activities (identified in Step 2) times the fee per category (identified in Step 3) to reach a subtotal fee amount. Note: If any of these activities are in a Riverfront Area in addition to another Resource Area or the Buffer Zone, the fee per activity should be multiplied by 1.5 and then added to the subtotal amount.

Step 5/Total Project Fee: Determine the total project fee by adding the subtotal amounts from Step 4.

Step 6/Fee Payments: To calculate the state share of the fee, divide the total fee in half and subtract \$12.50. To calculate the city/town share of the fee, divide the total fee in half and add \$12.50.

To calculate filing fees, refer to the category fee list and examples in the instructions for filling out WPA Form 3 (Notice of Intent).



Massachusetts Department of Environmental Protection
 Bureau of Resource Protection - Wetlands
NOI Wetland Fee Transmittal Form
 Massachusetts Wetlands Protection Act M.G.L. c. 131, §40

B. Fees (continued)

Step 1/Type of Activity	Step 2/Number of Activities	Step 3/Individual Activity Fee	Step 4/Subtotal Activity Fee
Category 3 (b)	1	\$1,050	\$1,050
_____	_____	_____	_____
_____	_____	_____	_____
_____	_____	_____	_____
_____	_____	_____	_____
_____	_____	_____	_____
_____	_____	_____	_____
_____	_____	_____	_____
_____	_____	_____	_____
Step 5/Total Project Fee:			\$1,050

Step 6/Fee Payments:

Total Project Fee:	\$1,050
State share of filing Fee:	a. Total Fee from Step 5 \$512.50
City/Town share of filing Fee:	b. 1/2 Total Fee less \$12.50 \$1,500.00 (Max per BCC)

C. Submittal Requirements

- a.) Complete pages 1 and 2 and send with a check or money order for the state share of the fee, payable to the Commonwealth of Massachusetts.

Department of Environmental Protection
 Box 4062
 Boston, MA 02211

- b.) **To the Conservation Commission:** Send the Notice of Intent or Abbreviated Notice of Intent; a **copy** of this form; and the city/town fee payment.

To MassDEP Regional Office (see Instructions): Send a copy of the Notice of Intent or Abbreviated Notice of Intent; a **copy** of this form; and a **copy** of the state fee payment. (E-filers of Notices of Intent may submit these electronically.)



A. GENERAL INFORMATION

1. Project Location

<u>839 Saratoga Street</u>	<u>Boston</u>	<u>02128</u>
a. Street Address	b. City/Town	c. Zip Code
<u>01</u>	<u>01025000</u>	
f. Assessors Map/Plat Number	g. Parcel /Lot Number	

2. Applicant

<u>Richard</u>	<u>Beliveau</u>	<u>839 Saratoga St, LLC</u>
a. First Name	b. Last Name	c. Company
<u>PO Box 638</u>		
d. Mailing Address		
<u>Winchester</u>	<u>MA</u>	<u>01890</u>
e. City/Town	f. State	g. Zip Code
<u>(860) 559-0245</u>		<u>ricky@volnaycapital.com</u>
h. Phone Number	i. Fax Number	j. Email address

3. Property Owner

<u>Mark</u>	<u>Saviano</u>	
a. First Name	b. Last Name	c. Company
<u>839A Saratoga Street</u>		
d. Mailing Address		
<u>Boston</u>	<u>MA</u>	<u>02128</u>
e. City/Town	f. State	g. Zip Code
<u>(617) 840-2579</u>		
h. Phone Number	i. Fax Number	j. Email address

Check if more than one owner

(If there is more than one property owner, please attach a list of these property owners to this form.)

4. Representative (if any)

<u>Brian</u>	<u>Timm</u>	<u>RJ O'Connell and Associates, Inc.</u>
a. First Name	b. Last Name	c. Company
<u>80 Montvale Avenue</u>		
d. Mailing Address		
<u>Stoneham</u>	<u>MA</u>	<u>02180</u>
e. City/Town	f. State	g. Zip Code
<u>(781) 279-0180 x142</u>	<u>(781) 279-0173</u>	<u>brian.timm@rjoconnell.com</u>
h. Phone Number	i. Fax Number	j. Email address



5. Is any portion of the proposed project jurisdictional under the Massachusetts Wetlands Protection Act M.G.L. c. 131 §40?

Yes

No

If yes, please file the WPA Form 3 - Notice of Intent with this form

6. General Information

Demolition of an existing residential building and construction of a new multi-family residential building and associated parking and appurtenances.

7. Project Type Checklist

a. Single Family Home

b. Residential Subdivision

c. Limited Project Driveway Crossing

d. Commercial/Industrial

e. Dock/Pier

f. Utilities

g. Coastal Engineering Structure

h. Agriculture – cranberries, forestry

i. Transportation

j. Other
Multifamily Building

8. Property recorded at the Registry of Deeds

Suffolk

a. County

323

b. Page Number

23771

c. Book

d. Certificate # (if registered land)

9. Total Fee Paid

\$1,050

a. Total Fee Paid

\$512.50

b. State Fee Paid

\$550 per Local Bylaw

\$1,500 (Max. per BCC)

c. City Fee Paid

B. BUFFER ZONE & RESOURCE AREA IMPACTS

Buffer Zone Only - Is the project located only in the Buffer Zone of a resource area protected by the Boston Wetlands Ordinance?

Yes

No

1. Coastal Resource Areas



<u>Resource Area</u>	<u>Resource Area Size</u>	<u>Proposed Alteration*</u>	<u>Proposed Mitigation</u>
<input type="checkbox"/> Coastal Flood Resilience Zone	_____	_____	_____
	Square feet	Square feet	Square feet
<input type="checkbox"/> 25-foot Waterfront Area	_____	_____	_____
	Square feet	Square feet	Square feet
<input type="checkbox"/> 100-foot Salt Marsh Area	_____	_____	_____
	Square feet	Square feet	Square feet
<input type="checkbox"/> Riverfront Area	_____	_____	_____
	Square feet	Square feet	Square feet

2. Inland Resource Areas

<u>Resource Area</u>	<u>Resource Area Size</u>	<u>Proposed Alteration*</u>	<u>Proposed Mitigation</u>
<input type="checkbox"/> Inland Flood Resilience Zone	_____	_____	_____
	Square feet	Square feet	Square feet
<input type="checkbox"/> Isolated Wetlands	_____	_____	_____
	Square feet	Square feet	Square feet
<input type="checkbox"/> Vernal Pool	_____	_____	_____
	Square feet	Square feet	Square feet
<input type="checkbox"/> Vernal Pool Habitat (vernal pool + 100 ft. upland area)	_____	_____	_____
	Square feet	Square feet	Square feet
<input type="checkbox"/> 25-foot Waterfront Area	_____	_____	_____
	Square feet	Square feet	Square feet
<input type="checkbox"/> Riverfront Area	_____	_____	_____
	Square feet	Square feet	Square feet

C. OTHER APPLICABLE STANDARDS & REQUIREMENTS

1. What other permits, variances, or approvals are required for the proposed activity described herein and what is the status of such permits, variances, or approvals?

- _____
- BWSC Site Plan Approval (Pending)
- _____
- Public Improvement Commission Review (Pending)
- _____
- ERT from ISD for Permit Number 016403
- _____
- _____
- _____



2. Is any portion of the proposed project located in Estimated Habitat of Rare Wildlife as indicated on the most recent Estimated Habitat Map of State-Listed Rare Wetland Wildlife published by the Natural Heritage and Endangered Species Program (NHESP)? To view habitat maps, see the Massachusetts Natural Heritage Atlas or go to <http://www.mass.gov/dfwele/dfw/nhosp/nhregmap.htm>.

Yes

No

If yes, the project is subject to Massachusetts Endangered Species Act (MESA) review (321 CMR 10.18).

A. Submit Supplemental Information for Endangered Species Review

Percentage/acreage of property to be altered:

(1) within wetland Resource Area

_____ percentage/acreage

(2) outside Resource Area

_____ percentage/acreage

Assessor's Map or right-of-way plan of site

3. Is any portion of the proposed project within an Area of Critical Environmental Concern?

Yes

No

If yes, provide the name of the ACEC: _____

4. Is the proposed project subject to provisions of the Massachusetts Stormwater Management Standards?

Yes. Attach a copy of the Stormwater Checklist & Stormwater Report as required.

Applying for a Low Impact Development (LID) site design credits

A portion of the site constitutes redevelopment

Proprietary BMPs are included in the Stormwater Management System

No. Check below & include a narrative as to why the project is exempt

Single-family house

Emergency road repair

Small Residential Subdivision (less than or equal to 4 single family houses or less than or equal to 4 units in a multifamily housing projects) with no discharge to Critical Areas

5. Is the proposed project subject to Boston Water and Sewer Commission Review?

Yes

No



City of Boston
Environment

NOTICE OF INTENT APPLICATION FORM

Boston Wetlands Ordinance

City of Boston Code, Ordinances, Chapter 7-1.4

Boston File Number

MassDEP File Number

D. SIGNATURES AND SUBMITTAL REQUIREMENTS

I hereby certify under the penalties of perjury that the foregoing Notice of Intent and accompanying plans, documents, and supporting data are true and complete to the best of my knowledge. I understand that the Conservation Commission will place notification of this Notice in a local newspaper at the expense of the applicant in accordance with the Wetlands Protection Ordinance.

Richard Beliveau

dotloop verified
02/12/21 3:42 PM EST
ATQP-SJL-G79H-LSUX

Signature of Applicant

Date

Mark W. Samians

2-12-21

Signature of Property Owner (if different)

Date

Brian...

2/16/2021

Signature of Representative (if any)

Date

Calculated Filing Fee Statement for the City of Boston's Fee under the WPA

The Applicant is seeking an Order of Conditions from the City of Boston Conservation Commission to construct a multi-family residence at 839 Saratoga Street in Boston, MA. The Wetland Resource Area applicable to this Site is Land Subject to Coastal Storm Flowage. Proposed activities are included within Category 3 (b) (*each building (for development) including site*) under the Wetland Filing Fee Calculation Worksheet.

The fee for Category 3 (b) is as follows:

City of Boston Fee:

*The City of Boston does not collect the Municipal Portion of the WPA State Filing Fee. The City of Boston has its own fee structure requirements for a project submitted under the WPA:

$$\begin{aligned} &= 0.075\% \text{ of Fair Cost Provided for the Project} \\ &= (0.00075) \times (\$2,000,000.00 \text{ (per information provided by Applicant)}) \\ &\text{City of Boston Fee for WPA Portion of the Application} = \$1,500.00 \end{aligned}$$

Check Payable to: City of Boston for \$1,500.00



City of Boston
Environment



City of Boston
Mayor Martin J. Walsh

EXTENSION FORM

The undersigned hereby allows the **Boston Conservation Commission** an extension of time, beyond the statutory limit, to review an application or issue a final decision under the Massachusetts Wetlands Protection Act, M.G.L. Chapter 131, Section 40, and the Boston Wetlands Ordinance, Boston City Code, Ordinances, Chapter 7-1.4d during the state of emergency declared by the Governor on March 10, 2020.

Applicant:

Richard

Beliveau

839 Saratoga St, LLC

a. First Name

b. Last Name

c. Company

PO Box 638

d. Mailing Address

Winchester

MA

01890

e. City/Town

f. State

g. Zip Code

(860) 559-0245

ricky@volnaycapital.com

h. Phone Number

i. Fax Number

j. Email address

Signature of Applicant

02-16-2021

Date

Property Owner (if different):

Mark

Saviano

a. First Name

b. Last Name

c. Company

839A Saratoga Street

d. Mailing Address

Boston

MA

02128

e. City/Town

f. State

g. Zip Code

(617) 840-2579

h. Phone Number

i. Fax Number

j. Email address

Signature of Property Owner (if different)

Date

Applications will only be accepted when submitted with a properly executed Extension Form.

NOTE: Project filings should be prepared and submitted using the online [Climate Resiliency Checklist](#).

A.1 - Project Information

Project Name:	839 Saratoga Street		
Project Address:	839 Saratoga Street		
Project Address Additional:	Boston, Massachusetts 02128		
Filing Type (select)	<i>Initial (Notice of Intent Application)</i> <i>Design / Building Permit (prior to final design approval)</i> <i>Brian W. Timm, PE</i> <i>brian.timm@rjoconnell.com</i>		
Filing Contact	RJ O'Connell & Associates, Inc.		781.279-0180
Is MEPA approval required	No		

A.3 - Project Team

Owner / Developer:	839 Saratoga Street, LLC		
Architect:	Context Architects		
Engineer:	MEP: TE2 Engineering, Civil: RJ O'Connell & Associates		
Sustainability / LEED:			
Permitting:	RJ O'Connell & Associates / Context Architects		
Construction Management:	Unknown at Current Time		

A.3 - Project Description and Design Conditions

List the principal Building Uses:	Multifamily Residential
List the First Floor Uses:	Multifamily Residential; Mechanical Room; Covered Parking
List any Critical Site Infrastructure and or Building Uses:	N/A

Site and Building:

Site Area:	5,000 SF	Building Area:	3,300 +/- SF
Building Height:	50 Ft	Building Height:	4 Stories
Existing Site Elevation – Low:	14.2 Ft BCB	Existing Site Elevation – High:	21.7 Ft BCB
Proposed Site Elevation – Low:	13.8 Ft BCB	Proposed Site Elevation – High:	21.7 Ft BCB
Proposed First Floor Elevation:	21.6 Ft BCB	Below grade levels:	0 Stories

Article 37 Green Building:

LEED Version - Rating System :	NA (not subject to Art. 80)	LEED Certification:	
Proposed LEED rating:		Proposed LEED point score:	.

Building Envelope

When reporting R values, differentiate between R discontinuous and R continuous. For example, use “R13” to show R13 discontinuous and use R10c.i. to show R10 continuous. When reporting U value, report total assembly U value including supports and structural elements.

Roof:	(R)	Exposed Floor:	(R)
Foundation Wall:	(R)	Slab Edge (at or below grade):	(R)

Vertical Above-grade Assemblies (%’s are of total vertical area and together should total 100%):

Area of Opaque Curtain Wall & Spandrel Assembly:	(%)	Wall & Spandrel Assembly Value:	(U)
Area of Framed & Insulated / Standard Wall:	(%)	Wall Value	(R)
Area of Vision Window:	%	Window Glazing Assembly Value:	(U)
		Window Glazing SHGC:	(SHGC)
Area of Doors:	%	Door Assembly Value:	(U)

Energy Loads and Performance

For this filing – describe how energy loads & performance were determined

Project is applying HERS Rating to comply with the Energy Code			
Annual Electric:	(kWh)	Peak Electric:	125 (kW)
Annual Heating:	(MMbtu/hr)	Peak Heating:	266 (MMbtu)
Annual Cooling:	(Tons/hr)	Peak Cooling:	17 (Tons)
Energy Use - Below ASHRAE 90.1 - 2013:	%	Have the local utilities reviewed the building energy performance?:	Yes / no
Energy Use - Below Mass. Code:	%	Energy Use Intensity:	(kBtu/SF)

Back-up / Emergency Power System

Electrical Generation Output:	N/A (kW)	Number of Power Units:	
System Type:	(kW)	Fuel Source:	

Emergency and Critical System Loads (in the event of a service interruption)

Electric:	N/A (kW)	Heating:	(MMbtu/hr)
		Cooling:	(Tons/hr)

B – Greenhouse Gas Reduction and Net Zero / Net Positive Carbon Building Performance

Reducing GHG emissions is critical to avoiding more extreme climate change conditions. To achieve the City’s goal of carbon neutrality by 2050 new buildings performance will need to progressively improve to net carbon zero and positive.

B.1 – GHG Emissions - Design Conditions

For this Filing - Annual Building GHG Emissions: (Tons)

For this filing - describe how building energy performance has been integrated into project planning, design, and engineering and any supporting analysis or modeling:

Describe building specific passive energy efficiency measures including orientation, massing, envelop, and systems:

Describe building specific active energy efficiency measures including equipment, controls, fixtures, and systems:

Describe building specific load reduction strategies including on-site renewable, clean, and energy storage systems:

Describe any area or district scale emission reduction strategies including renewable energy, central energy plants, distributed energy systems, and smart grid infrastructure:

Describe any energy efficiency assistance or support provided or to be provided to the project:

B.2 - GHG Reduction - Adaptation Strategies

Describe how the building and its systems will evolve to further reduce GHG emissions and achieve annual carbon net zero and net positive performance (e.g. added efficiency measures, renewable energy, energy storage, etc.) and the timeline for meeting that goal (by 2050):

C - Extreme Heat Events

Annual average temperature in Boston increased by about 2° F in the past hundred years and will continue to rise due to climate change. By the end of the century, the average annual temperature could be 56° (compared to 46° now) and the number of days above 90° (currently about 10 a year) could rise to 90.

C.1 – Extreme Heat - Design Conditions

Temperature Range - Low:	<input type="text" value=""/>	Deg.	Temperature Range - High:	<input type="text" value=""/>	Deg.
Annual Heating Degree Days:	<input type="text" value=""/>		Annual Cooling Degree Days	<input type="text" value=""/>	

What Extreme Heat Event characteristics will be / have been used for project planning

Days - Above 90°:	<input type="text" value=""/>	#	Days - Above 100°:	<input type="text" value=""/>	#
Number of Heatwaves / Year:	<input type="text" value=""/>	#	Average Duration of Heatwave (Days):	<input type="text" value=""/>	#

Describe all building and site measures to reduce heat-island effect at the site and in the surrounding area:

C.2 - Extreme Heat – Adaptation Strategies

Describe how the building and its systems will be adapted to efficiently manage future higher average temperatures, higher extreme temperatures, additional annual heatwaves, and longer heatwaves:

Describe all mechanical and non-mechanical strategies that will support building functionality and use during extended interruptions of utility services and infrastructure including proposed and future adaptations:

D - Extreme Precipitation Events

From 1958 to 2010, there was a 70 percent increase in the amount of precipitation that fell on the days with the heaviest precipitation. Currently, the 10-Year, 24-Hour Design Storm precipitation level is 5.25". There is a significant probability that this will increase to at least 6" by the end of the century. Additionally, fewer, larger storms are likely to be accompanied by more frequent droughts.

D.1 – Extreme Precipitation - Design Conditions

10 Year, 24 Hour Design Storm: In.

Describe all building and site measures for reducing storm water run-off:

Currently, there is no formal drainage system located on the Site. The project includes the installation of a deep sump catch basin and subsurface drywell which will infiltrate at least 1" of rainfall falling on the entire property.

D.2 - Extreme Precipitation - Adaptation Strategies

Describe how site and building systems will be adapted to efficiently accommodate future more significant rain events (e.g. rainwater harvesting, on-site storm water retention, bio swales, green roofs):

All runoff from the redeveloped site will be collected and directed into a subsurface infiltration system. The mechanical room is located at the high point of the site and will be at an elevation approximately 1-ft higher than the climate resiliency anticipated flood plain elevation of 19.5.

E – Sea Level Rise and Storms

Under any plausible greenhouse gas emissions scenario, sea levels in Boston will continue to rise throughout the century. This will increase the number of buildings in Boston susceptible to coastal flooding and the likely frequency of flooding for those already in the floodplain.

Is any portion of the site in a FEMA SFHA?

YES

What Zone:

AE

Current FEMA SFHA Zone Base Flood Elevation:

16.46 Ft BCB

Is any portion of the site in a BPDA Sea Level Rise - Flood Hazard Area? Use the online [BPDA SLR-FHA Mapping Tool](#) to assess the susceptibility of the project site.

YES

If you answered YES to either of the above questions, please complete the following questions. Otherwise you have completed the questionnaire; thank you!

E.1 – Sea Level Rise and Storms – Design Conditions

Proposed projects should identify immediate and future adaptation strategies for managing the flooding scenario represented on the BPDA Sea Level Rise - Flood Hazard Area (SLR-FHA) map, which depicts a modeled 1% annual chance coastal flood event with 40 inches of sea level rise (SLR). Use the online [BPDA SLR-FHA Mapping Tool](#) to identify the highest Sea Level Rise - Base Flood Elevation for the site. The Sea Level Rise - Design Flood Elevation is determined by adding either 24” of freeboard for critical facilities and infrastructure and any ground floor residential units OR 12” of freeboard for other buildings and uses.

Sea Level Rise - Base Flood Elevation:	19.5	Ft BCB		
Sea Level Rise - Design Flood Elevation:	21.5	Ft BCB	First Floor Elevation:	21.6 Ft BCB
Site Elevations at Building:	15.4-21.6	Ft BCB	Accessible Route Elevation:	21.6 Ft BCB

Describe site design strategies for adapting to sea level rise including building access during flood events, elevated site areas, hard and soft barriers, wave / velocity breaks, storm water systems, utility services, etc.:

The buildings main entrance along Saratoga Street is located above the anticiapted flood plain elevation. All living space within the building will be located above the anticipated flood plain elevation. Equipment within the mechanical room will be installed above the flood plain elevation.

Describe how the proposed Building Design Flood Elevation will be achieved including dry / wet flood proofing, critical systems protection, utility service protection, temporary flood barriers, waste and drain water back flow prevention, etc.:

The buildings main entrance along Saratoga Street is located above the anticiapted flood plain elevation. All living space within the building will be located above the anticipated flood plain elevation. Equipment within the mechanical room will be installed above the flood plain elevation.

Describe how occupants might shelter in place during a flooding event including any emergency power, water, and waste water provisions and the expected availability of any such measures:

The living space and mechanical room associated with the new building will be located at least 1-foot above the anticipated future flood plain elevation. In addition, all utility infrastructure (including water/gas/electric meters, backflow preventer valves, and electrical switchgears will be located several feet above the anticipated future flood plain elevation. The building will be a well insulated structure having a tight thermal envelope. Also, several of the utility structures (including Condensers) will be installed on the roof of the new structure.

Describe any strategies that would support rapid recovery after a weather event:

No utility services are reliant on electricity or pumped systems. The water and sewer services function via pressure and gravity. The utility mains are located within Saratoga Street which is above the anticipated future flood plain elevation.

E.2 – Sea Level Rise and Storms – Adaptation Strategies

Describe future site design and or infrastructure adaptation strategies for responding to sea level rise including future elevating of site areas and access routes, barriers, wave / velocity breaks, storm water systems, utility services, etc.:

The first floor of the new building as well as all utility structures and piping is located above the anticipated future flood plain elevation.

Describe future building adaptation strategies for raising the Sea Level Rise Design Flood Elevation and further protecting critical systems, including permanent and temporary measures:

Utility systems are located above the anticipated future flood plain elevation.

A pdf and word version of the Climate Resiliency Checklist is provided for informational use and off-line preparation of a project submission. **NOTE: Project filings should be prepared and submitted using the online [Climate Resiliency Checklist](#).**

For questions or comments about this checklist or Climate Change best practices, please contact: John.Dalzell@boston.gov

2.0 Project Narrative

Project Narrative

2.1 Executive Summary

On behalf of 839 Saratoga St, LLC. (Applicant) and Mark W. Saviano (Owner), RJ O’Connell and Associates, Inc. (RJOC) is submitting this Application for a Notice of Intent (NOI) for a project proposed at 839 Saratoga Street in East Boston, Massachusetts (the Site). The Site is a 5,000 square foot lot currently comprised of a multi-story residential building ($\approx 1,190$ sf footprint), accompanying driveway, and parking area. The project consists of the demolition of the building and parking areas and the construction of a four (4) story multi-family building ($\approx 3,310$ sf footprint – second floor and above), driveway, and parking area.

A portion of this work will occur within the 100-year flood zone as defined by the Federal Emergency Management Agency (FEMA). Therefore, the Applicant is submitting this Notice of Intent (NOI) Application to the Boston Conservation Commission requesting the issuance of an Order of Conditions under the Massachusetts Wetlands Protection Act (M.G.L. c. 131 s. 40), its implementing Regulations (310 CMR 10.00), and the City of Boston Wetlands Ordinance.

As this Application and supporting documents will demonstrate, the proposed project has been designed to mitigate any adverse impacts the proposed project may have on the Protectable Wetland Resource Area. More specifically, this project has been designed to:

- provide compensatory flood storage onsite to offset any filling of existing flood storage located on the Site,
- mitigate any increase in overland stormwater runoff generated by the proposed development via the installation of an onsite stormwater management system, and
- installation of erosion and sedimentation control measures to reduce impacts offsite during construction activities.

As described within this Application, the proposed construction activities and sedimentation control measures for the project will meet the performance standards for the development. The proposed compensatory flood storage proposed will mitigate the flood storage lost and no adverse impacts are proposed to the resource area or wildlife habitat.

2.2 Existing Site Conditions & Environmental Characteristics

a. Existing Site Description

The Site is a 5,000 square-foot lot located at 839 Saratoga Street in East Boston, Massachusetts (*see “Figure 1 - USGS Map” in Section 3 of this Report*). The Site is bounded by Saratoga Street to the north, and residential lots to the south, east and west. The Site is entirely developed containing a multistory, multi-family residential building, bituminous concrete driveway and parking area, and minimal landscaped areas around the Site’s perimeter. The existing driveway is located along the western side of the building extending from Saratoga Street to a parking area located in the rear of the Site. The topography of the Site slopes from a high point along the frontage of Saratoga Street to the low point in the rear of the property. The rear portion of the Site is located within the 100-Year Floodplain as depicted by FEMA FIRM. Characteristics of the portion of the Site located below the 100-Year Floodplain elevation are included further in this Report.

b. FEMA Flood Zone

The southern portion of the Site is located within the 100-Year Floodplain Elevation as defined by the Federal Emergency Management Agency's (FEMA) Flood Insurance Rate Map (FIRM), Community Panel Number 25025C0019J, last revised March 16, 2016. More specifically, the FEMA FIRM depicts that the southern portion of the Site lies within a Zone AE having an assigned Base Flood Elevation of 10' (*North American Vertical Datum of 1988 (NAVD88)*). This elevation is equivalent to elevation 16.46' when converted to the Boston City Base Datum (*see "Figure 2 – Flood Insurance Rate Map" in Section 3 of this Report*).

Approximately 2,141 square-feet of the existing site is located below the Floodplain Zone AE elevation of 16.46' (BCB). The Site currently contains approximately 2,882 cubic feet of available flood storage on the site.

c. Habitat of Rare Species and Vernal Pools

The current Massachusetts Natural Heritage Atlas depicting the Site (last revised August 1, 2017) indicates that the project does not fall within an area of Estimated Habitat of Rare Wildlife and/or Priority Habitat of Rare Species as designated by the Massachusetts Natural Heritage and Endangered Species Program (NHESP) (*see "Figure 4 – ACEC Natural Heritage Map" in Section 3 of this Report*). In addition, no certified or potential vernal pools have been identified on the Site to date.

d. Area of Critical Environmental Concern (ACEC)

The project site is not located within or adjacent to an Area of Critical Environmental Concern.

2.3 Proposed Project

The proposed project consists of the demolition of the existing residential building on site and construction of a new multi-family residential building. In addition to the new building, a new driveway and parking area will be constructed as part of the project. Existing site utilities will be abandoned/cut and capped and new utilities (gas, water, fire suppression line, sewer, and electric/communication) will be installed to service the new building. Finally, an onsite stormwater management system consisting of a deep-sump catch basin with an oil trap, roof drain collection/piping network, and a subsurface infiltration system will be installed to collect, treat, infiltrate, and mitigate stormwater runoff generated by the proposed development. This stormwater management system has been designed to comply fully with the requirements set forth by the Boston Water and Sewer Commission and with the Massachusetts Stormwater Management Standards to the maximum extent practicable for a redevelopment project.

The finished grade of the redeveloped Site will essentially mimic that of the existing Site. As depicted on the attached design plans, the redeveloped Site will slope from a high point along the frontage of the Site to a low point in the new parking area located at the rear of the property.

To minimize impact to the 100-year floodplain located on the southern portion of the Site, (a) the new building has been sited on the northern portion of the lot, (b) has been designed to reduce the footprint of the first floor (*i.e., the southern portion of floors 2, 3, and 4 cantilevers over the rear parking area*), and (c) the proposed grading of the new driveway and parking area essentially mimic the topography of the existing site. The proposed finished floor has been designed at 21.50, or 2 feet above the climate resiliency anticipated floodplain elevation of 19.50.

2.4 Protectable Wetland Resource Areas & Associated Impacts

The proposed work will occur within the following resource areas which are subject to protection and regulation under the Massachusetts Wetlands Protection Act Regulations (310 CMR 10.00) and the Boston Wetlands Regulations:

- Land Subject to Coastal Storm Flowage (MA Protection Act Regulations)

Approximately 2,141 square-feet of the existing Site lies within the area defined as Land Subject to Coastal Storm Flowage. Within this area, approximately 2,882 cubic feet of flood storage is currently available. This entire area will be impacted during this project. Therefore, to mitigate this impact, the project has been designed to (a) increase the area of the Site located below the floodplain and (b) increase the volume of flood storage available on the Site. Table 1 provides a summary of these quantities before and after redevelopment of the Site.

Table 1: On-site Flood Storage Comparison

	<u>Existing</u>	<u>Proposed</u>	<u>Increase</u>
Area of Site Below 100-Year Floodplain (square feet)	2,141 ±	2,212 ±	71 ±
Volume on Site within 100-Year Floodplain (cubic feet)	2,882 ±	3,213 ±	331 ±

(a) Land Subject to Coastal Storm Flowage

Description & Extent of Resource Area

Per 310 CMR 10.04, Land Subject to Coastal Storm Flowage (LSCSF) is defined as: *Land subject to any inundation caused by coastal storms up to and including by the 100-year storm, surge of record or storm of record, whichever is greater.*

Per 310 CMR 10.04, the limit of a LSCSF is defined as the Special Flood Hazard Area, or *the area of land in the flood plain that is subject to a 1% chance of flooding in any given year as determined by the best available information, including, but not limited to, the currently effective or preliminary Federal Emergency Management Agency (FEMA) Flood Insurance Study or Rate Map (except for any portion of a preliminary map that is the subject of an appeal to FEMA) for Land Subject to Coastal Storm Flowage, the Velocity Zone, as defined in 301 CMR 10.04, and the Flood Insurance Study for Bordering Land Subject to Flooding as defined in 310 CMR 10.57.*

Impact of Proposed Project on Resource Area

As mentioned previously in this Report, the proposed project involves the demolition of the existing residential building on site and the construction of a new multi-family residential building and associated parking and appurtenances. This work will occur partially within the 100-year Floodplain as depicted on the FEMA FIRM. A summary of impacts is presented below.

- The Base Flood Elevation of the Chelsea Creek associated with the proposed work area is elevation 10' (NAVD88) or 16.46' (BCB).

- Existing Onsite Flood Storage Affected = 2,882 cubic feet ±
- Onsite Flood Storage Provided after Construction = 3,213 cubic feet ±
- Additional Flood Storage Provided = 331 cubic feet ±

Land Subject to Coastal Storm Flowage is present on site. Since the Massachusetts Wetland Protection Act does not provide Performance Standards for this Resource Area, we have referenced the Performance Standards (or guidelines) outlined for Land Subject to Coastal Storm Flowage as published withing Chapter 2 of the document entitled “*Applying the Massachusetts Coastal Wetland Regulations: A practical Manual for Conservation Commissions to Protect the Storm Damage Prevention and Flood Control Functions of Coastal Resource Areas.*” The Performance Standards we have addressed are as follows:

Conformance with Specific Performance Standards (Guidelines) for Land Subject to Coastal Storm Flowage

- *Projects that reduce vegetation and pervious areas in the coastal floodplain may reduce the surfaces that can detain, absorb, slow, or evaporate flood waters, thereby changing the drainage characteristics in a manner that could cause increased flood damage on adjacent properties.*

Under existing conditions, the area of the site within the flood plain that is proposed to be altered has limited vegetation and is surrounded by existing impervious surfaces. The installation of a deep sump catch basin and infiltration system on the site will assist in the detainment and infiltration of stormwater on site. These site improvements will result in a reduction of flood water flowing off the site, and thereby will reduce flood damage on abutting properties

- *Buildings on solid foundations, slabs, and curbs and landscaping walls, fill, and other hard and impervious surfaces may have the effect of channeling flood waters, which increases the velocity of flow to adjacent areas. These obstructions to water flow may also deflect, reflect, or redirect wave energy, overwash, and flood waters onto adjacent resource areas, properties, and private and public roads.*

The grading on site has been proposed in such a manner, that any areas where channeling may occur are directed to the proposed deep sump catch basin, rather than to any adjacent roadways or properties.

- *Filling hydraulically restricted areas with sediments or other materials could displace the area where flood waters would otherwise be confined or detained and increase flood levels on the subject and adjacent properties. Hydraulically restricted areas include areas where ponding occurs from overwash or where pipes, culverts, dikes, or other physical restrictions limit water flow.*

The proposed grading on site has been designed in such a way as to provide more flood storage on the site than that which is currently provided on the site. The total volume of existing and proposed flood storage available on the Site is summarized in Table 2:

Table 2: Interval Flood Storage Comparison

<u>Elevation Interval</u>	<u>Existing Flood Storage Volume (cubic feet)</u>	<u>Proposed Flood Storage Volume (cubic feet)</u>	<u>Increase (cubic feet)</u>
16 – 16.46	1,029 ±	1,174 ±	145 ±
15 – 16	1,529 ±	1,605 ±	76 ±
14 – 15	324 ±	427 ±	103 ±
13 - 14	0	7 ±	7 ±
Total	2,882	3,213	331

- o *Coastal engineering structures in V Zones or Coastal A Zones may deflect, reflect, and redirect storm waves, affecting adjacent properties, landward areas, and the subject property with wave energy, overwash, and flood waters.*

The project is not located within a V or Coastal A Zone.

- o *Dredging or the removal of materials within the coastal floodplain allows storm waves to break farther inland and to impact upland and wetland resource areas.*

No dredging is proposed as a part of this project, and any removal of onsite material shall not adversely affect any of the project’s abutters or resource areas. In addition, based upon the maps available from FEMA and CZM, this site is not anticipated to experience action from storm waves.

2.5 Proposed Sedimentation & Erosion Control Mitigation Impacts

Several measures will be undertaken during construction to protect the floodplain resource area during the construction of this project. Silt fencing will be installed downgradient of all disturbance activities and silt sacks or an equivalent product will be installed into active catch basins prior to construction or disturbance on Site. Storage of construction materials and vehicles will be kept onsite to the maximum extent feasible. Routine site inspections and cleanup will be implemented throughout construction.

The following mitigation measures will be put into effect in order to protect the resource areas mentioned above throughout construction of the proposed project.

a. Sedimentation and Debris Control

Prior to commencement of construction activities, the contractor shall silt fencing on the downgradient edge of all disturbance activities. The contractor shall inspect the silt fencing on a daily basis to confirm that (a) no tears or rips are present in the silt fencing and that the fencing is properly implemented, (b) are securely in place, and (c) that sediment and debris has not exceeded 3-6 inches in depth upgradient of the silt fence.

All active catch basins on site shall have silt sacks or equivalent installed to prevent sedimentation and clogging. The silt sacks shall be inspected weekly to ensure they are still in good working order. Any tears in the fabric or liner shall be removed and replaced immediately. Any sediment or debris that has entered the catch basin shall be promptly removed prior to re-installation of the silt sack.

2.6 Stormwater Management

Overview

The existing site is sloped from Saratoga Street south towards the rear of the Site. Stormwater runoff that lands on the existing roof is collected and discharged from roof leaders to the existing driveway or landscaped areas in the back yard. Runoff that lands on the driveway is conveyed via overland flow to the rear of the lot along the southern property line where an existing low point is located.

Under proposed redeveloped conditions, stormwater runoff landing on the roof of the new building will be collected and discharged directly into a subsurface infiltration system. Runoff that is collected over the uncovered portion of the proposed parking area will be collected by a deep sump catch basin (with an oil trap) and conveyed to the subsurface infiltration system. The subsurface infiltration system has been sized to retain and infiltrate the first inch of runoff generated by the entire redeveloped Site (i.e., the Water Quality Volume).

Stormwater Management Standards

1. *No new stormwater conveyances (e.g. outfalls) may discharge untreated stormwater directly to or cause erosion in wetlands or waters of the Commonwealth.*

The proposed project does not propose to install any new methods of stormwater conveyances or outfalls. Any stormwater runoff flowing off the redeveloped Site will do so as it does under the current existing conditions.

2. *Stormwater management systems shall be designed so that post-development peak discharge rates do not exceed pre-development peak discharge rates. This Standard may be waived for discharges to land subject to coastal storm flowage as defined in 310 CMR 10.04.*

The stormwater management system has been designed to collect, retain and infiltrate the first inch of runoff to the maximum extent practical. This standard is waived as the site discharges to Land Subject to Coastal Storm Flowage.

3. *Loss of annual recharge to groundwater shall be eliminated or minimized through the use of infiltration measures including environmentally sensitive site design, low impact development techniques, stormwater best management practices, and good operation and maintenance. At a minimum, the annual recharge from the post-development site shall approximate the annual recharge from pre-development conditions based on soil type. This Standard is met when the stormwater management system is designed to infiltrate the required recharge volume as determined in accordance with the Massachusetts Stormwater Handbook.*

The existing Site does not have any formal drainage system. However, the redeveloped Site has been designed with a formal onsite stormwater management system. The proposed stormwater

management system is comprised of a deep sump catch basin (with an oil trap) and a subsurface infiltration system that has been designed to collect, retain and infiltrate the first inch of runoff.

4. *Stormwater management systems shall be designed to remove 80% of the average annual post-construction load of Total Suspended Solids (TSS). This Standard is met when:*
 - a. *Suitable practices for source control and pollution prevention are identified in a long-term pollution prevention plan, and thereafter are implemented and maintained;*
 - b. *Structural stormwater best management practices are sized to capture the required water quality volume determined in accordance with the Massachusetts Stormwater Handbook; and*
 - c. *Pretreatment is provided in accordance with the Massachusetts Stormwater Handbook.*

The proposed project is a redevelopment project consisting of the removal of an existing building and construction of a new multi-family building. The proposed stormwater management system is designed to remove Total Suspended Solids prior to entering the subsurface stormwater management system to the maximum amount practicable via a deep-sump catch basin. The majority of the parking area is located beneath the cantilevered building above. The majority of the runoff generated by the redeveloped Site will be created by the roof of the new building. Runoff from the roof is considered clean.

5. *For land uses with higher potential pollutant loads, source control and pollution prevention shall be implemented in accordance with the Massachusetts Stormwater Handbook to eliminate or reduce the discharge of stormwater runoff from such land uses to the maximum extent practicable. If through source control and/or pollution prevention all land uses with higher potential pollutant loads cannot be completely protected from exposure to rain, snow, snow melt, and stormwater runoff, the proponent shall use the specific structural stormwater BMPs determined by the Department to be suitable for such uses as provided in the Massachusetts Stormwater Handbook. Stormwater discharges from land uses with higher potential pollutant loads shall also comply with the requirements of the Massachusetts Clean Waters Act, M.G.L. c. 21, §§ 26-53 and the regulations promulgated thereunder at 314 CMR 3.00, 314 CMR 4.00 and 314 CMR 5.00.*

The project is not associated with any Land Uses with Higher Potential Pollutant Loads.

6. *Stormwater discharges within the Zone II or Interim Wellhead Protection Area of a public water supply, and stormwater discharges near or to any other critical area, require the use of the specific source control and pollution prevention measures and the specific structural stormwater best management practices determined by the Department to be suitable for managing discharges to such areas, as provided in the Massachusetts Stormwater Handbook. A discharge is near a critical area if there is a strong likelihood of a significant impact occurring to said area, taking into account site-specific factors. Stormwater discharges to Outstanding Resource Waters and Special Resource Waters shall be removed and set back from the receiving water or wetland and receive the highest and best practical method of treatment. A “storm water discharge” as defined in 314 CMR 3.04(2)(a)1 or (b) to an Outstanding Resource Water or Special Resource Water shall comply with 314 CMR 3.00 and 314 CMR 4.00. Stormwater discharges to a Zone I or Zone A are prohibited unless essential to the operation of a public water supply.*

The project area is not located within a Zone II, an Interim Wellhead Protection Area, or a critical area as defined above.

7. *A redevelopment project is required to meet the following Stormwater Management Standards only to the maximum extent practicable: Standard 2, Standard 3, and the pretreatment and structural best management practice requirements of Standards 4, 5, and 6. Existing stormwater discharges shall comply with Standard 1 only to the maximum extent practicable. A redevelopment project shall also comply with all other requirements of the Stormwater Management Standards and improve existing conditions.*

The proposed project is a redevelopment project consisting of the removal of an existing building and construction of a new building and meets all applicable stormwater management standards.

8. *A plan to control construction-related impacts including erosion, sedimentation and other pollutant sources during construction and land disturbance activities (construction period erosion, sedimentation, and pollution prevention plan) shall be developed and implemented.*

The proposed project will disturb approximately 5,000 SF (significantly less than 1.0 acres) and therefore coverage under the CGP is not required.

Erosion and sedimentation control measures have been proposed as part of this project to control construction-related impacts that could occur during construction. Some examples of these control measures include, but are not limited to, the installation of silt fence downgradient from disturbance activities, site cleanup requirements, and identification/requirement of areas for storage of construction equipment, materials, and debris. These measures are depicted on the plans and details contained within the Notice of Intent Application.

9. *A long-term operation and maintenance plan shall be developed and implemented to ensure that stormwater management systems function as designed.*

A long-term operation and maintenance plan has been developed and will be implemented upon completion of construction.

10. *All illicit discharges to the stormwater management system are prohibited.*

A signed illicit discharge statement has been included with this Notice of Intent.

2.7 Resiliency

The new building has been designed such that the lowest floor elevation is above the existing 100-year floodplain elevation by approximately five (5') feet. The proposed first floor has been raised as high as possible due to the elevation of the abutting Saratoga Street and providing ADA accessibility. The three floors above the first floor have been designed to be cantilevered over the rear of the yard. All new utility connections are proposed to connect to the building as close to the Street as possible.

The project also proposes to implement a number of strategies to reduce the impacts of increased heat, or Heat Island effect on the project site. These strategies include the use of a white EPDM roof and the use of light-colored paint on the majority of the building to reduce Urban Heat Island effects. Additionally, the project proposes limiting the amount of paved area on site as much as possible and including multiple tree plantings and maximizing vegetated areas to provide shade and cooler surface temperatures.

NOTICE OF INTENT APPLICATION
March 2021 –839 Saratoga Street, East Boston

This project has also been designed to minimize and/or have no adverse effect upon the nearby resource areas. More specifically, it is our belief that the project will protect the Resource Area Values outlined in the City of Boston's updated Ordinance.

More specifically, the proposed project will not change the existing drainage characteristics of the area proposed to be redeveloped. The flow patterns of runoff will remain unchanged from the patterns currently in existence. The stormwater management system has been designed to collect runoff from impervious areas and provide additional treatment from existing conditions and meet the Stormwater Management Standards as required by MassDEP.

2.8 Summary

The Applicant is seeking to obtain an Order of Conditions from the Boston Conservation Commission to permit the demolition of an existing residential building and construction of a new multi-family residential building located on this property of which portions lie within the 100-year floodplain (Land Subject to Coastal Storm Flowage). The proposed compensatory flood storage meets or exceeds the flood storage loss associated with this project. Additionally, the proposed stormwater management system has been designed to mitigate stormwater runoff and provide additional treatment prior to discharge. As such, the proposed development will have no negative impacts to resource areas.

3.0 Figures

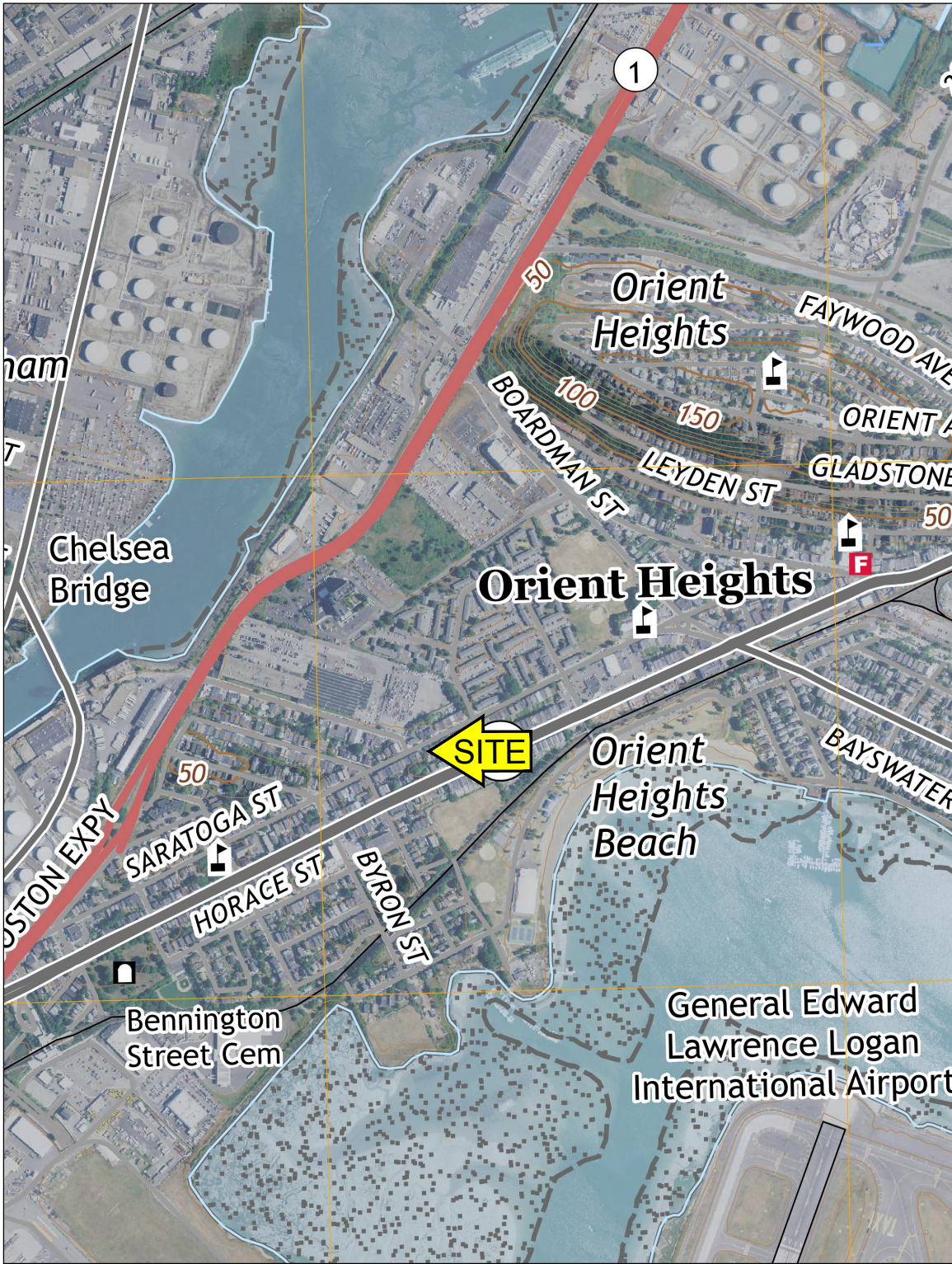
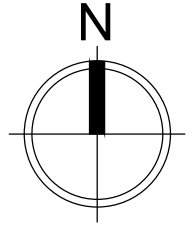

1,000 0 500 1,000 2,000



GRAPHIC SCALE IN FEET

RJO'CONNELL & ASSOCIATES, INC.
 CIVIL ENGINEERS, SURVEYORS & LAND PLANNERS

DATE: 02/16/2021 SCALE: 1"=1000'

FIGURE 1
USGS MAP

PARCEL ID: 0101025000
 BOSTON, MA

Drawing name: G:\MA\Boston\Volnay Capital\839 Saratoga Street\Reports\N01\Figures\20155_FIG-1 USGS.dwg
Feb 16, 2021 16:40pm

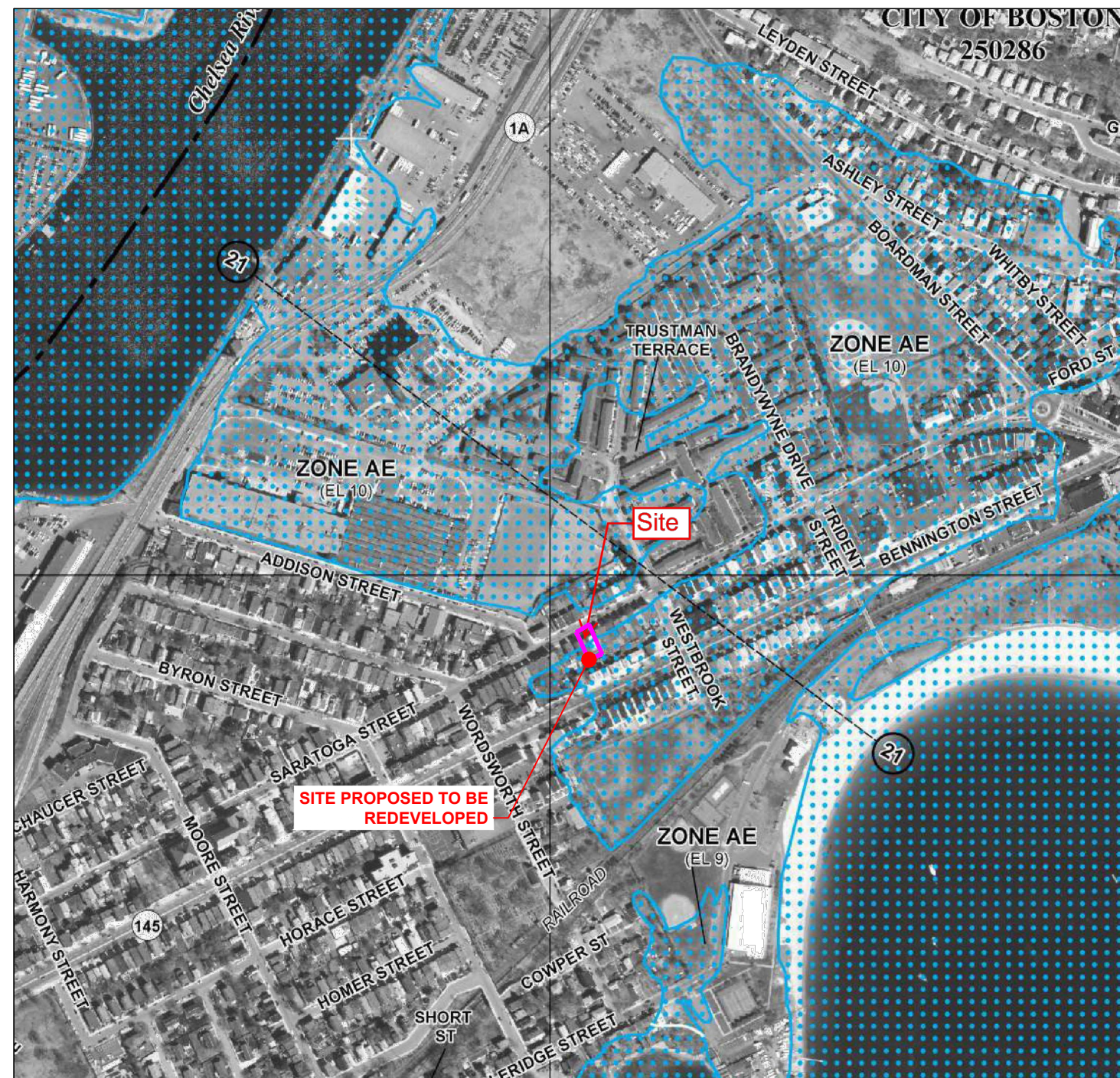
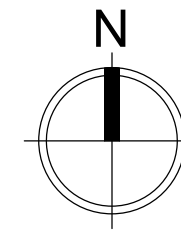



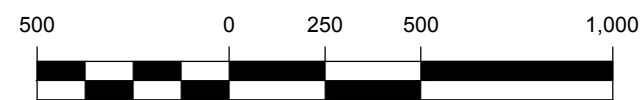



SITE PROPOSED TO BE REDEVELOPED

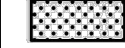

GRAPHIC SCALE IN FEET

LEGEND

-  **SPECIAL FLOOD HAZARD AREAS (SFHAS) SUBJECT TO INUNDATION BY THE 1% ANNUAL CHANCE FLOOD**
The 1% annual chance flood (100-year flood), also known as the base flood, is the flood that has a 1% chance of being equaled or exceeded in any given year. The Special Flood Hazard Area is the area subject to flooding by the 1% annual chance flood. Areas of Special Flood Hazard include Zones A, AE, AH, AO, AR, A99, V, and VE. The Base Flood Elevation is the water-surface elevation of the 1% annual chance flood.
- ZONE A** No Base Flood Elevations determined.
- ZONE AE** Base Flood Elevations determined.
- ZONE AH** Flood depths of 1 to 3 feet (usually areas of ponding); Base Flood Elevations determined.
- ZONE AO** Flood depths of 1 to 3 feet (usually sheet flow on sloping terrain); average depths determined. For areas of alluvial fan flooding, velocities also determined.
- ZONE AR** Special Flood Hazard Areas formerly protected from the 1% annual chance flood by a flood control system that was subsequently decertified. Zone AR indicates that the former flood control system is being restored to provide protection from the 1% annual chance or greater flood.
- ZONE A99** Area to be protected from 1% annual chance flood by a Federal flood protection system under construction; no Base Flood Elevations determined.
- ZONE V** Coastal flood zone with velocity hazard (wave action); no Base Flood Elevations determined.
- ZONE VE** Coastal flood zone with velocity hazard (wave action); Base Flood Elevations determined.
-  **FLOODWAY AREAS IN ZONE AE**
The floodway is the channel of a stream plus any adjacent floodplain areas that must be kept free of encroachment so that the 1% annual chance flood can be carried without substantial increases in flood heights.
-  **OTHER FLOOD AREAS**
- ZONE X** Areas of 0.2% annual chance flood; areas of 1% annual chance flood with average depths of less than 1 foot or with drainage areas less than 1 square mile; and areas protected by levees from 1% annual chance flood.
-  **OTHER AREAS**
- ZONE X** Areas determined to be outside the 0.2% annual chance floodplain.
- ZONE D** Areas in which flood hazards are undetermined, but possible.
-  **COASTAL BARRIER RESOURCES SYSTEM (CBRS) AREAS**
-  **OTHERWISE PROTECTED AREAS (OPAs)**

RJO'CONNELL & ASSOCIATES, INC.

CIVIL ENGINEERS, SURVEYORS & LAND PLANNERS

DATE: 02/16/2021

SCALE: 1"=500'

FIGURE 2 FLOOD INSURANCE RATE MAP

PARCEL ID: 0101025000
BOSTON, MA

Copyright © 2021 by R.J. O'Connell & Associates, Inc.

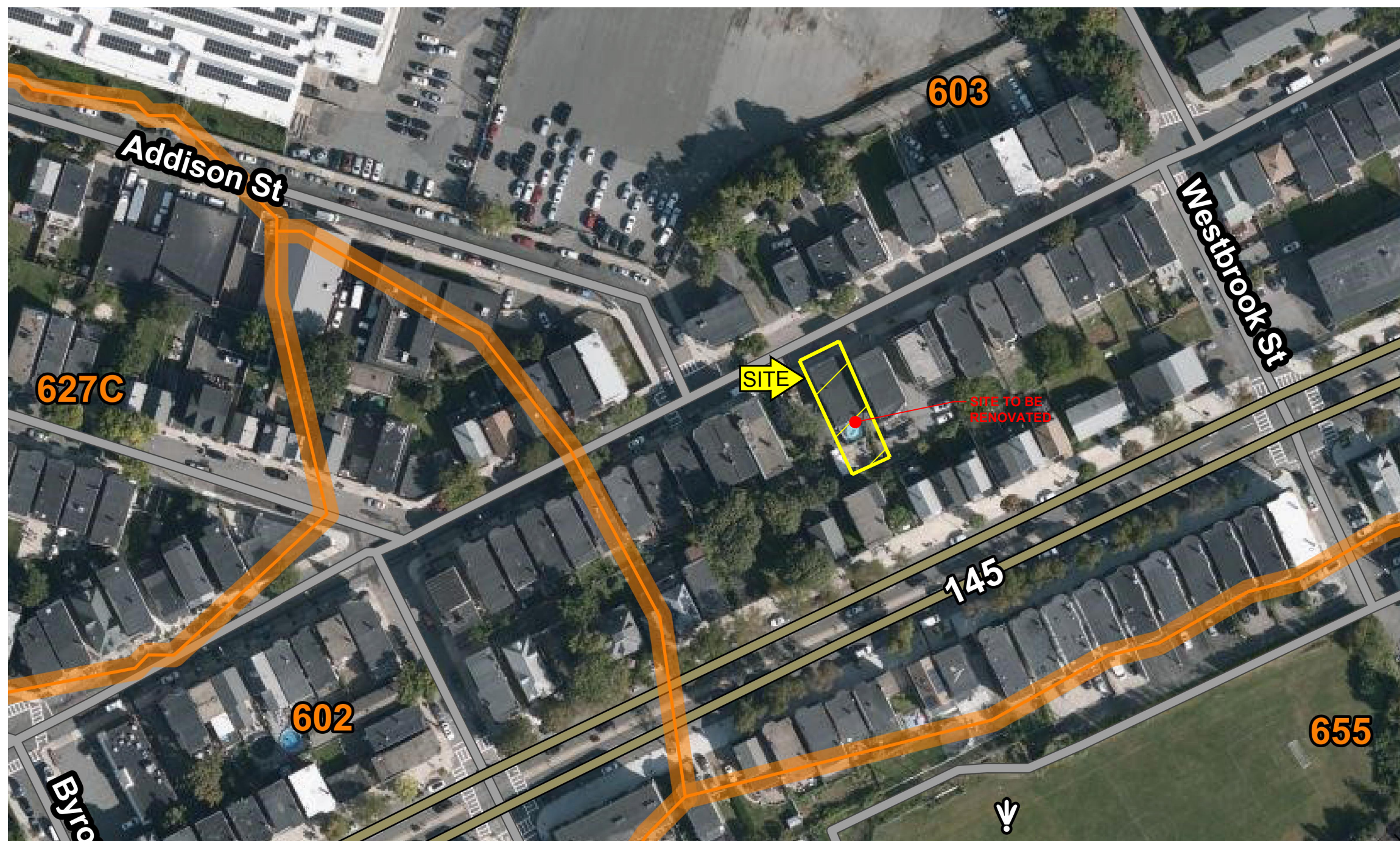
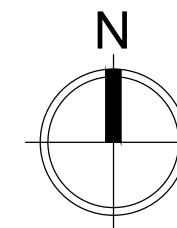

NRCS SOIL MAP LEGEND		
MAP UNIT SYMBOL	MAP UNIT NAME	HSG
602	URBAN LAND 0-15% SLOPES	
603	URBAN LAND, WET SUBSTRATUM, 0-3% SLOPES	
610	BEACHES, SAND	
627C	NEWPORT-URBAN LAND COMPLEX, 3-15% SLOPES	B
655	UDORTHENTS, WET SUBSTRATUM	

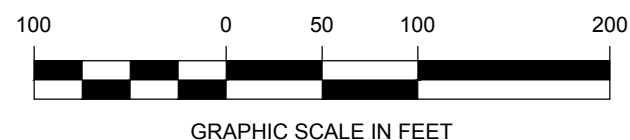

RJO'CONNELL & ASSOCIATES, INC.
 CIVIL ENGINEERS, SURVEYORS & LAND PLANNERS
 DATE: 02/16/2021 SCALE: 1"=100'
FIGURE 3
NRCS WEB SOIL SURVEY MAP
 PARCEL ID: 0101025000
 BOSTON, MA

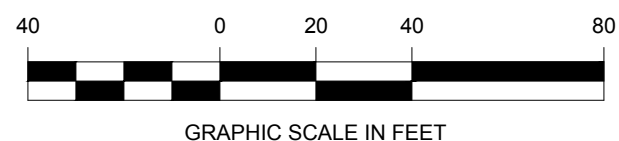
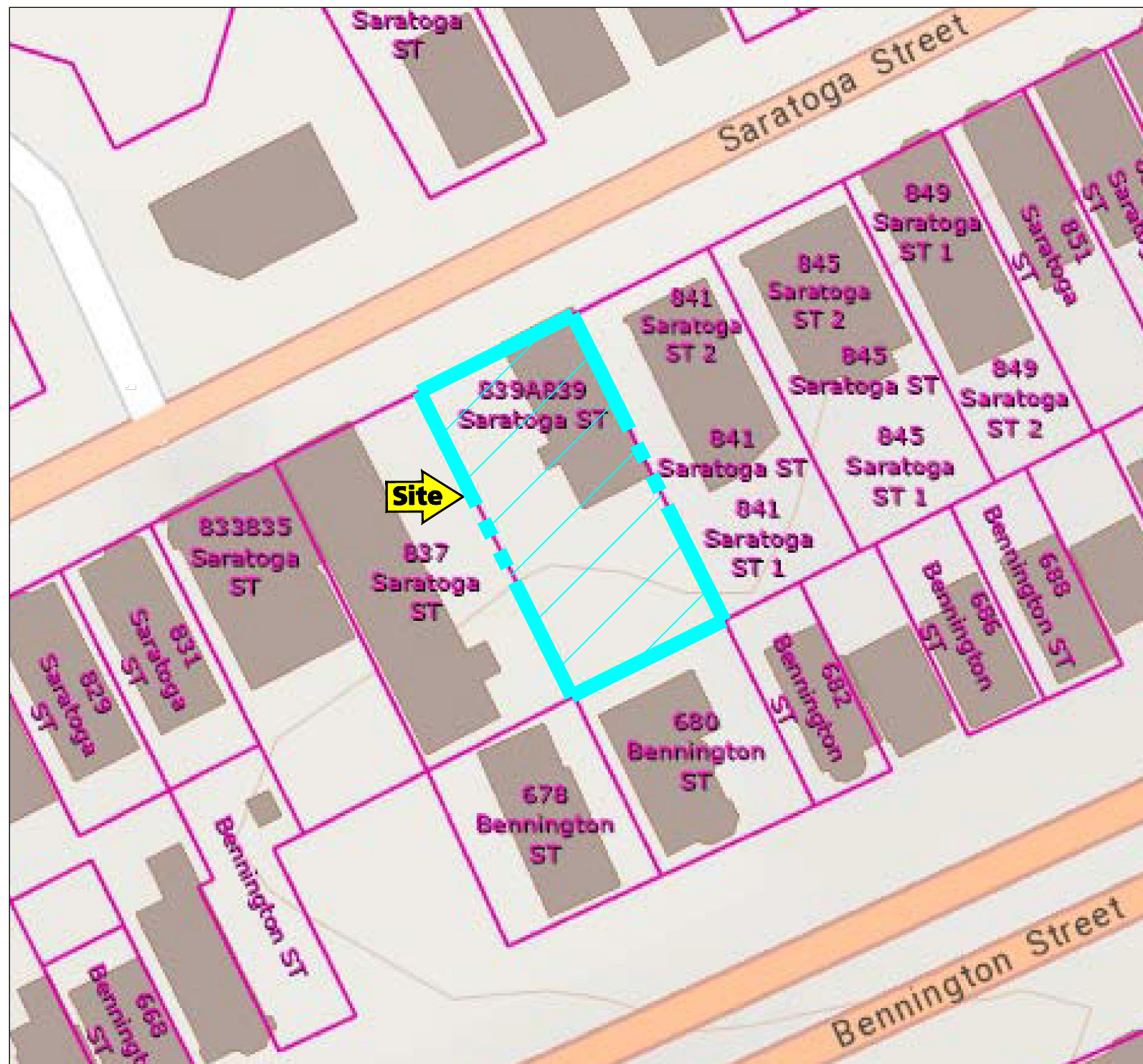
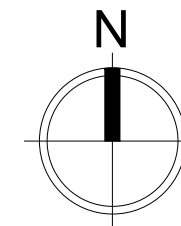

GRAPHIC SCALE IN FEET

- NHESP Priority Habitats of Rare Species
 -
- Potential Vernal Pools
 -
- NHESP Estimated Habitats of Rare Wildlife
 -
- NHESP Certified Vernal Pools
 -
- Zone Is
 -
- Zone IIs
 -
- IWPAs
 -
- DEP Wetlands Detailed With Outlines
 - Barrier Beach System
 - Barrier Beach-Deep Marsh
 - Barrier Beach-Wooded Swamp Mixed Trees
 - Barrier Beach-Coastal Beach
 - Barrier Beach-Coastal Dune
 - Barrier Beach-Marsh
 - Barrier Beach-Salt Marsh
 - Barrier Beach-Shrub Swamp
 - Barrier Beach-Wooded Swamp Coniferous
 - Barrier Beach-Wooded Swamp Deciduous
 - Bog
 - Coastal Bank Bluff or Sea Cliff
 - Coastal Beach
 - Coastal Dune
 - Cranberry Bog
 - Deep Marsh
 - Barrier Beach-Open Water
 - Open Water
 - Rocky Intertidal Shore
 - Salt Marsh
 - Shallow Marsh Meadow or Fen
 - Shrub Swamp
 - Tidal Flat
 - Wooded Swamp Coniferous
 - Wooded Swamp Deciduous
 - Wooded Swamp Mixed Trees
- DEP Wetlands Arcs
 - SHORELINE
 - HYDROLOGIC CONNECTION
 - MEAN WATER LINE
 - APPARENT WETLAND LIMIT
 - CLOSURE LINE
 - EDGE OF INTERPRETED AREA
- Areas of Critical Environmental Concern ACECs
 -

RJO'CONNELL & ASSOCIATES, INC.
 CIVIL ENGINEERS, SURVEYORS & LAND PLANNERS
 DATE: 02/16/2021 SCALE: 1"=40'
FIGURE 4
ACEC NATURAL HERITAGE MAP
 839 SARATOGA STREET
 BOSTON, MA 02128

Drawing name: G:\MA\Boston\Volnay Capital\839 Saratoga Street\Reports\NOI\Figures\20155_FIG-4 Resource Map.dwg
 Feb 16, 2021 - 16:37pm

4.0 Existing Site Photographs



Existing Front Entrance from Saratoga Street



Existing Residential Building from Saratoga Street Facing East



Existing Back Yard and Residential Building Facing North



Existing Back Yard Facing East



Existing Driveway Facing South



Existing Back Yard and Planter Wall Facing Northwest



Existing Back Yard Facing West



Existing Eastern Side Yard Facing North



Existing Western Side Yard Facing North

5.0 Abutters Notification Information



NOTIFICATION TO ABUTTERS
BOSTON CONSERVATION COMMISSION

In accordance with the Massachusetts Wetlands Protection Act, Massachusetts General Laws Chapter 131, Section 40, and the Boston Wetlands Ordinance, you are hereby notified as an abutter to a project filed with the Boston Conservation Commission.

- A. **839 Saratoga St, LLC** has filed a Notice of Intent with the Boston Conservation Commission seeking permission to alter an Area Subject to Protection under the Wetlands Protection Act (General Laws Chapter 131, section 40) and Boston Wetlands Ordinance.
- B. The address of the lot where the activity is proposed is **839 Saratoga Street Boston, MA.**
- C. The project involves **demolition of an existing residential building and construction of a new multi-family residential building.**
- D. Copies of the Notice of Intent may be obtained by contacting the Boston Conservation Commission at CC@boston.gov.
- E. Copies of the Notice of Intent may be obtained from **Brian Timm, at RJ O'Connell & Associates, inc.** by calling **(781) 279-0180 x142** between the hours of **8:00 am and 5:00 pm, Monday-Friday.**
- F. In accordance with the Commonwealth of Massachusetts Executive Order Suspending Certain Provisions of the Open Meeting Law, the public hearing will take place **virtually** at <https://zoom.us/j/6864582044>. If you are unable to access the internet, you can call 1-929-205-6099, enter Meeting ID 686 458 2044 # and use # as your participant ID.
- G. Information regarding the date and time of the public hearing may be obtained from the **Boston Conservation Commission** by emailing CC@boston.gov or calling **(617) 635-3850** between the hours of **9 AM to 5 PM, Monday through Friday.**

NOTE: Notice of the public hearing, including its date, time, and place, will be published at least five (5) days in advance in the **Boston Herald.**

NOTE: Notice of the public hearing, including its date, time, and place, will be posted on www.boston.gov/public-notices and in Boston City Hall not less than forty-eight (48) hours in advance.

NOTE: If you would like to provide comments, you may attend the public hearing or send written comments to CC@boston.gov or Boston City Hall, Environment Department, Room 709, 1 City Hall Square, Boston, MA 02201

NOTE: You also may contact the Boston Conservation Commission or the Department of Environmental Protection Northeast Regional Office for more information about this application or the Wetlands Protection Act. To contact DEP, call: the Northeast Region: (978) 694-3200.



NOTIFICACIÓN PARA PROPIETARIOS Y/O VECINOS COLINDANTES
COMISIÓN DE CONSERVACIÓN DE BOSTON

De conformidad con la Ley de protección de los humedales de Massachusetts, el Capítulo 131, Sección 40 de las Leyes Generales de Massachusetts y la Ordenanza sobre los humedales de Boston, por la presente queda usted notificado como propietario o vecino colindante de un proyecto presentado ante la Comisión de Conservación de Boston.

A. **839 Saratoga St, LLC** ha presentado una solicitud a la Comisión de Conservación de Boston pidiendo permiso para modificar una zona sujeta a protección en virtud de la Ley de protección de los humedales (Leyes generales, capítulo 131, sección 40) y la Ordenanza sobre los humedales de Boston.

B. La dirección del lote donde se propone la actividad es **839 Saratoga Street Boston, MA**.

C. El proyecto implica la demolición de un área de estacionamiento y edificio residencial existente en el sitio, y la construcción de un nuevo edificio residencial multifamiliar con área de estacionamiento asociada.

D. Se pueden obtener copias del Aviso de Intención comunicándose con la Comisión de Conservación de Boston en CC@boston.gov.

E. Pueden solicitarse copias de la Notificación de Intención a Brian Timm, brian.timm@rjoconnell.com, de R J O'Connell & Associates, Inc., entre las 9 a. m. y las 5 p. m., de lunes a viernes.

F. De acuerdo con el Decreto Ejecutivo de la Mancomunidad de Massachusetts que suspende ciertas disposiciones de la Ley de reuniones abiertas, la audiencia pública se llevará a cabo virtualmente en <https://zoom.us/j/6864582044>. Si no puede acceder a Internet, puede llamar al 1-929-205- 6099, ingresar ID de reunión 686 458 2044 # y usar # como su ID de participante.

G. La información relativa a la fecha y hora de la audiencia pública puede solicitarse a la **Comisión de Conservación de Boston** por correo electrónico a CC@boston.gov o llamando al **(617) 635-4416** entre las **9 AM y las 5 PM, de lunes a viernes**.

NOTA: La notificación de la audiencia pública, incluida su fecha, hora y lugar, se publicará en el **Boston Herald** con al menos cinco (5) días de antelación.

NOTA: La notificación de la audiencia pública, incluida su fecha, hora y lugar, se publicará en www.boston.gov/public-notice y en el Ayuntamiento de Boston con no menos de cuarenta y ocho (48) horas de antelación. Si desea formular comentarios, puede asistir a la audiencia pública o enviarlos por escrito a CC@boston.gov o al Ayuntamiento de Boston, Departamento de Medio Ambiente, Sala 709, 1 City Hall Square, Boston, MA 02201.

NOTA: También puede comunicarse con la Comisión de Conservación de Boston o con la Oficina Regional del Noreste del Departamento de Protección Ambiental para obtener más información sobre esta solicitud o la Ley de Protección de Humedales. Para comunicarse con el DEP, llame a la Región Noreste: (978) 694-3200.

NOTA: si tiene previsto asistir a la audiencia pública y necesita servicios de interpretación, sírvase informar al personal en CC@boston.gov antes de las 12 PM del día anterior a la audiencia.

Date: February 16th, 2021

Certificate of Accurate Translation

Translated document: Technical / Engineering Expert Translation

Translation date: February 16th, 2021

Project #: 7997180

Source Language: English

Target Language: Spanish (Latin-America)

, the largest professional translation agency online, hereby certifies and states the following, that the above mentioned document has been translated by a certified professional translator who has the background and the experience needed to perform the translation. We further certify that, to the best of our knowledge, the translated document is accurate translation of the original document and that it reflects the content, style and meaning of the original document.

This certificate relates to the accuracy of the translation only and not to the original content of the document. In accordance with our general terms and conditions, is not liable and will not be held liable to any result of using the translation by the client or any other party.

Please find the translation attached.

Yours Sincerely,





BABEL NOTICE

English:

IMPORTANT! This document or application contains **important information** about your rights, responsibilities and/or benefits. It is crucial that you understand the information in this document and/or application, and we will provide the information in your preferred language at no cost to you. If you need them, please contact us at cc@boston.gov or 617-635-3850.

Spanish:

¡IMPORTANTE! Este documento o solicitud contiene **información importante** sobre sus derechos, responsabilidades y/o beneficios. Es fundamental que usted entienda la información contenida en este documento y/o solicitud, y le proporcionaremos la información en su idioma preferido sin costo alguno para usted. Si los necesita, póngase en contacto con nosotros en el correo electrónico cc@boston.gov o llamando al 617-635-3850.

Haitian Creole:

AVI ENPÒTAN! Dokiman oubyen aplikasyon sa genyen **enfòmasyon ki enpòtan** konsènan dwa, responsablite, ak/oswa benefis ou yo. Li enpòtan ke ou konprann enfòmasyon ki nan dokiman ak/oubyen aplikasyon sa, e n ap bay enfòmasyon an nan lang ou prefere a, san ou pa peye anyen. Si w bezwen yo, tanpri kontakte nou nan cc@boston.gov oswa 617-635-3850.

Traditional Chinese:

非常重要！這份文件或是申請表格包含關於您的權利，責任，和／或福利的重要信息。請您務必完全理解這份文件或申請表格的全部信息，這對我們來說十分重要。我們會免費給您提供翻譯服務。如果您有需要請聯系我們的郵箱 cc@boston.gov 電話# 617-635-3850..

Vietnamese:

QUAN TRỌNG! Tài liệu hoặc đơn yêu cầu này chứa **thông tin quan trọng** về các quyền, trách nhiệm và/hoặc lợi ích của bạn. Việc bạn hiểu rõ thông tin trong tài liệu và/hoặc đơn yêu cầu này rất quan trọng, và chúng tôi sẽ cung cấp thông tin bằng ngôn ngữ bạn muốn mà không tính phí. Nếu quý vị cần những dịch vụ này, vui lòng liên lạc với chúng tôi theo địa chỉ cc@boston.gov hoặc số điện thoại 617-635-3850.

Simplified Chinese:

非常重要！这份文件或是申请表格包含关于您的权利，责任，和／或福利的重要信息。请您务必完全理解这份文件或申请表格的全部信息，这对我们来说十分重要。我们会免费给您提供翻译服务。如果您有需要请联联系我们的邮箱 cc@boston.gov 电话# 617-635-3850.

Cape Verdean Creole:

INPURTANTI! Es dukumentu ó aplikason ten **informason inpur tanti** sobri bu direitus, rasponsabilidadi i/ó benefisius. Ê krusial ki bu intendi informason na es dukumentu i/ó aplikason ó nu ta da informason na língua di bu preferênsia sen ninhun kustu pa bó. Si bu prisiza del, kontata-nu na cc@boston.gov ó 617-635-3850.

Arabic:

مهم! يحتوي هذا المستند أو التطبيق على معلومات مهمة حول حقوقك ومسؤولياتك أو فوائدك. من الأهمية أن تفهم المعلومات الواردة في هذا المستند أو التطبيق. سوف نقدم المعلومات بلغتك المفضلة دون أي تكلفة عليك. إذا كنت في حاجة إليها، يرجى الاتصال بنا على cc@boston.gov أو 617-635-3850.

Russian:

ВАЖНО! В этом документе или заявлении содержится **важная информация** о ваших правах, обязанностях и/или льготах. Для нас очень важно, чтобы вы понимали приведенную в этом документе и/или заявлении информацию, и мы готовы бесплатно предоставить вам информацию на предпочитаемом вами языке. Если Вам они нужны, просьба связаться с нами по адресу электронной почты cc@boston.gov, либо по телефону 617-635-3850.

Portuguese:

IMPORTANTE! Este documento ou aplicativo contém **Informações importantes** sobre os seus direitos, responsabilidades e/ou benefícios. É importante que você compreenda as informações contidas neste documento e/ou aplicativo, e nós iremos fornecer as informações em seu idioma de preferência sem nenhum custo para você. Se precisar deles, fale conosco: cc@boston.gov ou 617-635-3850.

French:

IMPORTANT ! Ce document ou cette demande contient des **informations importantes** concernant vos droits, responsabilités et/ou avantages. Il est essentiel que vous compreniez les informations contenues dans ce document et/ou cette demande, que nous pouvons vous communiquer gratuitement dans la langue de votre choix. Si vous en avez besoin, veuillez nous contacter à cc@boston.gov ou au 617-635-3850.





City of Boston
Environment



City of Boston
Mayor Martin J. Walsh

**AFFIDAVIT OF SERVICE
FOR ABUTTER NOTIFICATION**

**Under the Massachusetts Wetlands Protection Act
and Boston Wetlands Ordinance**

I, Brian Timm, PE, hereby certify under pains and penalties of perjury that that at least one week prior to the public hearing, I gave notice to abutters in compliance with the second paragraph of Massachusetts General Laws Chapter 131, section 40, and the DEP Guide to Abutter Notification dated April 8, 1994, in connection with the following matter:

A Notice of Intent was filed under the Massachusetts Wetlands Protection Act and/or the Boston Wetlands Ordinance by 839 Saratoga St, LLC for Demolition of an existing building and construction of a multi-family residential building and associated parking and appurtenances. located at 839 Saratoga St, East Boston, Ma.

The Abutter Notification For, the list of abutters to whom it was given, and their addresses are attached to this Affidavit of Service.

Brian Timm

Name

2/16/2021

Date

BOSTON 300' BUFFER



FIGUREOA DAVID
864 SARATOGA ST
EAST BOSTON MA 02128

DELLO IACONO BRUNO V TS
862 SARATOGA ST
EAST BOSTON MA 02128

DEMEMO CLEMENTINA
860 SARATOGA ST
EAST BOSTON MA 02128

SALAZAR ALBERTO ALARCON
858 SARATOGA ST
EAST BOSTON MA 02128

WALSH MICHAEL E
856 SARATOGA ST
EAST BOSTON MA 02128

PICCIRILLO RALPH ETAL
7 VIDEHA ST
PEABODY MA 01960

ISAZA FABIO
701 BENNINGTON ST #2
EAST BOSTON MA 02128

GOMEZ ALBEIRO
850 SARATOGA ST
EAST BOSTON MA 02128

GOMEZ ALBEIRO
850 SARATOGA ST
EAST BOSTON MA 02128

PERROTTA LAWRENCE E
842 SARATOGA ST
EAST BOSTON MA 02128

PERROTTA LAWRENCE E
842 SARATOGA ST
EAST BOSTON MA 02128

VERRO CARL J
834 SARATOGA ST
EAST BOSTON MA 02128

INTNATL ASSOC MACHINISTS
830 SARATOGA
EAST BOSTON MA 02128

BULGROUP COLORADO LLC
224 12 TH AV C/O CP BURKE
NEW YORK NY 10001

MESA PEDRO
822 SARATOGA ST
EAST BOSTON MA 02128

MESA PEDRO
822 SARATOGA ST
EAST BOSTON MA 02128

JIMENEZ EVELYN M
820 SARATOGA ST
EAST BOSTON MA 02128

MANFRA ERNEST E
4 JEFFERSON DR
REVERE MA 02151

816 SARATOGA STREET REALTY
816 SARATOGA ST #1
EAST BOSTON MA 02128

HERRERA NELSON E
814 SARATOGA ST
EAST BOSTON MA 02128

GILLIAN BUNSHAFT ANDERSON
PO BOX 443
EAST BOSTON MA 02128

MAYA CECILIA
804-808 SARATOGA ST
EAST BOSTON MA 02128

MAYA CECILIA
804-808 SARATOGA ST
EAST BOSTON MA 02128

MAYA CECILIA
96 WORDSWORTH ST
EAST BOSTON MA 02128

EAST BOSTON NEIGHBORHOOD
155 ADDISON ST
EAST BOSTON MA 02128

SIX-61- 665 BENNINGTON ST
661 BENNINGTON ST
EAST BOSTON MA 02128

LAMBERTI GABRIELLE
371-373 DORCHESTER ST #1
SOUTH BOSTON MA 02127

BENZINE SERVICES LLC
661 BENNINGTON ST #661-2
E BOSTON MA 02128

KLOSS GERARDO
661 BENNINGTON ST #661-3
EAST BOSTON MA 02128

BENZINE SERVICES LLC
663 BENNINGTON ST #663-1
E BOSTON MA 02128

NICHOL DAVID A
663 BENNINGTON ST #663-2
E BOSTON MA 02128

KENNEY LAURA J
663 BENNINGTON ST #3
E BOSTON MA 02128

BENZINE SERVICES LLC
665 BENNINGTON ST #665-1
E BOSTON MA 02128

BENZINE SERVICES LLC
665 BENNINGTON ST #665-2
E BOSTON MA 02128

BENZINE SERVICES LLC
665 BENNINGTON ST #665-3
E BOSTON MA 02128

SEPULVEDA YENY M
669 BENNINGTON ST
EAST BOSTON MA 02128

NIJSSEN SHAUN
673 BENNINGTON ST
EAST BOSTON MA 02128

DONATELLI PAULINE LT
675 BENNINGTON ST
EAST BOSTON MA 02128

SCIMONE GASPAR
443 OAK ST
WESTWOOD MA 02090

SPENCER GLENN
681 BENNINGTON ST
EAST BOSTON MA 02128

POMODORO GUIDO M
683 BENNINGTON ST
EAST BOSTON MA 02128

POMODORO GUIDO M
683 BENNINGTON ST
EAST BOSTON MA 02128

PATINO NODIER N
687 BENNINGTON ST
EAST BOSTON MA 02128

ABRAMS PHILIP
77 MASON TERRACE APT 43
BROOKLINE MA 02446

FIORE ANNA MARIE
691 BENNINGTON ST
EAST BOSTON MA 02128

FIORE ANNA MARIE
691 R BENNINGTON ST
EAST BOSTON MA 02128

DELEO ACHILLE
693 BENNINGTON
EAST BOSTON MA 02128

695 BENNINGTON STREET REALTY
80 ASHLEY ST
EAST BOSTON MA 02128

FIORINO JOSEPH ETAL
697 BENNINGTON
EAST BOSTON MA 02128

ISAZA FABIO
699 BENNINGTON ST
EAST BOSTON MA 02128

ISAZA FABIO J
701 BENNINGTON ST
EAST BOSTON MA 02128

VASQUEZ LOUIS A
246 WALNUT AVE
REVERE MA 02151

ALEX HARRY
705 BENNINGTON ST
E BOSTON MA 02128

ORTEZ EDDIL D
61 SARATOGA ST
EAST BOSTON MA 02128

SALESIAN SOCIETY
WESTBROOK
EAST BOSTON MA 02128

ONE-48 HORACE ST CONDO
148 HORACE ST
E BOSTON MA 02128

STECKLOFF JENNIFER S
148 HORACE ST # 1
EAST BOSTON MA 02128

DELIA LAURIE
148 HORACE ST # 2
EAST BOSTON MA 02128

BODDY PAUL T JR
148 HORACE ST # 3
EAST BOSTON MA 02128

815 SARATOGA SERIES UNDER
7 TOMAH DRIVE
PEABODY MA 01960

BARRERA BONIFACIO
819 SARATOGA ST
E BOSTON MA 02128

SUMMA ROBERT P
821 SARATOGA ST
EAST BOSTON MA 02128

PICCA PROPERTIES LLC
7 TOMAH DR
PEABODY MA 01960

SARATOGA J C FAMILY LP
23 BAYSWATER ST
EAST BOSTON MA 02128

PINEDA LETICIA
827 SARATOGA ST
E BOSTON MA 02128

TETZAGUIC HILDA
668 BENNINGTON ST
E BOSTON MA 02128

VELEZ LINA MARIA
829 SARATOGA ST #1
EAST BOSTON MA 02128

CONTRERAS JAEN
831 SARATOGA ST
EAST BOSTON MA 02128

RICUPERO JOSEPH M
1216 BENNINGTON ST
E BOSTON MA 02128

HINDE ALAN J
264 SALEM ST
MEDFORD MA 02155

SAVIANO MARK W
839 SARATOGA ST
EAST BOSTON MA 02128

EIGHT41 SARATOGA ST CONDO TR
841 SARATOGA ST
EAST BOSTON MA 02128

RILLAHAN BRIAN
841 SARATOGA ST #1
EAST BOSTON MA 02128

GALDAMEZ ROXANA E
841 SARATOGA ST #2
E BOSTON MA 02128

BUONOPANE-FESTA CARLA
841 SARATOGA ST #3
E BOSTON MA 02128

EIGHT-45 SARATOGA ST CONDO
154 BROADWAY
SOMERVILLE MA 02145

BUONOPANE ERIC
845 SARATOGA ST #1
E BOSTON MA 02128

ACCORSINI SCOTT
845 SARATOGA ST #2
EAST BOSTON MA 02128

ALLRED RICHARD J
845 SARATOGA ST #3
E BOSTON MA 02128

EIGHT49 SARATOGA ST CONDO TR
5 HIGH ST
MEDFORD MA 02155

BARRERA MARIO A
849 SARATOGA ST #1
EAST BOSTON MA 02128

CHAHIBA KHADIJA
849 SARATOGA ST #2
EAST BOSTON MA 02128

TEURKIA DJILALI
849 SARATOGA ST #3
EAST BOSTON MA 02128

STEFFANO JOSEPH E JR
72 MARGINAL ST
EAST BOSTON MA 02128

WALSH MICHAEL E
853 SARATOGA ST
EAST BOSTON MA 02128

RIZZO BEVERLY J
855 SARATOGA ST
EAST BOSTON MA 02128

OSORNO DIEGO
304 BROADWAY
CAMBRIDGE MA 02139

STEFFANO RESIDENTIAL FUND II
677 SARATOGA ST
E BOSTON MA 02128

HENDERSON THOMAS F SR
861 SARATOGA ST
EAST BOSTON MA 02128

EIGHT63 SARATOGA STREET
863 SARATOGA ST
EAST BOSTON MA 02128

RANDAL ALLISON
863 SARATOGA ST #1
EAST BOSTON MA 02128

MERCADO ROLANDO
863 SARATOGA ST #2
EAST BOSTON MA 02128

DABBIERI DONNA
863 SARATOGA ST #3
EAST BOSTON MA 02128

GOODMAN KELSEY
863 SARATOGA ST #4
EAST BOSTON MA 02128

GARUFO VINCENZA
700 BENNINGTON ST
EAST BOSTON MA 02128

SCUDERI ANGELO
696 BENNINGTON ST
EAST BOSTON MA 02128

CARLSON ERIC J
692 BENNINGTON ST
EAST BOSTON MA 02128

BUSTILLO ABRAHAM
690 BENNINGTON ST
EAST BOSTON MA 02128

SHAPONICK ROBERT
688 BENNINGTON ST
EAST BOSTON MA 02128

KEITH DIANE L
686 BENNINGTON
EAST BOSTON MA 02128

LANDERGAN WILLIAM J IV
684 BENNINGTON ST
EAST BOSTON MA 02128

CAPPUCCIO MICHELA CAROLINA
682 BENNINGTON ST
E BOSTON MA 02128

PIEMONTE GAETANO G ETAL
680 BENNINGTON
EAST BOSTON MA 02128

RJ LEYDEN LLC
1956 BEACON ST
BOSTON MA 02135

PIZZI RAFFAELA R
670 BENNINGTON
EAST BOSTON MA 02128

PIZZI RAFFAELA R
670 BENNINGTON
EAST BOSTON MA 02128

PIZZI RAFFAELA R
670 BENNINGTON
EAST BOSTON MA 02128

TETZAGUIC HILDA
668 BENNINGTON ST
E BOSTON MA 02128

DOE JENNIFER A
666 BENNINGTON
EAST BOSTON MA 02128

COSTIGAN GEORGE J ETAL
664 BENNINGTON
EAST BOSTON MA 02128

NOVIELLO LUIGI ETAL
660 BENNINGTON
EAST BOSTON MA 02128

**6.0 Stormwater Report and Operation &
Maintenance Report
(UNDER SEPARATE COVER)**

7.0 Plans

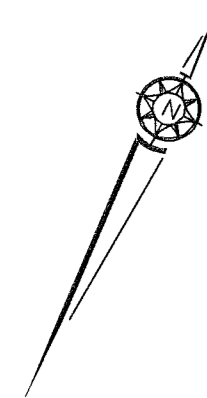

- LEGEND**
- ⊙ - SEWER MANHOLE
 - ⊕ - HYDRANT
 - ⊖ - WATER SHUT OFF
 - ⊗ - GAS SHUT OFF
 - ⊘ - WATER GATE
 - ⊙ - LIGHT POLE
 - ⊙ - ELECTRIC HANDHOLE
 - - SIGN
 - STF - STOCKADE FENCE
 - CLF - CHAIN LINK FENCE
 - TBM - TEMPORARY BENCH MARK
 - ENTR - ENTRANCE
 - VGC - VERTICAL GRANITE CURB
 - BIT - BITUMINOUS
 - CONC - CONCRETE
 - TS - TOP OF STEPS
 - TC - TOP OF CURB
 - BC - BOTTOM OF CURB
 - R= - RIM ELEVATION
 - I= - INVERT ELEVATION
 - TR= - CENTERLINE OF TROUGH
 - THR - THRESHOLD
 - FGC - FLUSH GRANITE CURB
 - UTO - UNABLE TO OPEN
 - (S) - SURVEY DIMENSION
 - (D) - DEED DIMENSION
 - (EX) - EXISTING OFFSET
 - APRX - APPROXIMATE
 - HIST - HISTORIC
 - UNGD - UNDERGROUND
 - UTO - UNABLE TO OPEN
- S - SEWER
 - W - WATER
 - G - GAS
 - E - ELECTRIC
 - T - TELEPHONE

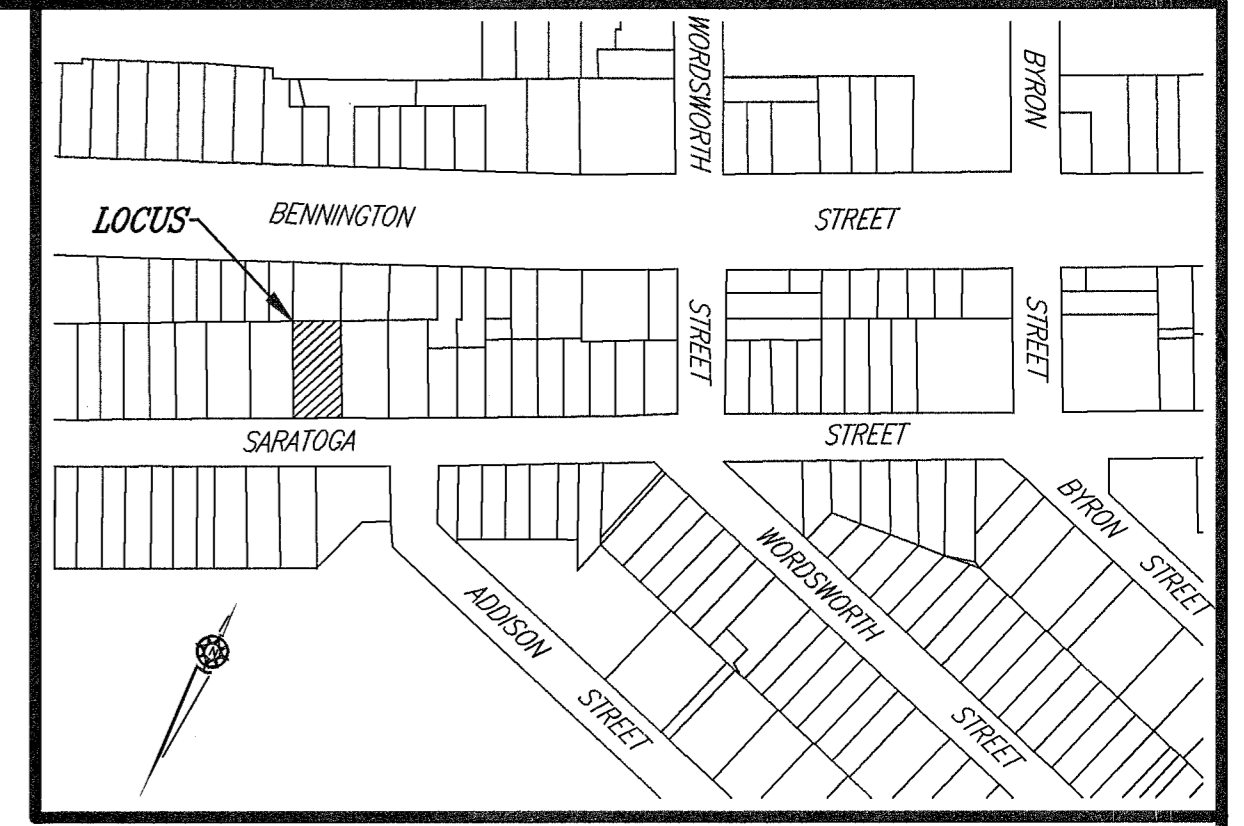
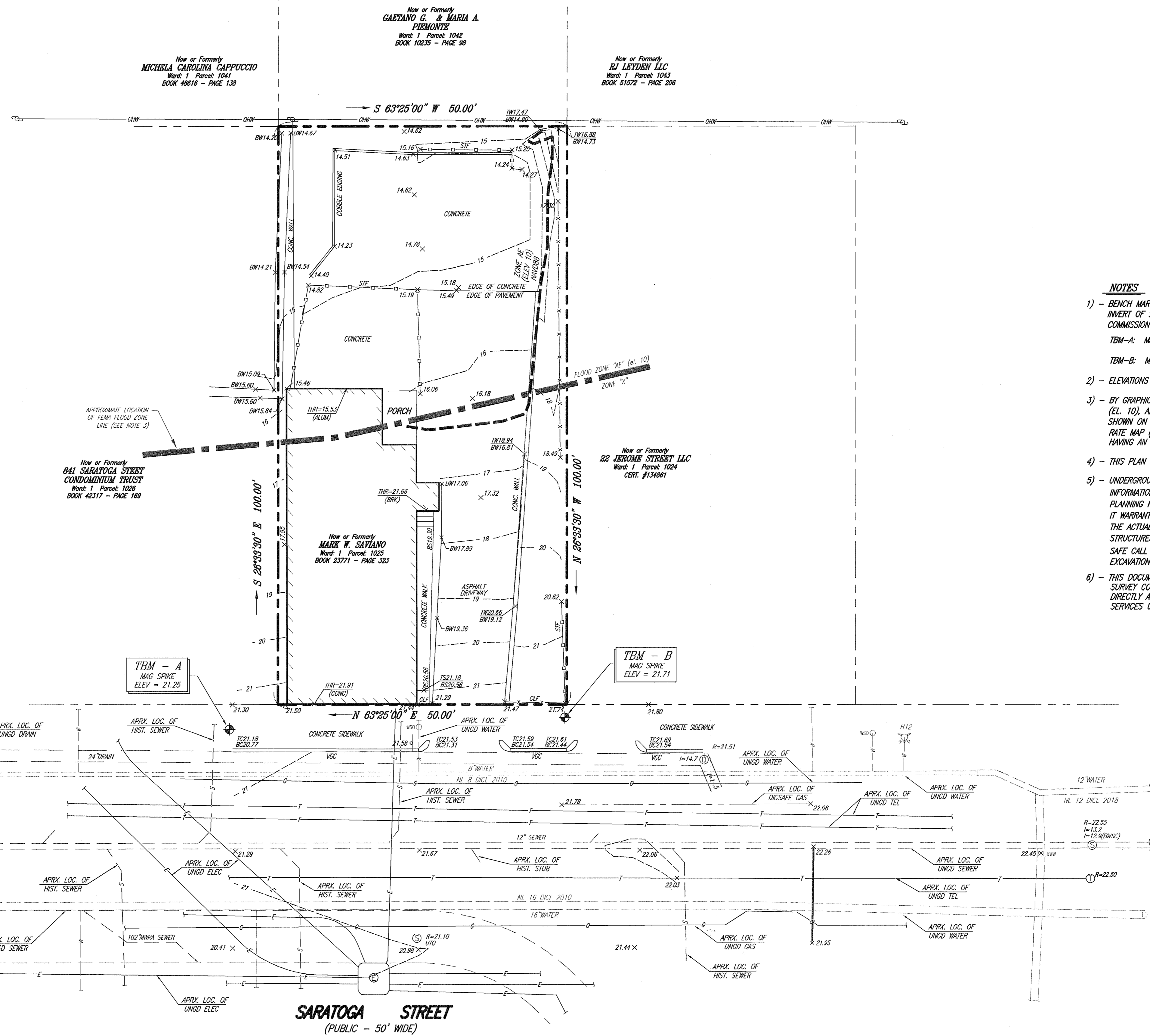

- NOTES**
- 1) - BENCH MARK USED: INVERT OF SEWER MANHOLE NO. 29 AS SHOWN ON THE BOSTON WATER AND SEWER COMMISSION PLAN. INVERT ELEVATION = 11.12
TBM-A: MAG NAIL SET IN CONCRETE SIDEWALK AS SHOWN. ELEVATION = 21.25
TBM-B: MAG NAIL SET IN CONCRETE SIDEWALK AS SHOWN. ELEVATION = 21.71
 - 2) - ELEVATIONS REFER TO BOSTON CITY BASE.
 - 3) - BY GRAPHIC PLOTTING ONLY, A PORTION OF THE PARCEL SHOWN HEREON LIES WITHIN A ZONE "AE" (EL. 10), AN AREA SUBJECT TO INUNDATION BY THE 1% ANNUAL CHANCE FLOOD, AS SHOWN ON THE FEDERAL EMERGENCY MANAGEMENT AGENCY (F.E.M.A.) FLOOD INSURANCE RATE MAP (F.I.R.M.) FOR SUFFOLK COUNTY, MASSACHUSETTS, MAP NUMBER 25025C0019, HAVING AN EFFECTIVE DATE OF MARCH 16, 2016.
 - 4) - THIS PLAN WAS PREPARED WITHOUT THE BENEFIT OF A TITLE REPORT.
 - 5) - UNDERGROUND UTILITIES SHOWN ARE FROM FIELD OBSERVATIONS AND RECORD INFORMATION AND ARE NOT WARRANTED TO BE EXACT IT'S SIZE, LOCATION, OR PLANNING FUTURE CONNECTIONS, THE PROPER UTILITY ENGINEERING DEPTH NOR IS IT WARRANTED THAT ALL UNDERGROUND DEPARTMENT SHOULD BE CONSULTED AND THE ACTUAL LOCATION OF PIPES OR STRUCTURES ARE SHOWN. SUB-SURFACE STRUCTURES SHOULD BE DETERMINED IN THE FIELD. CALL, TOLL FREE, THE DIG SAFE CALL CENTER AT 1-888-344-7233 SEVENTY TWO HOURS PRIOR TO EXCAVATION.
 - 6) - THIS DOCUMENT IS AN INSTRUMENT OF SERVICE OF FRAMINGHAM SURVEY CONSULTANTS ISSUED TO OUR CLIENT FOR PURPOSES RELATED DIRECTLY AND SOLELY TO FRAMINGHAM SURVEY CONSULTANTS SCOPE OF SERVICES UNDER CONTRACT TO OUR CLIENT FOR THIS PROJECT.

I CERTIFY THAT THIS PLAN IS BASED ON AN ACTUAL FIELD SURVEY, PLANS AND DEEDS OF RECORD.

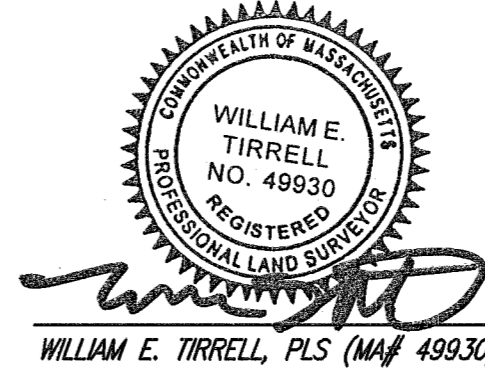

WILLIAM E. TIRRELL, PLS (MA# 49930) DATE 2/17/21

TOPOGRAPHIC PLAN
839 SARATOGA STREET
BOSTON, MASSACHUSETTS

FRAMINGHAM SURVEY CONSULTANTS INC.
P.O. BOX 1190 FRAMINGHAM, MA 01701
PH: 508-628-1444 FAX: 508-879-9292
WWW.FRAMINGHAMSURVEY.COM

SCALE: 1"=10'	DRAWN BY: RON	DWG: 839A_19
DATE: SEPTEMBER 30, 2019	CHECKED BY: WET	JOB NO: 839A_19

GRAPHIC SCALE (IN FEET)

IN ASSOCIATION WITH NEPONSET VALLEY SURVEY ASSOCIATES, INC.

ADMINISTRATIVE INFORMATION

OWNER & APPLICANT INFORMATION:
 OWNER: MARK W. SAVIANO, 839 SARATOGA STREET, EAST BOSTON, MA 02128
 APPLICANT: 839 SARATOGA STREET, LLC, ATTN: RICHARD BELVEAU, PO BOX 638, WINCHESTER, MA 01890, TEL: (860) 559-0245

SITE INFORMATION:
 ADDRESS: 839 SARATOGA STREET, EAST BOSTON, MA 02128-1115
 WARD / PARCEL: WARD 01, PARCEL: 01025000
 LAND USE CODE: R2 (EXISTING) / CD (PROPOSED)
 COBUCS RECORD NO.: 1609426971905

WATER & SEWER DATA:
 * EXISTING WATER ACCOUNT NUMBER: 1336202
 * EXISTING WATER METER NUMBER: 04016933
 * EXISTING WATER METER SIZE: 5/8"
 * PROPOSED WATER METER SIZE: 1"
 EXISTING DAILY SEWER FLOW: 550 GPD (BASED UPON 310 CMR 15.000 - 5 BEDROOMS @ 110 GPD/BEDROOM)
 ESTIMATED PROPOSED DAILY SEWER FLOW: 2,090 GPD (BASED UPON 310 CMR 15.000 - 19 BEDROOMS @ 110 GPD/BEDROOM)

GENERAL NOTES

- THE PURPOSE OF THIS PLAN IS TO DEPICT PROPOSED SITE IMPROVEMENTS ON THE LOCUS PROPERTY INCLUDING, BUT NOT LIMITED TO THE CONSTRUCTION OF A MULTI-STORY BUILDING, AND INSTALLATION OF NEW DOMESTIC WATER LINE, FIRE PROTECTION LINE, NEW SEWER SERVICE, AND A NEW ONSITE SUBSURFACE DRAINAGE SYSTEM.
- CONSTRUCTION BASELINE STATION 0+00 IS ESTABLISHED AT THE HYDRANT LOCATED IN FRONT OF 833 SARATOGA STREET.
- THE EXISTING CONDITIONS DEPICTED ON THIS PLAN ARE BASED UPON A PLAN PREPARED BY FRAMINGHAM SURVEY CONSULTANTS INC. ENTITLED "TOPOGRAPHIC PLAN - 839 SARATOGA ST. BOSTON, MA" DATED SEPTEMBER 30, 2019. ELEVATIONS DEPICTED ON THIS PLAN ARE REPORTED TO BE ON THE BOSTON CITY BASE VERTICAL DATUM.
- THE PARCEL SHOWN IS LOCATED IN ZONE X AND ZONE AE, AS SHOWN ON "FLOOD INSURANCE RATE MAP, SUFFOLK COUNTY, MASSACHUSETTS" PANEL 19 OF 176, MAP NUMBER 25025C0019J, EFFECTIVE DATE MARCH 16, 2016.
- THE LOCATION AND ELEVATIONS OF EXISTING UTILITIES AND STRUCTURES AS SHOWN ON THESE PLANS ARE BASED ON RECORDS OF VARIOUS UTILITY COMPANIES AND PUBLIC AGENCIES AND ARE APPROXIMATE ONLY. THIS INFORMATION IS NOT TO BE RELIED UPON AS BEING EXACT OR COMPLETE. THE LOCATION OF UNDERGROUND UTILITIES AND STRUCTURES SHALL BE VERIFIED IN THE FIELD BY THE CONTRACTOR PRIOR TO THE START OF CONSTRUCTION. THE CONTRACTOR MUST CONTACT THE APPROPRIATE UTILITY COMPANY, GOVERNING PERMITTING AUTHORITY AND "DIG SAFE" AT 1-888-344-7233 AT LEAST SEVENTY-TWO (72) HOURS (EXCLUDING WEEKENDS AND HOLIDAYS) PRIOR TO ANY EXCAVATION WORK TO REQUEST EXACT FIELD LOCATIONS OF UTILITIES. IF ANY DISCREPANCIES OR CONFLICTS ARE DISCOVERED, THE ENGINEER SHALL BE CONTACTED AND APPROPRIATE REMEDIAL ACTION TAKEN BEFORE PROCEEDING WITH THE WORK. IT SHALL BE THE RESPONSIBILITY OF THE CONTRACTOR TO RELOCATE ALL EXISTING UTILITIES WHICH CONFLICT WITH THE PROPOSED IMPROVEMENTS SHOWN ON THE PLANS.
- ANY DEWATERING ASSOCIATED WITH CONSTRUCTION ACTIVITIES MUST FIRST OBTAIN A DEWATERING DRAINAGE PERMIT FROM THE BWSO. SUCH DISCHARGES SHALL COMPLY WITH THE BWSO, U.S. EPA, MWRA AND OTHER APPROPRIATE AGENCIES. UNDER NO CIRCUMSTANCES SHALL DEWATERING DRAINAGE BE DISCHARGED INTO A SANITARY SEWER.
- RESTORATION OF ROADWAY AND SIDEWALK SHALL BE IN ACCORDANCE WITH BWSO CONSTRUCTION STANDARDS AND SPECIFICATIONS.
- ALL FITTINGS SHALL BE ANCHORED BY MECHANICAL MEANS OR BY CONCRETE THRUST BLOCKS, OR BOTH IF REQUIRED BY THE BWSO.
- ALL WATER, SEWER, AND DRAIN PIPE WORK LOCATED WITHIN TEN (10) FEET OF BUILDING WALL SHALL BE INSTALLED BY A LICENSED PLUMBER. SEE BUILDING PLUMBING PLANS FOR DETAILS.
- ALL BUILDING SEWER AND BUILDING STORM DRAIN INSTALLATION, REPAIR, OR MAINTENANCE WORK SHALL BE PERFORMED BY A DRAIN LAYER POSSESSING A VALID DRAIN LAYERS LICENSE ISSUED BY THE BWSO.
- THE FINISHED FLOOR ELEVATION (FFE) IS TO BE HIGHER THAN ANY ADJACENT PUBLIC SIDEWALK.
- BUILDING STORM DRAIN SHALL BE SOLID WALL, POLYVINYLCHLORIDE (PVC) PIPE, SDR 35 CONFORMING TO ASTM D3034 UNLESS NOTED OTHERWISE. NEW WATER SERVICES SHALL BE TYPE K COPPER.

COMPENSATORY FLOOD STORAGE ANALYSIS

ELEVATION (FT, FCB)	INCREMENTAL VOLUME OF FILL (CUBIC FEET)	INCREMENTAL VOLUME OF CUT (CUBIC FEET)	PROPOSED OFFSET (CUBIC FEET)
16.00-16.46 (100-YEAR FLOODPLAIN ELEVATION)	1,029	1,174	145
15.00-16.00	1,529	1,605	76
14.00-15.00	324	427	103
13.00-14.00	0	7	7
TOTAL	2,882	3,213	331

PLAN LEGEND

GAS VALVE		PROPOSED CORPORATION STOP/TAPPING SLEEVE AND VALVE	
HYDRANT		PROPOSED DOORENTRY	
CATCH BASIN		PROPOSED FOUNDATION	
WATER VALVE		PROPOSED OVERHANG/STORIES ABOVE	
DRAIN MANHOLE		PROPOSED SUBSURFACE INFILTRATION SYSTEM	
SEWER MANHOLE		PROPOSED RETAINING WALL	
UTILITY POLE		PROPOSED DRAIN LINE	
SPOT ELEVATION	x35.8	PROPOSED FIRE SERVICE	
VERTICAL GRANITE CURB RECORD (REC)		PROPOSED WATER SERVICE	
SEWER LINE		PROPOSED SEWER SERVICE	
WATER LINE		PROPOSED CONTOUR	
DRAIN LINE		PROPOSED RIM	
GAS LINE		PROPOSED INVERT	
TREE		PROPOSED CATCH BASIN	
CONTOUR		PROPOSED DOWN SPOUT	
100-YR FLOOD ZONE LIMIT RECORD (REC)		PROPOSED SEWER CLEANOUT	
		PROPOSED SPOT GRADE	
		PROPOSED DRAIN BASIN	
		PROPOSED TOP AND BOTTOM WALL ELEV.	
		LANDSCAPED AREA	
		PROPOSED COLUMN	
		FINISHED FLOOR ELEVATION	
		EDGE OF PAVEMENT	

INSPECTION SIGN-OFF SCHEDULE

ITEM NO.	DESCRIPTION	QTY.	BWSO INSPECTOR / DATE	COMMENTS
A	ZINC COATED 6" DUCTILE IRON (CLASS 50) FIRE PIPE W/ TAPPING SLEEVE AND VALVE	1		
B	INSTALL 1" WATER METER	1		
C	2" COPPER TYPE K DOMESTIC WATER SERVICE AND CORP. STOP	1		
D	6" PVC SDR35 SEWER SERVICE	1		
E	PROPOSED SEWER CLEANOUT	1		
F	DEEP SUMP CATCH BASIN W/ OIL TRAP (CB-1)	1		
G	PROPOSED SUBSURFACE INFILTRATION SYSTEM 4' X (4' X 4' LEACHING GALLEYS)	1		
H	CONNECT ALL PROPOSED ROOF DRAINS TO SUBSURFACE INFILTRATION SYSTEM	1		
I	DYE TEST NEW SEWER SERVICE	1		
J	CUT AND CAP EXISTING WATER SERVICE; REMOVE EXISTING WATER GATE AND ROADWAY BOX	1		
K	RETURN EXISTING 1/2" WATER METER TO BWSO	1		
L	CUT AND CAP EXISTING SEWER SERVICE	1		
M	AS-BUILT PREPARATION FEE			

FOR BWSO USE ONLY

SIZING OF DRAINAGE SYSTEM

QUANTITY OF PROPOSED ONSITE IMPERVIOUS SURFACES (SF)

SITE FEATURE	AREA (SF)
BUILDING(S)	3,282 SF
DRIVEWAYS, WALKWAYS(S) & PATIOS(S)	1,415 SF
GRASSED AREA / LANDSCAPING:	303 SF
TOTAL IMPERVIOUS AREA ONSITE:	4,997 SF
(EXCLUDES PERMEABLE PAVER SURFACES)	

REQUIRED STORAGE VOLUME (1-INCH OVER TOTAL IMPERVIOUS AREA) (CF)

= (1-INCH) X (1 FOOT/12 INCHES) X (IMPERVIOUS AREA)
 = (1-INCH) X (1 FOOT/12 INCHES) X (4,997 SF)
 = 391 CF

VOLUME CALCULATION FOR SUBSURFACE INFILTRATION SYSTEM (CF)

VOLUME WITHIN DRYWELL(S)
 = (INSIDE LENGTH) X (INSIDE WIDTH) X (INSIDE HEIGHT) X (NO. CHAMBERS)
 = (3.5 FT) X (3.5 FT) X (3.67 FT) X 4 CH
 = 179 CF

VOLUME OF VOIDS IN STONE SURROUNDING DRYWELL (ASSUME 30% VOID RATIO)
 = TOTAL VOLUME OF EXCAVATION
 = (10 FT WIDE) X (20 FT LONG) X (5.2 FT DEEP)
 = 1,040 CF

-EXTERIOR VOLUME OF DRYWELL
 = (EXTERIOR WIDTH) X (EXTERIOR LENGTH) X (EXTERIOR HEIGHT) X (NO.)
 = (4.0 FT) X (4.0 FT) X (4.2 FT) X 4 CH
 = 269 CF

-TOTAL VOLUME OF STONE
 = VOLUME OF EXCAVATION - EXTERIOR VOLUME OF DRYWELL
 = 1,040 CF - 269 CF
 = 771 CF

-TOTAL VOLUME OF STONE VOIDS (30%)
 = 771 CF X 0.3
 = 231 CF

TOTAL VOLUME PROVIDED IN SUBSURFACE INFILTRATION SYSTEM:
 = DRYWELL VOLUME + VOID IN STONE VOLUME
 = 179 CF + 231 CF
 = 410 CF

410 CF (PROVIDED) > 391 CF (REQUIRED)

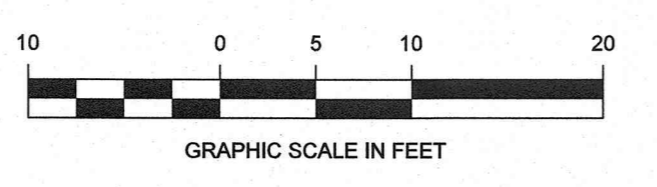
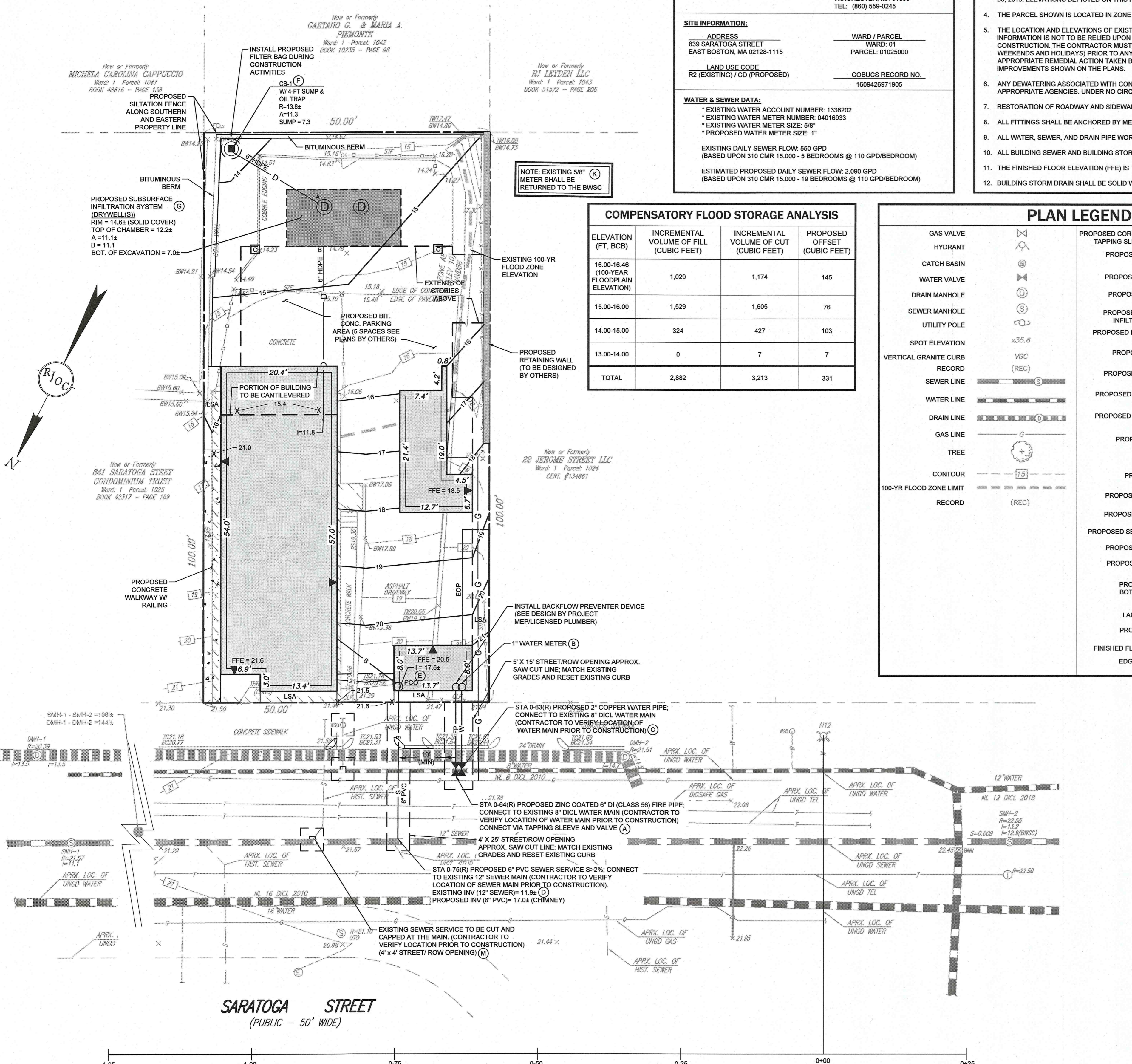

DATE	REVISION	NO.

PREPARED BY:
RJO'CONNELL & ASSOCIATES, INC.
 CIVIL ENGINEERS, SURVEYORS & LAND PLANNERS
 80 MONTVALE AVENUE, SUITE 201 STONEHAM, MA 02180
 PHONE: 781.279.0180 RJOCONNELL.COM

PREPARED FOR:
839 SARATOGA STREET LLC.
 PO BOX 638
 WINCHESTER, MA 01890

PROJECT NAME:
839 SARATOGA STREET
 BOSTON, MA

DESIGNED BY: TRG/CMM
 DRAWN BY: CMM
 REVIEWED BY: BWT
 SCALE: 1" = 10'
 DATE: 02/18/2021
 DRAWING NAME:

GRADING AND DRAINAGE PLAN

DRAWING NUMBER: **C-1**
 PROJECT NUMBER: **20155**

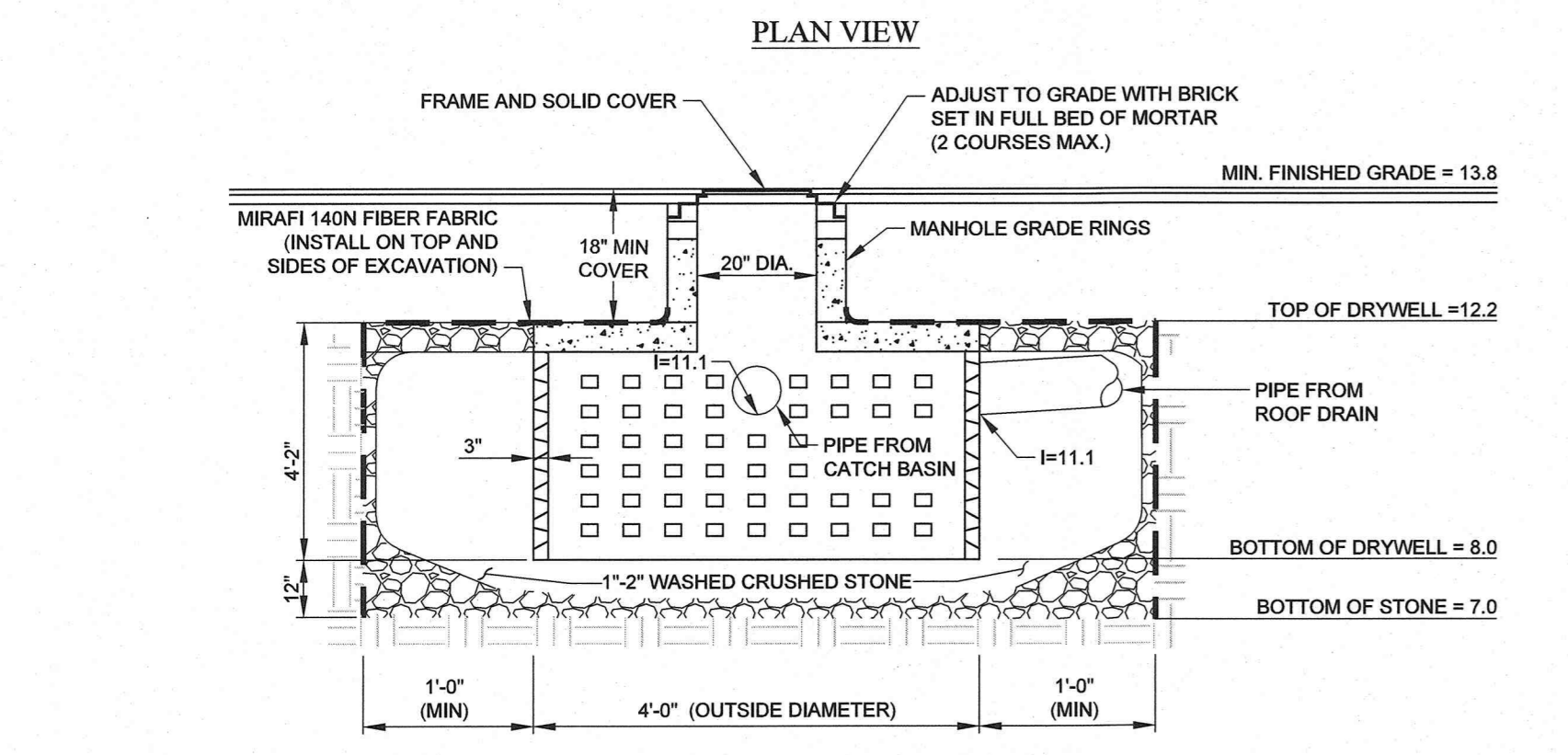
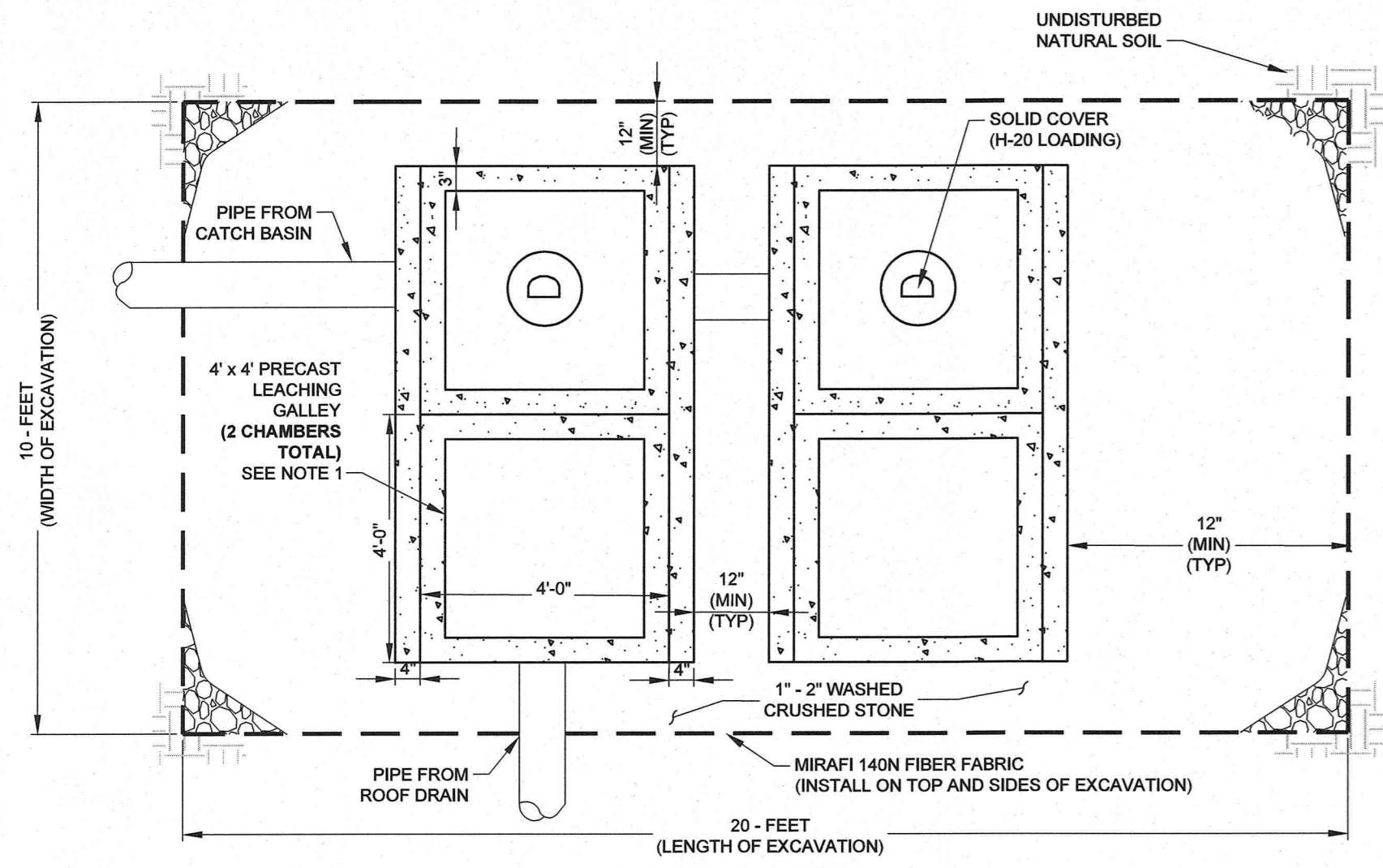

- GENERAL NOTES**
1. PRECAST STRUCTURE SHALL BE 4' x 4' LEACHING GALLEY AS MANUFACTURED BY SCITUATE COMPANIES OR APPROVED EQUAL.
 2. STRUCTURE AND COVER SHALL BE DESIGNED FOR H-20 LOADING.
 3. CONCRETE SHALL BE 5000 PSI AFTER 28 DAYS.

4' x 4' LEACHING GALLEYS - (4 GALLEYS TOTAL)
SCALE: N.T.S.

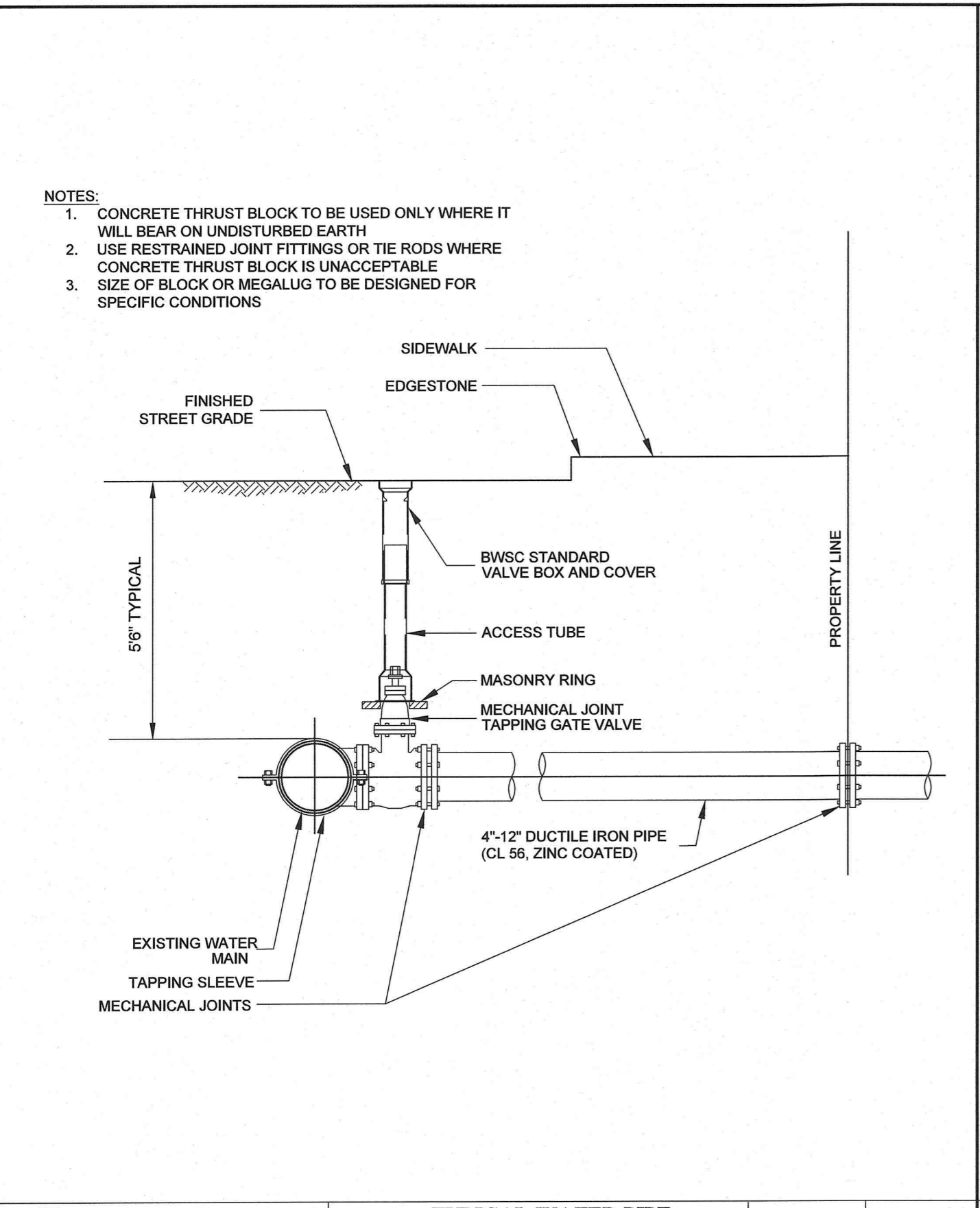

TYPICAL WATER PIPE CONNECTION WITH TAPPING SLEEVE AND GATE VALVE
SCALE: Not To Scale
DATE: June 30, 2012
DETAIL NO. A-09

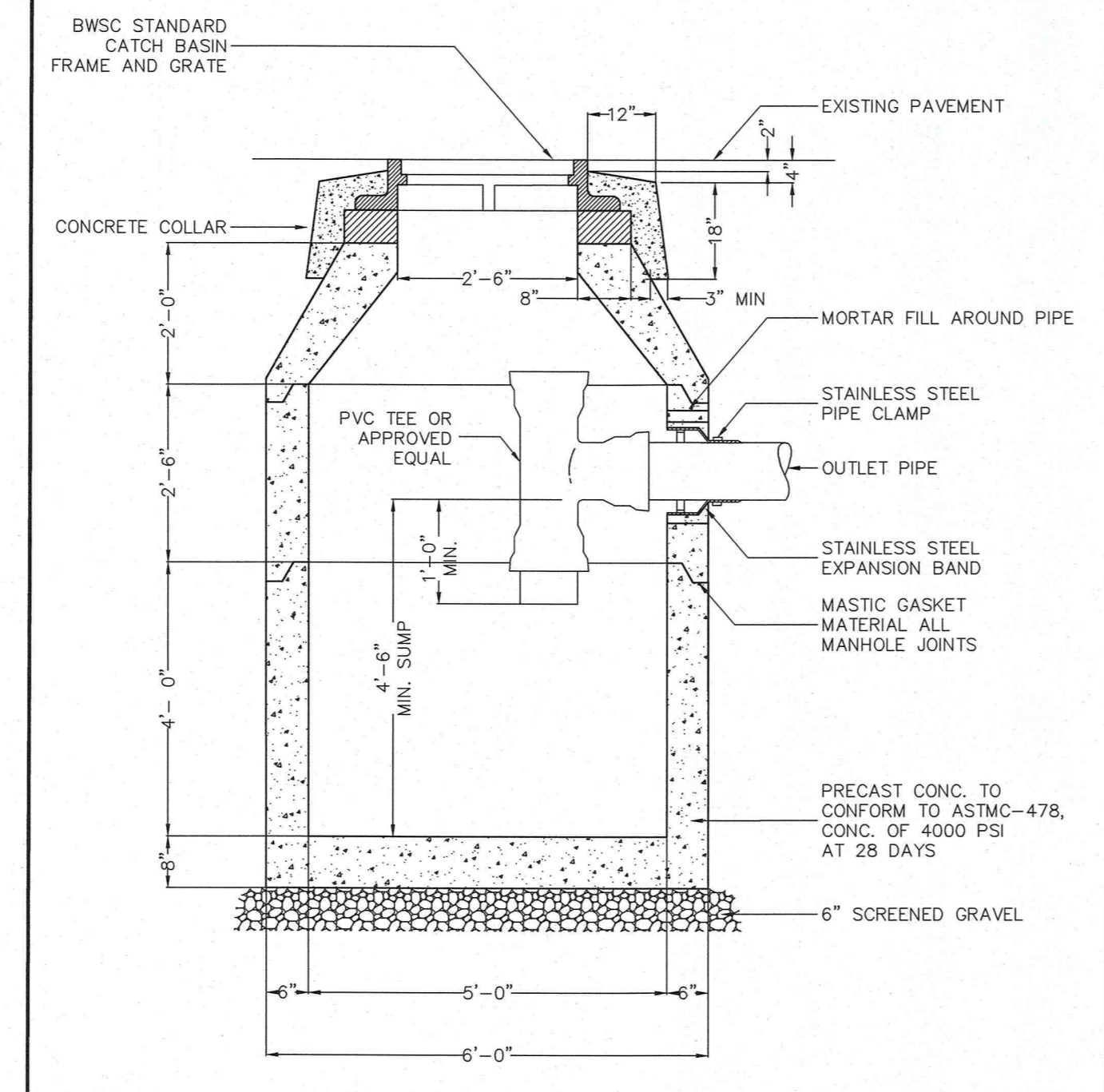

CATCH BASIN WITH OIL TRAP OUTLET
SCALE: Not To Scale
DATE: June 30, 2012
DETAIL NO. B-01g

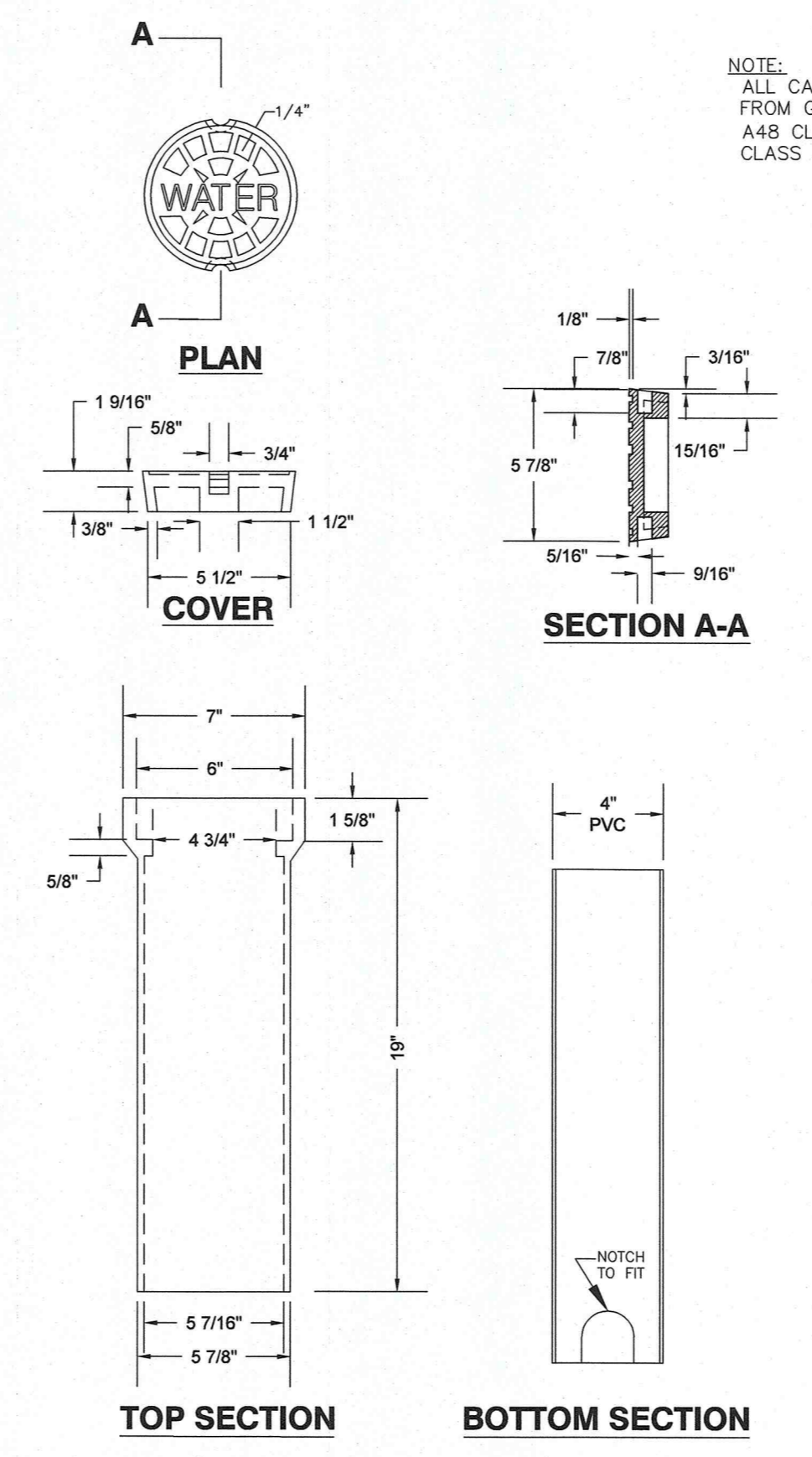

WATER SERVICE ROADWAY BOX
SCALE: Not To Scale
DATE: NOV 20, 2014
DETAIL NO. F2-09

- NOTE:**
1. BITUMINOUS CONCRETE FOR CURBING SHALL BE CLASS I CONFORMING TO THE APPLICABLE REQUIREMENTS FOR DENSE MIX IN SECTION M3.11.03, TABLE A OF THE MASSDOT STANDARD SPECIFICATIONS FOR HIGHWAYS AND BRIDGES.
 2. THE BITUMINOUS CONCRETE MIXTURE SHALL BE PLACED AND COMPACTED WITH A MACHINE CAPABLE OF SPREADING THE MIXTURE TRUE TO LINE AND GRADE AND TO THE SHAPE STIPULATED.
 3. IF AT ANY TIME BEFORE ACCEPTANCE OF THE WORK ANY SOFT OR IMPERFECT SPOTS DEVELOP IN THE EXPOSED SURFACE OF THE CURB, THAT PORTION OF THE CURB SHALL BE REMOVED AND REPLACED WITH NEW CURBING AT NO COST TO THE OWNER.

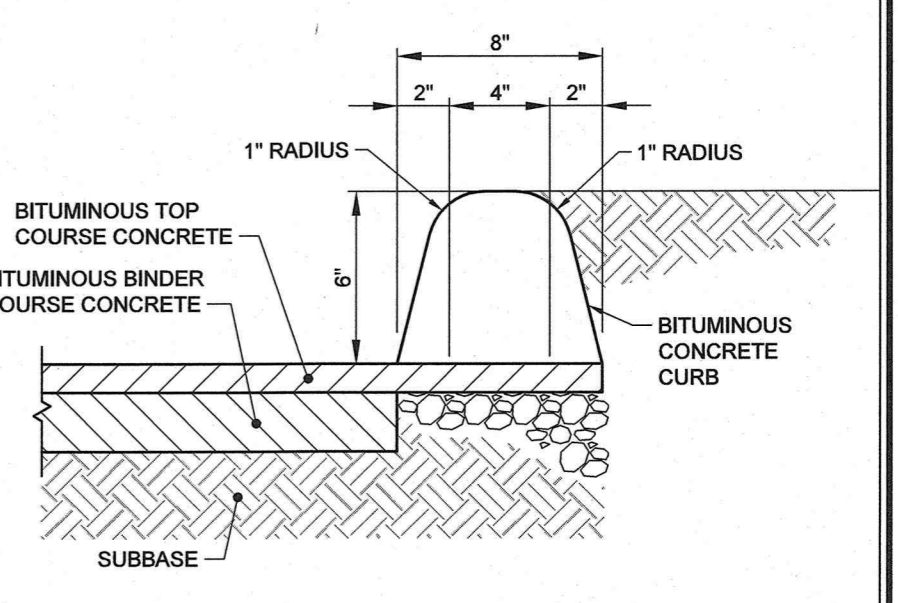

BITUMINOUS CONCRETE CURB DETAIL
SCALE: N.T.S.

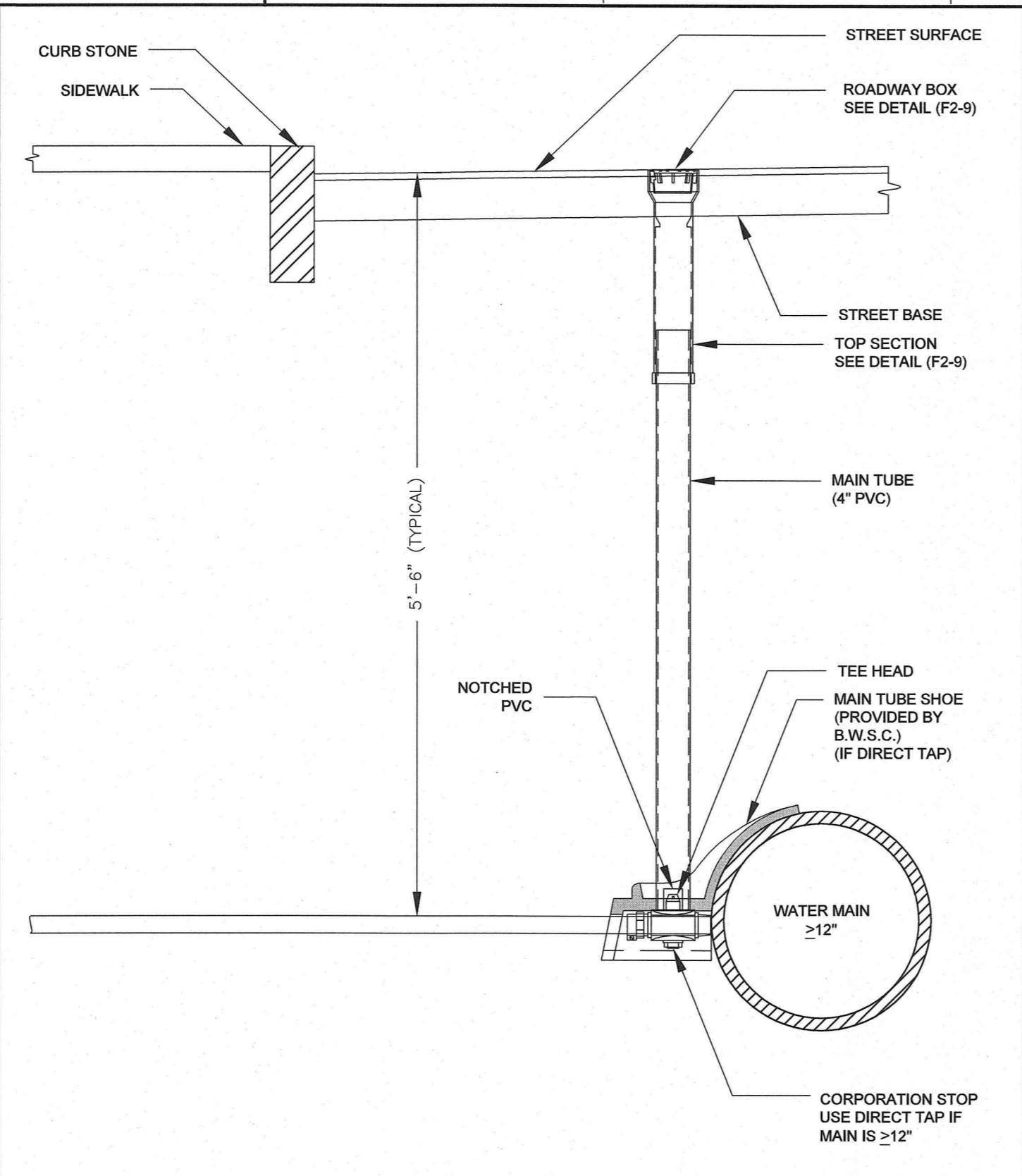

TYPICAL WATER CONNECTION FOR 1-1/2 AND 2-INCH SERVICE PIPES TO 12-16\"/>

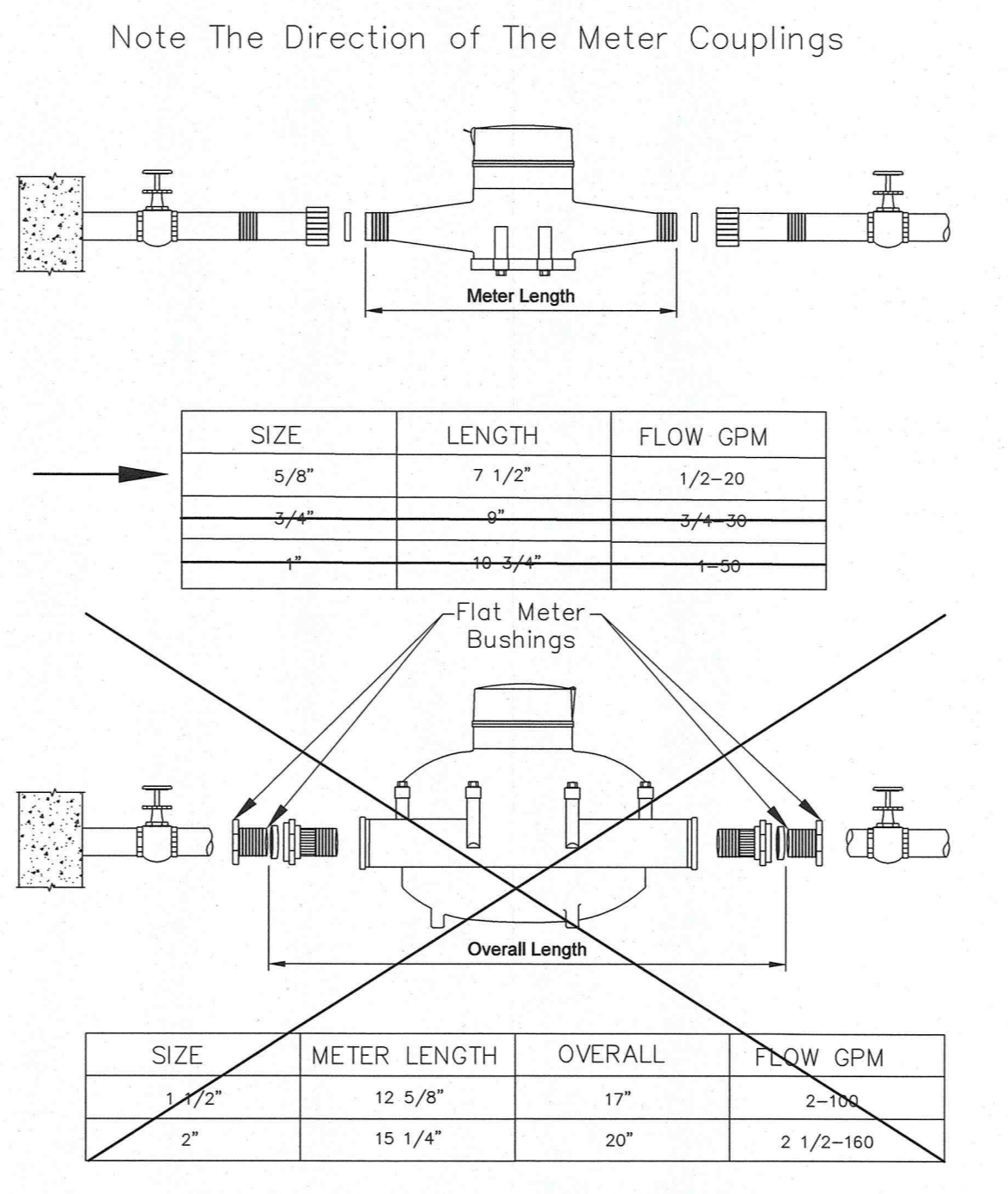

INSTALLATION OF WATER METERS (5/8\"/>

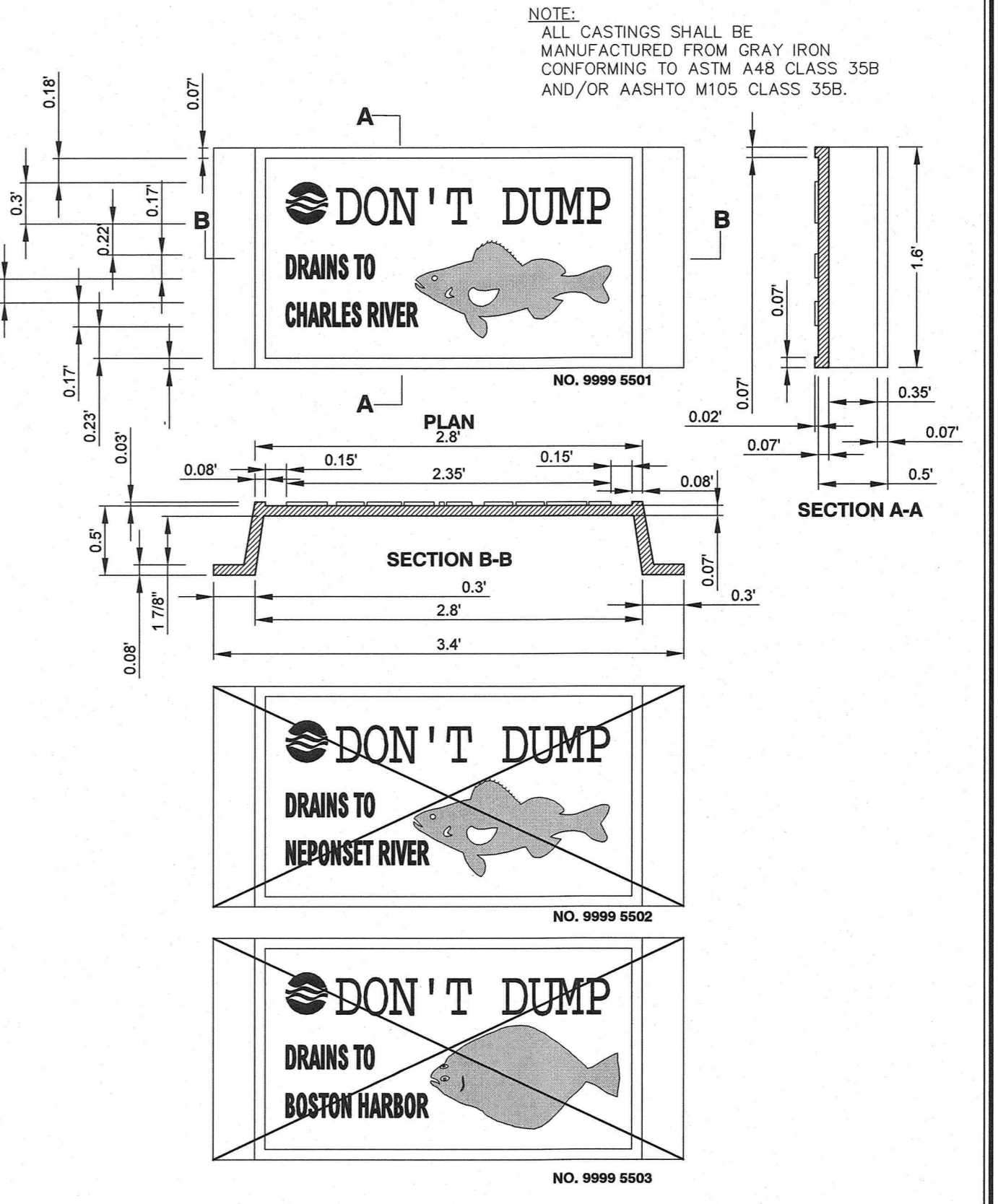

8X14 CATCH BASIN SIGN
SCALE: Not To Scale
DATE: JAN. 17, 2014
DETAIL NO. F1-D23

NO.	DATE	REVISION

PREPARED BY:
RJO'CONNELL & ASSOCIATES, INC.
CIVIL ENGINEERS, SURVEYORS & LAND PLANNERS
80 MONTVALE AVENUE, SUITE 201 STONEHAM, MA 02180
PHONE: 781.279.0180 RJOCONNELL.COM

PREPARED FOR:
839 SARATOGA STREET LLC.
PO BOX 638
WINCHESTER, MA 01890

PROJECT NAME:
839 SARATOGA STREET
BOSTON, MA

DESIGNED BY: CMM
DRAWN BY: CMM/MCR
REVIEWED BY: BWT
SCALE: N.T.S.
DATE: 02/16/2021
DRAWING NAME:

DETAILS I

DRAWING NUMBER:
C-2
PROJECT NUMBER:
20155

NO.	DATE	REVISION

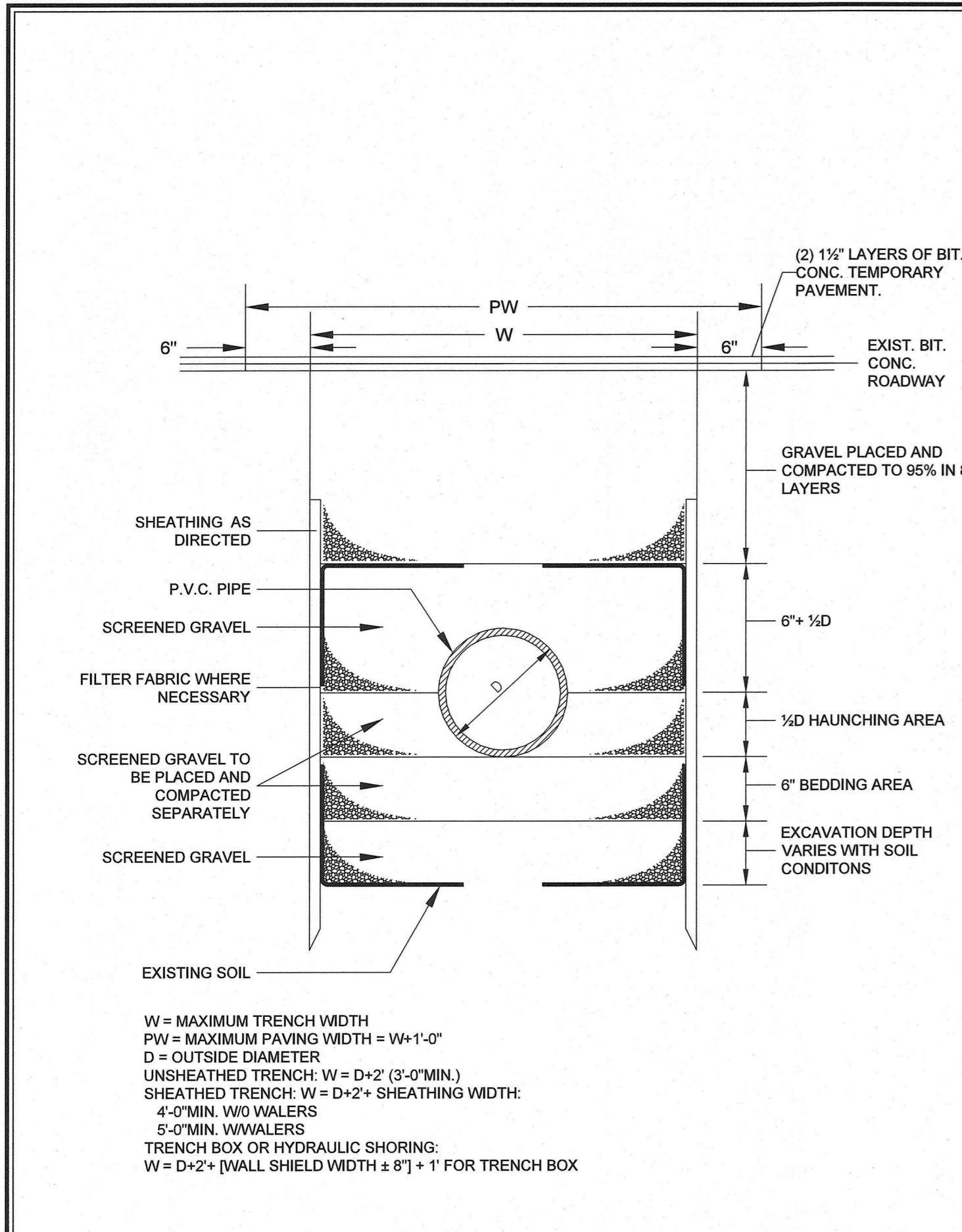

Boston Water and Sewer Commission
 800 HARRISON AVE., BOSTON, MA 02119
 (617) 889-7000 www.bwsc.org

TRENCH DETAIL FOR PVC PIPE
 Scale: Not To Scale

DATE: June 30, 2012
 DETAIL NO. B-09

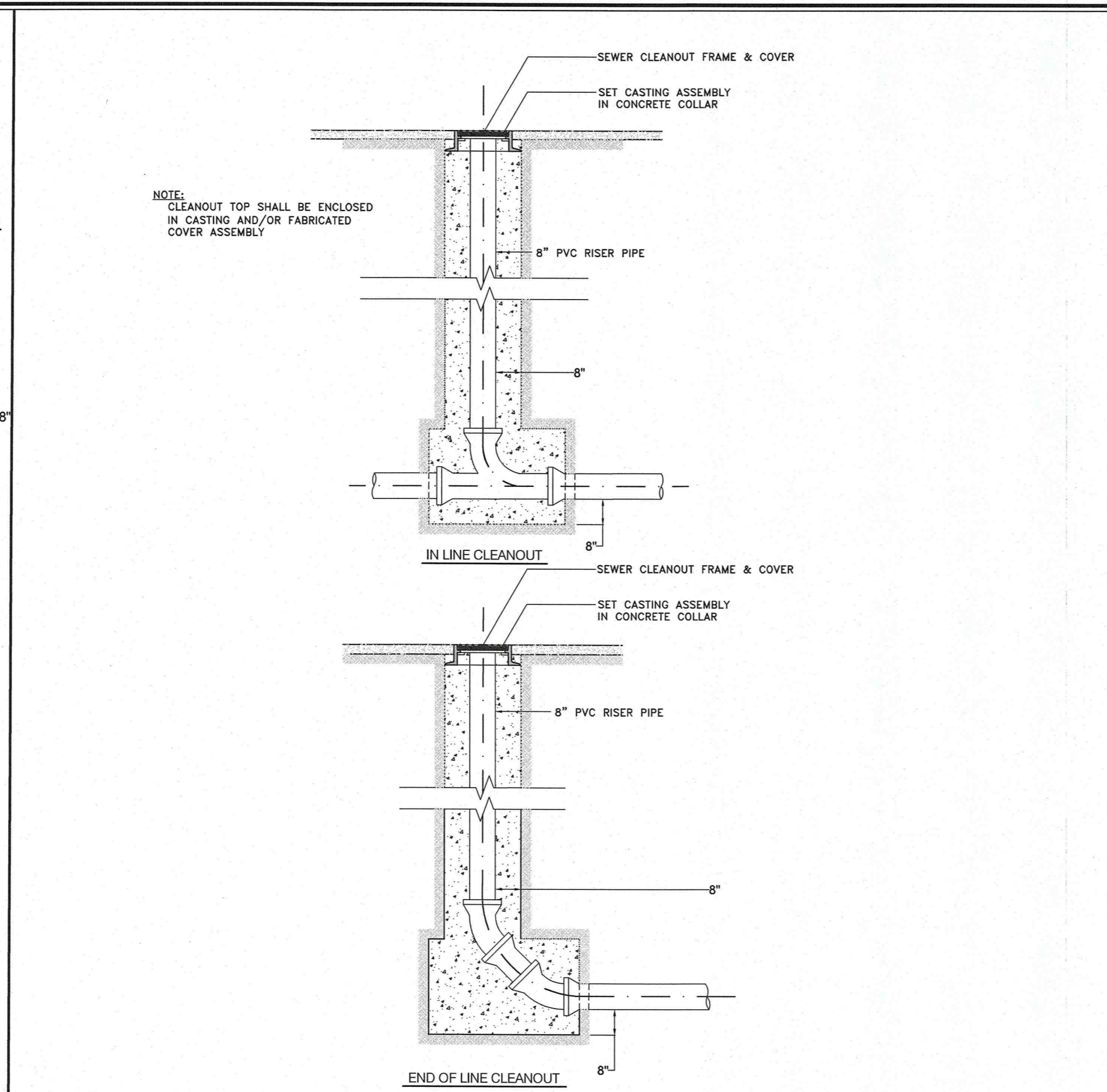

Boston Water and Sewer Commission
 800 HARRISON AVE., BOSTON, MA 02119
 (617) 889-7000 www.bwsc.org

WYE CLEANOUT
 Scale: Not To Scale

DATE: Sept. 30, 2012
 DETAIL NO. B-17

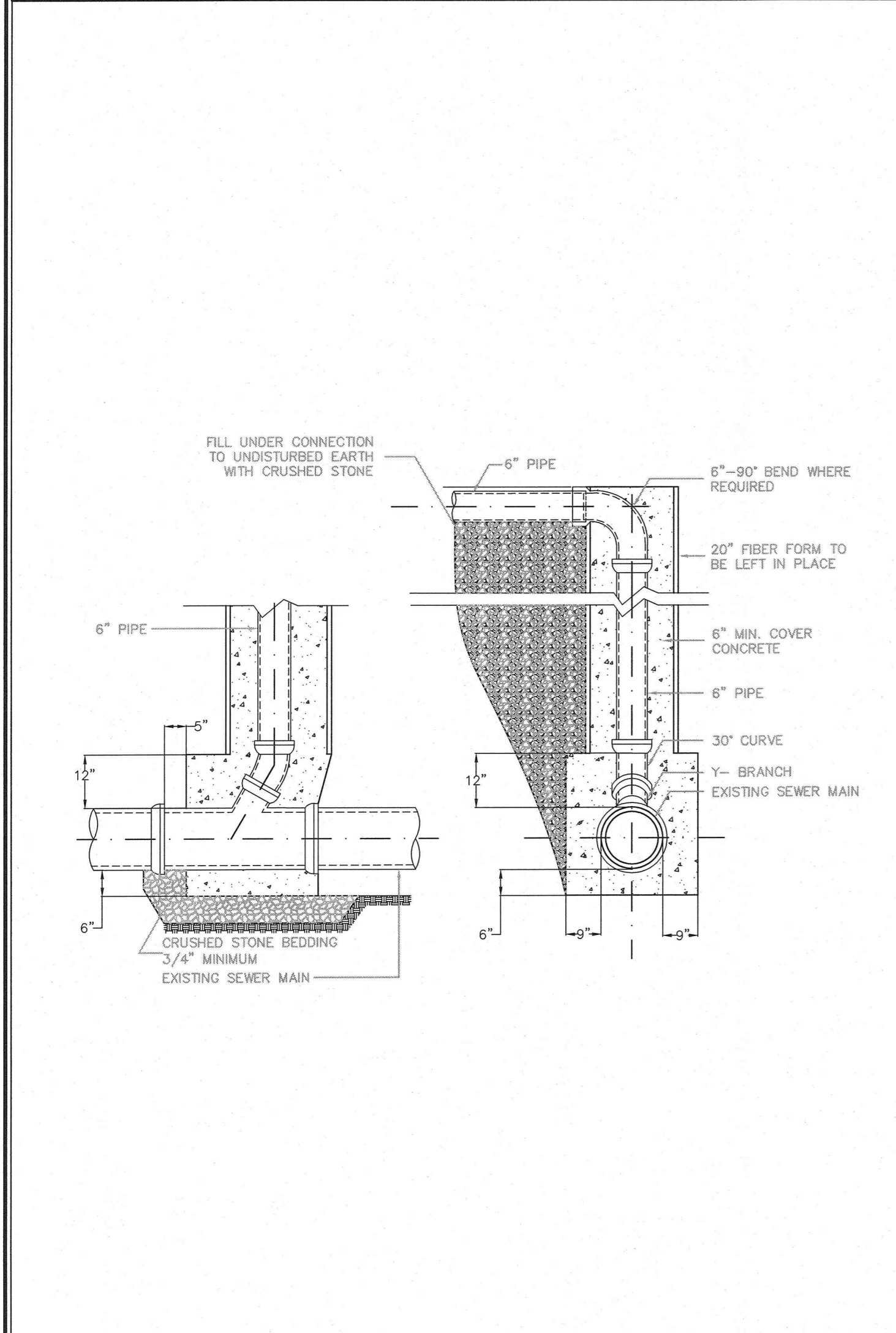

Boston Water and Sewer Commission
 800 HARRISON AVE., BOSTON, MA 02119
 (617) 889-7000 www.bwsc.org

TYPICAL SEWER CHIMNEY
 Scale: Not To Scale

DATE: Sept. 30, 2012
 DETAIL NO. B-15

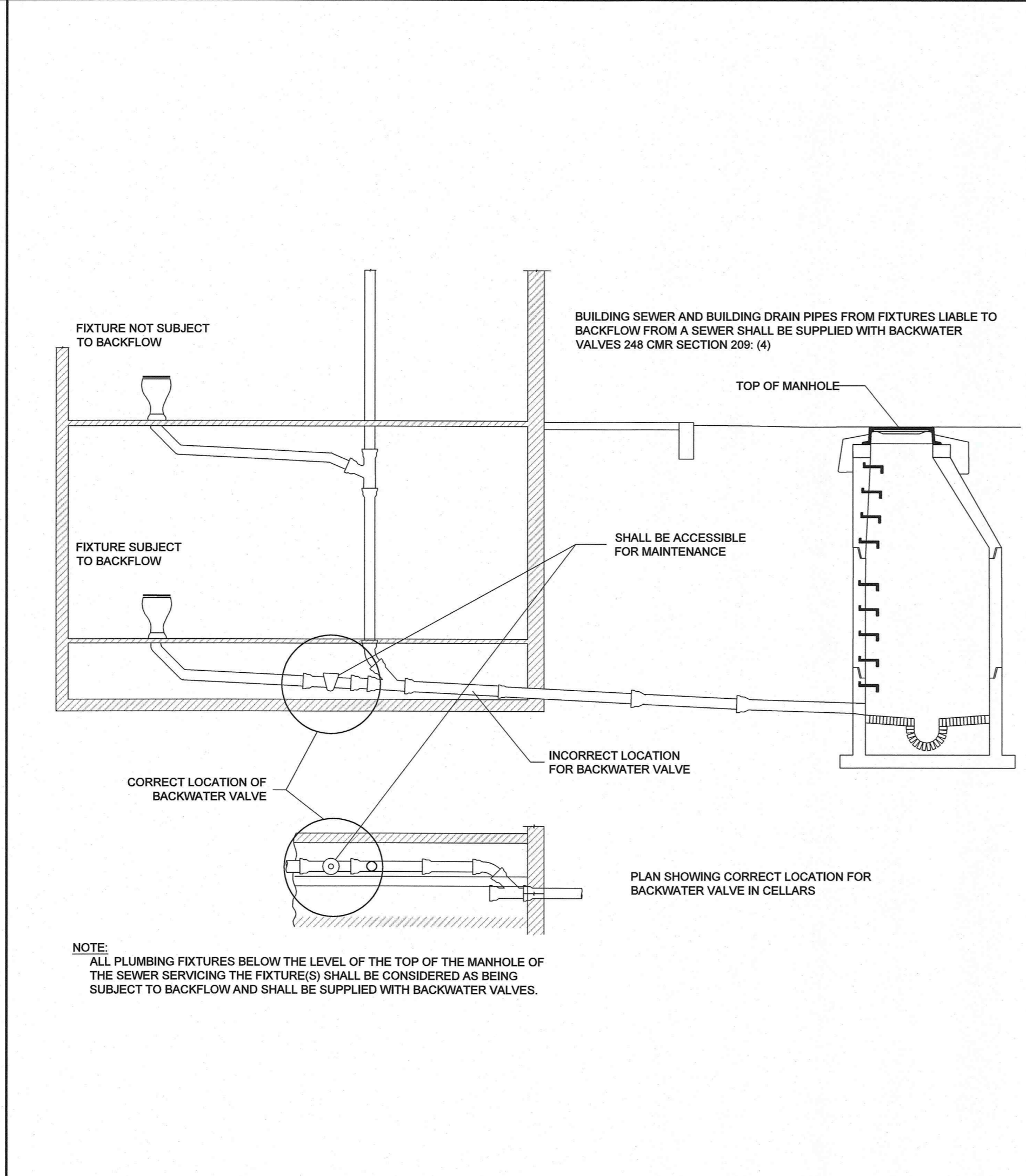

Boston Water and Sewer Commission
 800 HARRISON AVE., BOSTON, MA 02119
 (617) 889-7000 www.bwsc.org

LOCATION OF BACKWATER VALVES IN CELLARS
 Scale: Not To Scale

DATE: Sept. 30, 2012
 DETAIL NO. B-14

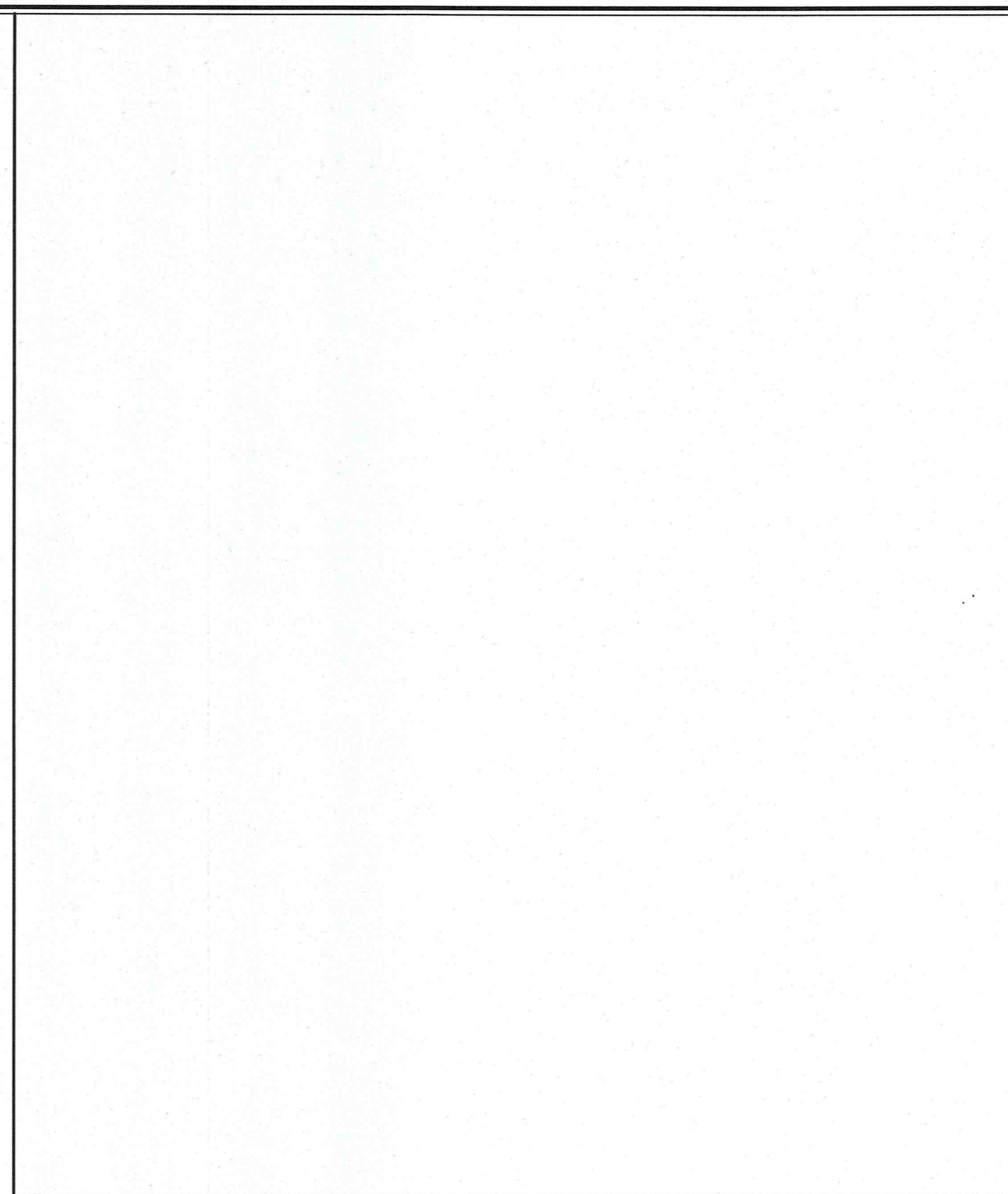

TYPICAL SILTATION FENCE DETAIL
 SCALE: N.T.S.

NOTES:
 1. IN AREAS WHERE ANCHOR TRENCH CANNOT BE DUG, FABRIC WILL BE LAID ON SURFACE AND COVERED WITH 6\"/>

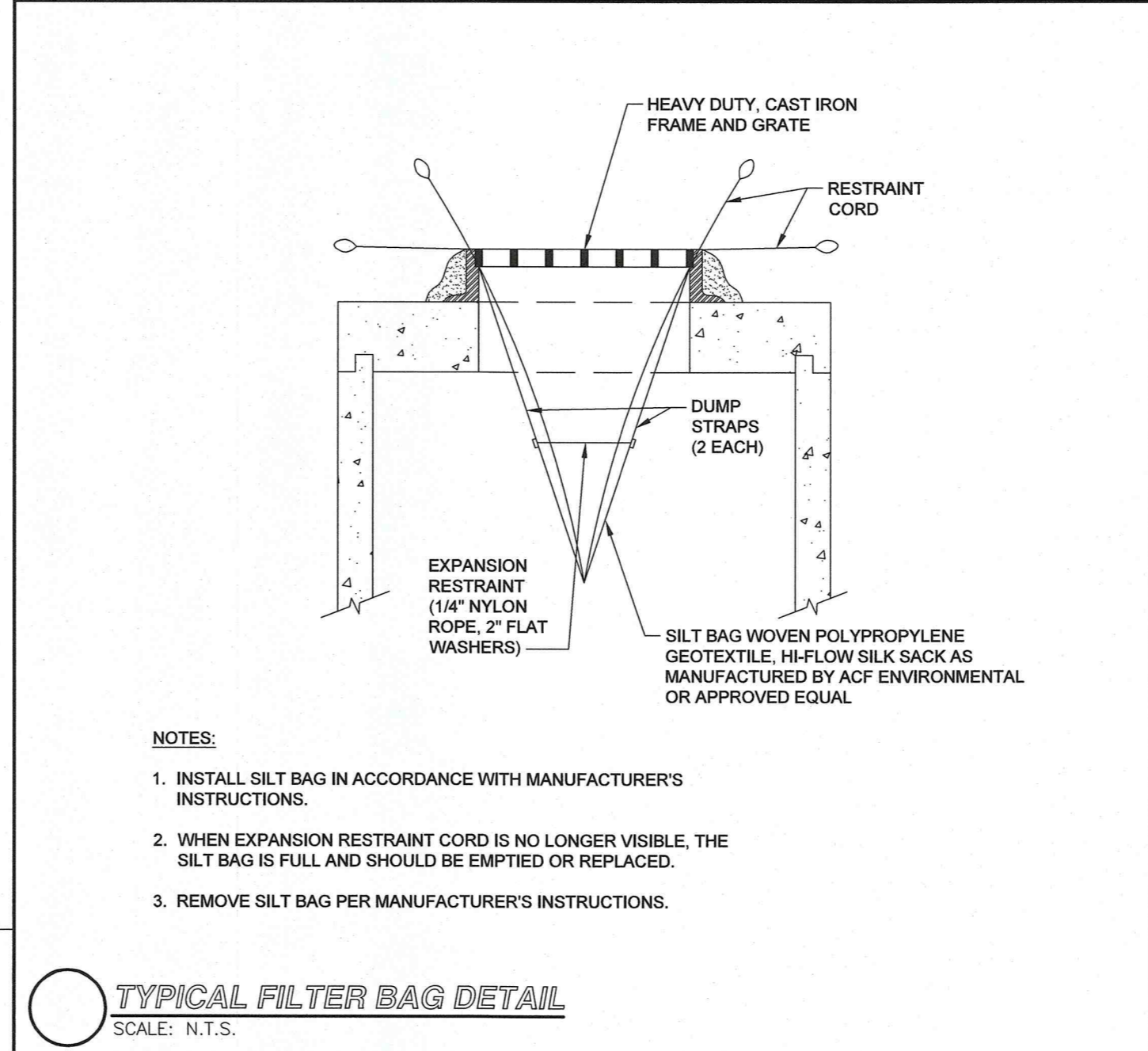

TYPICAL FILTER BAG DETAIL
 SCALE: N.T.S.

NOTES:
 1. INSTALL SILT BAG IN ACCORDANCE WITH MANUFACTURER'S INSTRUCTIONS.
 2. WHEN EXPANSION RESTRAINT CORD IS NO LONGER VISIBLE, THE SILT BAG IS FULL AND SHOULD BE EMPTIED OR REPLACED.
 3. REMOVE SILT BAG PER MANUFACTURER'S INSTRUCTIONS.

PREPARED BY:
RJO'CONNELL & ASSOCIATES, INC.
 CIVIL ENGINEERS, SURVEYORS & LAND PLANNERS
 80 MONTVALE AVENUE, SUITE 201 STONEHAM, MA 02180
 PHONE: 781.279.0180 RJOCONNELL.COM

PREPARED FOR:
839 SARATOGA STREET LLC.
 PO BOX 638
 WINCHESTER, MA 01890

PROJECT NAME:
839 SARATOGA STREET
 BOSTON, MA

SEAL:

 BRIAN W. TIMM
 No. 45120
 CIVIL
 PROFESSIONAL ENGINEER
 State of Massachusetts

DESIGNED BY: CMM
 DRAWN BY: CMM/MCR
 REVIEWED BY: BWT
 SCALE: N.T.S.
 DATE: 02/16/2021
 DRAWING NAME:

DETAILS I

DRAWING NUMBER:
C-3

PROJECT NUMBER:
 20155

Drawing name: G:\MA\Boston\Volney Capital\839 Saratoga Street\Main\20155 C-3 Details.dwg
 Feb 16, 2021 - 16:07pm

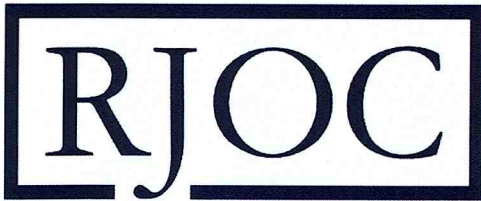

Stormwater Management Report

**839 Saratoga Street
Cambridge, Massachusetts**

**Prepared for:
839 Saratoga St., LLC
PO Box 638
Winchester, MA 01890**

**Prepared by:
R.J. O'Connell & Associates, Inc.
80 Montvale Ave, Suite 201
Stoneham, Massachusetts 02180**

**Date:
February 16, 2021**

Revised: N/A



Table of Contents

I. Drainage Analysis Narrative

II. Forms and Computations

Appendix A Checklist for Stormwater Report

Appendix B HydroCAD Hydrological Computations

III. Operation and Maintenance Plan (O&M)

I. Drainage Analysis Narrative

RJO'CONNELL & ASSOCIATES, INC.

CIVIL ENGINEERS, SURVEYORS & LAND PLANNERS

80 Montvale Ave., Suite 201
phone 781-279-0180

Stoneham, MA 02180
fax 781-279-0173

February 16, 2021

Mr. Nicholas Moreno
& Members of the Boston Conservation Commission
Conservation Agent
Boston City Hall Room 709
Boston, MA 02201

Re: 839 Saratoga Street
Boston, MA

Dear Mr. Moreno & Members of the Boston Conservation Commission:

On behalf of the Applicant and Owner of the above referenced property, RJ O'Connell & Associates, Inc. (RJOC) is respectfully submitting this letter, plan, and drainage calculations for your review and approval in reference to the project proposed at 839 Saratoga Street in Boston, MA. In accordance with the City of Boston drainage requirements, RJOC has designed a proposed stormwater management system that will mitigate the increase in rate of stormwater runoff generated by the proposed development. The components of the proposed stormwater management system and their corresponding details are depicted on the attached plans entitled "Grading, Drainage, and Utility Plan", "Details I", and "Details II" as prepared by RJ O'Connell & Associates, dated 02/16/2021 (Design Plans). This letter summarizes the approach and results of the drainage analysis and design depicted on the Design Plans. As the calculations will demonstrate, the Post-Development rate of stormwater runoff flowing off the site will be equal to the Pre-Development rate of stormwater runoff during the 2-Year, 10-Year, and 25-Year Design Storms.

Existing Conditions:

The existing site is sloped from Saratoga Street south towards the rear of the Site. Stormwater runoff that lands on the existing roof is collected and discharged from roof leaders to the existing driveway or landscaped areas in the back yard. Runoff that lands on the driveway is conveyed via overland flow to the rear of the lot along the southern property line where an existing low point is located.

Proposed Conditions:

Under proposed redeveloped conditions, stormwater runoff landing on the roof of the new building will be collected and discharged directly into a subsurface infiltration system. Runoff that is collected over the uncovered portion of the proposed parking area will be collected by a deep sump catch basin (with an oil trap) and conveyed to the subsurface infiltration system. The subsurface infiltration system has been sized to retain and infiltrate the first inch of runoff generated by the entire redeveloped Site (i.e., the Water Quality Volume).

Stormwater Management System:

The proposed stormwater management system is comprised of the installation of one (1) field of precast concrete leaching galleys. The field of systems will be located in the rear of the site, south of the proposed building. These leaching galleys have been designed to infiltrate one-inch times the total onsite impervious surface, per BWSC's (Boston Water and Sewer Commission) requirement. A nominal amount of overflow will occur from these systems during the 2-Year, 24-Hour Design Storm, 10-Year, 24-Hour Design Storm, 25-Year, 24-Hour Design Storm, and 100-Year, 24-Hour Design Storm.

Summary of Rate of Runoff:

RJOC has performed a hydrologic analysis of the site under pre- and post-construction activities at the Point of Analysis). Attached to this letter are the hydrologic calculations that were performed using HydroCAD to generate the various rates of runoff summarized in the Table below. The intensity of the various design storms are based upon TP-40 as required by the Massachusetts Stormwater Management Standards. The 24-hour rainfall rates used during the 2, 10, 25 and 100-year 24-hour design storms are outlined in the Tables below.

Table 1: Peak Rate of Runoff at POA-1 (Southern Abutter)

Design Storm	Peak Rate of Runoff (cfs)		Reduction (cfs)
	Pre-Construction	Post Construction	
2-Yr, 24-Hr (3.20")	0.3	0.3	0.0 (0% reduction)
10-Yr, 24-Hr (4.60")	0.5	0.5	0.0 (0% reduction)
25-Yr, 24-Hr (5.50")	0.6	0.6	0.0 (0% reduction)
100-Yr, 24-Hr (6.60")	0.7	0.7	0.0 (0% reduction)

Recharge Volume Calculations

$R_v = \text{Target Depth Factor} \times \text{Net Increase in Impervious Area}$

$$R_v = (0.6 \text{ inches} / 12 \text{ inches}) \times 678 \text{ SF} = 40 \text{ CF}$$

Recharge Provided below Invert of SIS-1 = **351 CF**

Additional Recharge Provided in Excess of the Required Recharge Volume = **311 CF**

Total Drawdown Time = $R_v / ((\text{Saturated Hydraulic Conductivity}) * (\text{Bottom Infiltration Area}))$

$$\text{Total Drawdown Time} = 678 \text{ CF} / (((0.09 \text{ inches} / \text{hours}) / 12 \text{ inches}) * 200 \text{ SF})$$

Total Drawdown Time = 27 Hours for the Required Recharge Volume in SIS-1.

Water Quality Volume (PR-1):

$$V_{WQ} = D_{WQ} * A_{\text{impervious}}$$

Where:

D_{WQ} = Water Quality Depth = 1-inch

$A_{\text{impervious}}$ = Impervious area = 4,798 sf

$$V_{WQ} = 1.0 \text{ in} * \left(\frac{1 \text{ ft}}{12 \text{ in}} \right) * 4,798 \text{ sf} = 400 \text{ CF}$$

Conclusion

As the calculations and Tables demonstrate, the peak rate of runoff under Post Construction Conditions will be equal to that under Pre-Construction Conditions. Furthermore, stormwater collected under post conditions will provide treatment, detention, and infiltration which will improve stormwater runoff quality on site.

I anticipate this letter, calculations, and design plan will meet your expectations. Please don't hesitate to call me at 781-279-0180 with any questions or concerns. Otherwise, I look forward to receiving your approval of this proposed design.

Respectfully,

RJ O'CONNELL & ASSOCIATES

A handwritten signature in blue ink, appearing to read "Brian W. Timm", written in a cursive style.

Brian W. Timm, PE
Associate Principal

A handwritten signature in blue ink, appearing to read "Chris McDonnell", written in a cursive style.

Chris McDonnell
Staff Designer

Enclosures

cc: Richard Beliveau

II. Forms and Computations

Appendix A – Checklist for Stormwater Report



Checklist for Stormwater Report

A. Introduction

Important: When filling out forms on the computer, use only the tab key to move your cursor - do not use the return key.



A Stormwater Report must be submitted with the Notice of Intent permit application to document compliance with the Stormwater Management Standards. The following checklist is NOT a substitute for the Stormwater Report (which should provide more substantive and detailed information) but is offered here as a tool to help the applicant organize their Stormwater Management documentation for their Report and for the reviewer to assess this information in a consistent format. As noted in the Checklist, the Stormwater Report must contain the engineering computations and supporting information set forth in Volume 3 of the [Massachusetts Stormwater Handbook](#). The Stormwater Report must be prepared and certified by a Registered Professional Engineer (RPE) licensed in the Commonwealth.

The Stormwater Report must include:

- The Stormwater Checklist completed and stamped by a Registered Professional Engineer (see page 2) that certifies that the Stormwater Report contains all required submittals.¹ This Checklist is to be used as the cover for the completed Stormwater Report.
- Applicant/Project Name
- Project Address
- Name of Firm and Registered Professional Engineer that prepared the Report
- Long-Term Pollution Prevention Plan required by Standards 4-6
- Construction Period Pollution Prevention and Erosion and Sedimentation Control Plan required by Standard 8²
- Operation and Maintenance Plan required by Standard 9

In addition to all plans and supporting information, the Stormwater Report must include a brief narrative describing stormwater management practices, including environmentally sensitive site design and LID techniques, along with a diagram depicting runoff through the proposed BMP treatment train. Plans are required to show existing and proposed conditions, identify all wetland resource areas, NRCS soil types, critical areas, Land Uses with Higher Potential Pollutant Loads (LUHPPL), and any areas on the site where infiltration rate is greater than 2.4 inches per hour. The Plans shall identify the drainage areas for both existing and proposed conditions at a scale that enables verification of supporting calculations.

As noted in the Checklist, the Stormwater Management Report shall document compliance with each of the Stormwater Management Standards as provided in the Massachusetts Stormwater Handbook. The soils evaluation and calculations shall be done using the methodologies set forth in Volume 3 of the Massachusetts Stormwater Handbook.

To ensure that the Stormwater Report is complete, applicants are required to fill in the Stormwater Report Checklist by checking the box to indicate that the specified information has been included in the Stormwater Report. If any of the information specified in the checklist has not been submitted, the applicant must provide an explanation. The completed Stormwater Report Checklist and Certification must be submitted with the Stormwater Report.

¹ The Stormwater Report may also include the Illicit Discharge Compliance Statement required by Standard 10. If not included in the Stormwater Report, the Illicit Discharge Compliance Statement must be submitted prior to the discharge of stormwater runoff to the post-construction best management practices.

² For some complex projects, it may not be possible to include the Construction Period Erosion and Sedimentation Control Plan in the Stormwater Report. In that event, the issuing authority has the discretion to issue an Order of Conditions that approves the project and includes a condition requiring the proponent to submit the Construction Period Erosion and Sedimentation Control Plan before commencing any land disturbance activity on the site.



Checklist for Stormwater Report

B. Stormwater Checklist and Certification

The following checklist is intended to serve as a guide for applicants as to the elements that ordinarily need to be addressed in a complete Stormwater Report. The checklist is also intended to provide conservation commissions and other reviewing authorities with a summary of the components necessary for a comprehensive Stormwater Report that addresses the ten Stormwater Standards.

Note: Because stormwater requirements vary from project to project, it is possible that a complete Stormwater Report may not include information on some of the subjects specified in the Checklist. If it is determined that a specific item does not apply to the project under review, please note that the item is not applicable (N.A.) and provide the reasons for that determination.

A complete checklist must include the Certification set forth below signed by the Registered Professional Engineer who prepared the Stormwater Report.

Registered Professional Engineer's Certification

I have reviewed the Stormwater Report, including the soil evaluation, computations, Long-term Pollution Prevention Plan, the Construction Period Erosion and Sedimentation Control Plan (if included), the Long-term Post-Construction Operation and Maintenance Plan, the Illicit Discharge Compliance Statement (if included) and the plans showing the stormwater management system, and have determined that they have been prepared in accordance with the requirements of the Stormwater Management Standards as further elaborated by the Massachusetts Stormwater Handbook. I have also determined that the information presented in the Stormwater Checklist is accurate and that the information presented in the Stormwater Report accurately reflects conditions at the site as of the date of this permit application.

Registered Professional Engineer Block and Signature



Brian W. Timm 2/16/2021

Signature and Date

Checklist

Project Type: Is the application for new development, redevelopment, or a mix of new and redevelopment?

- New development
- Redevelopment
- Mix of New Development and Redevelopment



Checklist for Stormwater Report

Checklist (continued)

LID Measures: Stormwater Standards require LID measures to be considered. Document what environmentally sensitive design and LID Techniques were considered during the planning and design of the project:

- No disturbance to any Wetland Resource Areas
- Site Design Practices (e.g. clustered development, reduced frontage setbacks)
- Reduced Impervious Area (Redevelopment Only)
- Minimizing disturbance to existing trees and shrubs
- LID Site Design Credit Requested:
 - Credit 1
 - Credit 2
 - Credit 3
- Use of “country drainage” versus curb and gutter conveyance and pipe
- Bioretention Cells (includes Rain Gardens)
- Constructed Stormwater Wetlands (includes Gravel Wetlands designs)
- Treebox Filter
- Water Quality Swale
- Grass Channel
- Green Roof
- Other (describe): _____

Standard 1: No New Untreated Discharges

- No new untreated discharges
- Outlets have been designed so there is no erosion or scour to wetlands and waters of the Commonwealth
- Supporting calculations specified in Volume 3 of the Massachusetts Stormwater Handbook included.



Checklist for Stormwater Report

Checklist (continued)

Standard 2: Peak Rate Attenuation

- Standard 2 waiver requested because the project is located in land subject to coastal storm flowage and stormwater discharge is to a wetland subject to coastal flooding.
- Evaluation provided to determine whether off-site flooding increases during the 100-year 24-hour storm.
- Calculations provided to show that post-development peak discharge rates do not exceed pre-development rates for the 2-year and 10-year 24-hour storms. If evaluation shows that off-site flooding increases during the 100-year 24-hour storm, calculations are also provided to show that post-development peak discharge rates do not exceed pre-development rates for the 100-year 24-hour storm.

Standard 3: Recharge

- Soil Analysis provided.
- Required Recharge Volume calculation provided.
- Required Recharge volume reduced through use of the LID site Design Credits.
- Sizing the infiltration, BMPs is based on the following method: Check the method used.
 - Static
 - Simple Dynamic
 - Dynamic Field¹
- Runoff from all impervious areas at the site discharging to the infiltration BMP.
- Runoff from all impervious areas at the site is *not* discharging to the infiltration BMP and calculations are provided showing that the drainage area contributing runoff to the infiltration BMPs is sufficient to generate the required recharge volume.
- Recharge BMPs have been sized to infiltrate the Required Recharge Volume.
- Recharge BMPs have been sized to infiltrate the Required Recharge Volume *only* to the maximum extent practicable for the following reason:
 - Site is comprised solely of C and D soils and/or bedrock at the land surface
 - M.G.L. c. 21E sites pursuant to 310 CMR 40.0000
 - Solid Waste Landfill pursuant to 310 CMR 19.000
 - Project is otherwise subject to Stormwater Management Standards only to the maximum extent practicable.
- Calculations showing that the infiltration BMPs will drain in 72 hours are provided.
- Property includes a M.G.L. c. 21E site or a solid waste landfill and a mounding analysis is included.

¹ 80% TSS removal is required prior to discharge to infiltration BMP if Dynamic Field method is used.



Checklist for Stormwater Report

Checklist (continued)

Standard 3: Recharge (continued)

- The infiltration BMP is used to attenuate peak flows during storms greater than or equal to the 10-year 24-hour storm and separation to seasonal high groundwater is less than 4 feet and a mounding analysis is provided.
- Documentation is provided showing that infiltration BMPs do not adversely impact nearby wetland resource areas.

Standard 4: Water Quality

The Long-Term Pollution Prevention Plan typically includes the following:

- Good housekeeping practices;
 - Provisions for storing materials and waste products inside or under cover;
 - Vehicle washing controls;
 - Requirements for routine inspections and maintenance of stormwater BMPs;
 - Spill prevention and response plans;
 - Provisions for maintenance of lawns, gardens, and other landscaped areas;
 - Requirements for storage and use of fertilizers, herbicides, and pesticides;
 - Pet waste management provisions;
 - Provisions for operation and management of septic systems;
 - Provisions for solid waste management;
 - Snow disposal and plowing plans relative to Wetland Resource Areas;
 - Winter Road Salt and/or Sand Use and Storage restrictions;
 - Street sweeping schedules;
 - Provisions for prevention of illicit discharges to the stormwater management system;
 - Documentation that Stormwater BMPs are designed to provide for shutdown and containment in the event of a spill or discharges to or near critical areas or from LUHPPL;
 - Training for staff or personnel involved with implementing Long-Term Pollution Prevention Plan;
 - List of Emergency contacts for implementing Long-Term Pollution Prevention Plan.
- A Long-Term Pollution Prevention Plan is attached to Stormwater Report and is included as an attachment to the Wetlands Notice of Intent.
 - Treatment BMPs subject to the 44% TSS removal pretreatment requirement and the one inch rule for calculating the water quality volume are included, and discharge:
 - is within the Zone II or Interim Wellhead Protection Area
 - is near or to other critical areas
 - is within soils with a rapid infiltration rate (greater than 2.4 inches per hour)
 - involves runoff from land uses with higher potential pollutant loads.
 - The Required Water Quality Volume is reduced through use of the LID site Design Credits.
 - Calculations documenting that the treatment train meets the 80% TSS removal requirement and, if applicable, the 44% TSS removal pretreatment requirement, are provided.



Checklist for Stormwater Report

Checklist (continued)

Standard 4: Water Quality (continued)

- The BMP is sized (and calculations provided) based on:
 - The ½" or 1" Water Quality Volume or
 - The equivalent flow rate associated with the Water Quality Volume and documentation is provided showing that the BMP treats the required water quality volume.
- The applicant proposes to use proprietary BMPs, and documentation supporting use of proprietary BMP and proposed TSS removal rate is provided. This documentation may be in the form of the propriety BMP checklist found in Volume 2, Chapter 4 of the Massachusetts Stormwater Handbook and submitting copies of the TARP Report, STEP Report, and/or other third party studies verifying performance of the proprietary BMPs.
- A TMDL exists that indicates a need to reduce pollutants other than TSS and documentation showing that the BMPs selected are consistent with the TMDL is provided.

Standard 5: Land Uses With Higher Potential Pollutant Loads (LUHPPLs)

- The NPDES Multi-Sector General Permit covers the land use and the Stormwater Pollution Prevention Plan (SWPPP) has been included with the Stormwater Report.
- The NPDES Multi-Sector General Permit covers the land use and the SWPPP will be submitted **prior to** the discharge of stormwater to the post-construction stormwater BMPs.
- The NPDES Multi-Sector General Permit does **not** cover the land use.
- LUHPPLs are located at the site and industry specific source control and pollution prevention measures have been proposed to reduce or eliminate the exposure of LUHPPLs to rain, snow, snow melt and runoff, and been included in the long term Pollution Prevention Plan.
- All exposure has been eliminated.
- All exposure has **not** been eliminated and all BMPs selected are on MassDEP LUHPPL list.
- The LUHPPL has the potential to generate runoff with moderate to higher concentrations of oil and grease (e.g. all parking lots with >1000 vehicle trips per day) and the treatment train includes an oil grit separator, a filtering bioretention area, a sand filter or equivalent.

Standard 6: Critical Areas

- The discharge is near or to a critical area and the treatment train includes only BMPs that MassDEP has approved for stormwater discharges to or near that particular class of critical area.
- Critical areas and BMPs are identified in the Stormwater Report.



Checklist for Stormwater Report

Checklist (continued)

Standard 7: Redevelopments and Other Projects Subject to the Standards only to the maximum extent practicable

- The project is subject to the Stormwater Management Standards only to the maximum Extent Practicable as a:
- Limited Project
 - Small Residential Projects: 5-9 single family houses or 5-9 units in a multi-family development provided there is no discharge that may potentially affect a critical area.
 - Small Residential Projects: 2-4 single family houses or 2-4 units in a multi-family development with a discharge to a critical area
 - Marina and/or boatyard provided the hull painting, service and maintenance areas are protected from exposure to rain, snow, snow melt and runoff
 - Bike Path and/or Foot Path
 - Redevelopment Project
 - Redevelopment portion of mix of new and redevelopment.
- Certain standards are not fully met (Standard No. 1, 8, 9, and 10 must always be fully met) and an explanation of why these standards are not met is contained in the Stormwater Report.
- The project involves redevelopment and a description of all measures that have been taken to improve existing conditions is provided in the Stormwater Report. The redevelopment checklist found in Volume 2 Chapter 3 of the Massachusetts Stormwater Handbook may be used to document that the proposed stormwater management system (a) complies with Standards 2, 3 and the pretreatment and structural BMP requirements of Standards 4-6 to the maximum extent practicable and (b) improves existing conditions.

Standard 8: Construction Period Pollution Prevention and Erosion and Sedimentation Control

A Construction Period Pollution Prevention and Erosion and Sedimentation Control Plan must include the following information:

- Narrative;
 - Construction Period Operation and Maintenance Plan;
 - Names of Persons or Entity Responsible for Plan Compliance;
 - Construction Period Pollution Prevention Measures;
 - Erosion and Sedimentation Control Plan Drawings;
 - Detail drawings and specifications for erosion control BMPs, including sizing calculations;
 - Vegetation Planning;
 - Site Development Plan;
 - Construction Sequencing Plan;
 - Sequencing of Erosion and Sedimentation Controls;
 - Operation and Maintenance of Erosion and Sedimentation Controls;
 - Inspection Schedule;
 - Maintenance Schedule;
 - Inspection and Maintenance Log Form.
- A Construction Period Pollution Prevention and Erosion and Sedimentation Control Plan containing the information set forth above has been included in the Stormwater Report.



Checklist for Stormwater Report

Checklist (continued)

Standard 8: Construction Period Pollution Prevention and Erosion and Sedimentation Control (continued)

- The project is highly complex and information is included in the Stormwater Report that explains why it is not possible to submit the Construction Period Pollution Prevention and Erosion and Sedimentation Control Plan with the application. A Construction Period Pollution Prevention and Erosion and Sedimentation Control has **not** been included in the Stormwater Report but will be submitted **before** land disturbance begins.
- The project is **not** covered by a NPDES Construction General Permit.
- The project is covered by a NPDES Construction General Permit and a copy of the SWPPP is in the Stormwater Report.
- The project is covered by a NPDES Construction General Permit but no SWPPP been submitted. The SWPPP will be submitted BEFORE land disturbance begins.

Standard 9: Operation and Maintenance Plan

- The Post Construction Operation and Maintenance Plan is included in the Stormwater Report and includes the following information:
 - Name of the stormwater management system owners;
 - Party responsible for operation and maintenance;
 - Schedule for implementation of routine and non-routine maintenance tasks;
 - Plan showing the location of all stormwater BMPs maintenance access areas;
 - Description and delineation of public safety features;
 - Estimated operation and maintenance budget; and
 - Operation and Maintenance Log Form.
- The responsible party is **not** the owner of the parcel where the BMP is located and the Stormwater Report includes the following submissions:
 - A copy of the legal instrument (deed, homeowner's association, utility trust or other legal entity) that establishes the terms of and legal responsibility for the operation and maintenance of the project site stormwater BMPs;
 - A plan and easement deed that allows site access for the legal entity to operate and maintain BMP functions.

Standard 10: Prohibition of Illicit Discharges

- The Long-Term Pollution Prevention Plan includes measures to prevent illicit discharges;
- An Illicit Discharge Compliance Statement is attached;
- NO Illicit Discharge Compliance Statement is attached but will be submitted **prior to** the discharge of any stormwater to post-construction BMPs.

Appendix B – HydroCAD Hydrological Computations

Existing Conditions

Routing Diagram

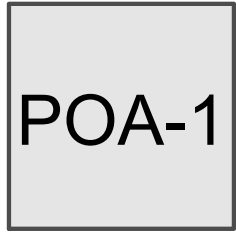

Southern Abutter

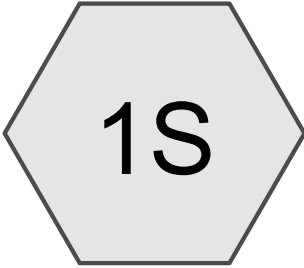

Site to Abutter

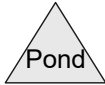
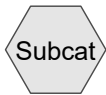

2-Year, 24 Hour Design Storm

20155_Existing Conditions

Prepared by RJ O'Connell & Associates, Inc.

HydroCAD® 10.00-25 s/n 04881 © 2019 HydroCAD Software Solutions LLC

839 Saratoga St, Boston, Ma

Type III 24-hr 2-Year Rainfall=3.20"

Printed 2/16/2021

Page 2

Time span=0.00-48.00 hrs, dt=0.05 hrs, 961 points
Runoff by SCS TR-20 method, UH=SCS, Weighted-CN
Reach routing by Stor-Ind+Trans method - Pond routing by Stor-Ind method

Subcatchment 1S: Site to Abutter

Runoff Area=5,000 sf 82.40% Impervious Runoff Depth=2.75"
Tc=6.0 min CN=96 Runoff=0.3 cfs 1,145 cf

Reach POA-1: Southern Abutter

Inflow=0.3 cfs 1,145 cf
Outflow=0.3 cfs 1,145 cf

Total Runoff Area = 5,000 sf Runoff Volume = 1,145 cf Average Runoff Depth = 2.75"
17.60% Pervious = 880 sf 82.40% Impervious = 4,120 sf

20155_Existing Conditions

Prepared by RJ O'Connell & Associates, Inc.

HydroCAD® 10.00-25 s/n 04881 © 2019 HydroCAD Software Solutions LLC

839 Saratoga St, Boston, Ma
Type III 24-hr 2-Year Rainfall=3.20"

Printed 2/16/2021

Page 3

Summary for Subcatchment 1S: Site to Abutter

Runoff = 0.3 cfs @ 12.09 hrs, Volume= 1,145 cf, Depth= 2.75"

Runoff by SCS TR-20 method, UH=SCS, Weighted-CN, Time Span= 0.00-48.00 hrs, dt= 0.05 hrs
Type III 24-hr 2-Year Rainfall=3.20"

Area (sf)	CN	Description
1,189	98	Roofs, HSG D
880	84	50-75% Grass cover, Fair, HSG D
2,931	98	Unconnected pavement, HSG D
5,000	96	Weighted Average
880		17.60% Pervious Area
4,120		82.40% Impervious Area
2,931		71.14% Unconnected

Tc (min)	Length (feet)	Slope (ft/ft)	Velocity (ft/sec)	Capacity (cfs)	Description
6.0					Direct Entry,

Summary for Reach POA-1: Southern Abutter

Inflow Area = 5,000 sf, 82.40% Impervious, Inflow Depth = 2.75" for 2-Year event

Inflow = 0.3 cfs @ 12.09 hrs, Volume= 1,145 cf

Outflow = 0.3 cfs @ 12.09 hrs, Volume= 1,145 cf, Atten= 0%, Lag= 0.0 min

Routing by Stor-Ind+Trans method, Time Span= 0.00-48.00 hrs, dt= 0.05 hrs

10-Year, 24 Hour Design Storm

20155_Existing Conditions

Prepared by RJ O'Connell & Associates, Inc.
HydroCAD® 10.00-25 s/n 04881 © 2019 HydroCAD Software Solutions LLC

839 Saratoga St, Boston, Ma
Type III 24-hr 10-Year Rainfall=4.60"
Printed 2/16/2021
Page 4

Time span=0.00-48.00 hrs, dt=0.05 hrs, 961 points
Runoff by SCS TR-20 method, UH=SCS, Weighted-CN
Reach routing by Stor-Ind+Trans method - Pond routing by Stor-Ind method

Subcatchment 1S: Site to Abutter

Runoff Area=5,000 sf 82.40% Impervious Runoff Depth=4.14"
Tc=6.0 min CN=96 Runoff=0.5 cfs 1,723 cf

Reach POA-1: Southern Abutter

Inflow=0.5 cfs 1,723 cf
Outflow=0.5 cfs 1,723 cf

Total Runoff Area = 5,000 sf Runoff Volume = 1,723 cf Average Runoff Depth = 4.14"
17.60% Pervious = 880 sf 82.40% Impervious = 4,120 sf

20155_Existing Conditions

Prepared by RJ O'Connell & Associates, Inc.

HydroCAD® 10.00-25 s/n 04881 © 2019 HydroCAD Software Solutions LLC

839 Saratoga St, Boston, Ma

Type III 24-hr 10-Year Rainfall=4.60"

Printed 2/16/2021

Page 5

Summary for Subcatchment 1S: Site to Abutter

Runoff = 0.5 cfs @ 12.09 hrs, Volume= 1,723 cf, Depth= 4.14"

Runoff by SCS TR-20 method, UH=SCS, Weighted-CN, Time Span= 0.00-48.00 hrs, dt= 0.05 hrs
Type III 24-hr 10-Year Rainfall=4.60"

Area (sf)	CN	Description
1,189	98	Roofs, HSG D
880	84	50-75% Grass cover, Fair, HSG D
2,931	98	Unconnected pavement, HSG D
5,000	96	Weighted Average
880		17.60% Pervious Area
4,120		82.40% Impervious Area
2,931		71.14% Unconnected

Tc (min)	Length (feet)	Slope (ft/ft)	Velocity (ft/sec)	Capacity (cfs)	Description
6.0					Direct Entry,

Summary for Reach POA-1: Southern Abutter

Inflow Area = 5,000 sf, 82.40% Impervious, Inflow Depth = 4.14" for 10-Year event

Inflow = 0.5 cfs @ 12.09 hrs, Volume= 1,723 cf

Outflow = 0.5 cfs @ 12.09 hrs, Volume= 1,723 cf, Atten= 0%, Lag= 0.0 min

Routing by Stor-Ind+Trans method, Time Span= 0.00-48.00 hrs, dt= 0.05 hrs

25-Year, 24 Hour Design Storm

20155_Existing Conditions

Prepared by RJ O'Connell & Associates, Inc.
HydroCAD® 10.00-25 s/n 04881 © 2019 HydroCAD Software Solutions LLC

839 Saratoga St, Boston, Ma
Type III 24-hr 25-Year Rainfall=5.50"
Printed 2/16/2021
Page 6

Time span=0.00-48.00 hrs, dt=0.05 hrs, 961 points
Runoff by SCS TR-20 method, UH=SCS, Weighted-CN
Reach routing by Stor-Ind+Trans method - Pond routing by Stor-Ind method

Subcatchment 1S: Site to Abutter

Runoff Area=5,000 sf 82.40% Impervious Runoff Depth=5.03"
Tc=6.0 min CN=96 Runoff=0.6 cfs 2,096 cf

Reach POA-1: Southern Abutter

Inflow=0.6 cfs 2,096 cf
Outflow=0.6 cfs 2,096 cf

Total Runoff Area = 5,000 sf Runoff Volume = 2,096 cf Average Runoff Depth = 5.03"
17.60% Pervious = 880 sf 82.40% Impervious = 4,120 sf

20155_Existing Conditions

Prepared by RJ O'Connell & Associates, Inc.

HydroCAD® 10.00-25 s/n 04881 © 2019 HydroCAD Software Solutions LLC

839 Saratoga St, Boston, Ma

Type III 24-hr 25-Year Rainfall=5.50"

Printed 2/16/2021

Page 7

Summary for Subcatchment 1S: Site to Abutter

Runoff = 0.6 cfs @ 12.09 hrs, Volume= 2,096 cf, Depth= 5.03"

Runoff by SCS TR-20 method, UH=SCS, Weighted-CN, Time Span= 0.00-48.00 hrs, dt= 0.05 hrs
Type III 24-hr 25-Year Rainfall=5.50"

Area (sf)	CN	Description
1,189	98	Roofs, HSG D
880	84	50-75% Grass cover, Fair, HSG D
2,931	98	Unconnected pavement, HSG D
5,000	96	Weighted Average
880		17.60% Pervious Area
4,120		82.40% Impervious Area
2,931		71.14% Unconnected

Tc (min)	Length (feet)	Slope (ft/ft)	Velocity (ft/sec)	Capacity (cfs)	Description
6.0					Direct Entry,

Summary for Reach POA-1: Southern Abutter

Inflow Area = 5,000 sf, 82.40% Impervious, Inflow Depth = 5.03" for 25-Year event

Inflow = 0.6 cfs @ 12.09 hrs, Volume= 2,096 cf

Outflow = 0.6 cfs @ 12.09 hrs, Volume= 2,096 cf, Atten= 0%, Lag= 0.0 min

Routing by Stor-Ind+Trans method, Time Span= 0.00-48.00 hrs, dt= 0.05 hrs

100-Year, 24 Hour Design Storm

20155_Existing Conditions

Prepared by RJ O'Connell & Associates, Inc.

HydroCAD® 10.00-25 s/n 04881 © 2019 HydroCAD Software Solutions LLC

839 Saratoga St, Boston, Ma

Type III 24-hr 100-Year Rainfall=6.60"

Printed 2/16/2021

Page 8

Time span=0.00-48.00 hrs, dt=0.05 hrs, 961 points
Runoff by SCS TR-20 method, UH=SCS, Weighted-CN
Reach routing by Stor-Ind+Trans method - Pond routing by Stor-Ind method

Subcatchment 1S: Site to Abutter

Runoff Area=5,000 sf 82.40% Impervious Runoff Depth=6.13"
Tc=6.0 min CN=96 Runoff=0.7 cfs 2,552 cf

Reach POA-1: Southern Abutter

Inflow=0.7 cfs 2,552 cf
Outflow=0.7 cfs 2,552 cf

Total Runoff Area = 5,000 sf Runoff Volume = 2,552 cf Average Runoff Depth = 6.13"
17.60% Pervious = 880 sf 82.40% Impervious = 4,120 sf

20155_Existing Conditions

Prepared by RJ O'Connell & Associates, Inc.

HydroCAD® 10.00-25 s/n 04881 © 2019 HydroCAD Software Solutions LLC

839 Saratoga St, Boston, Ma

Type III 24-hr 100-Year Rainfall=6.60"

Printed 2/16/2021

Page 9

Summary for Subcatchment 1S: Site to Abutter

Runoff = 0.7 cfs @ 12.09 hrs, Volume= 2,552 cf, Depth= 6.13"

Runoff by SCS TR-20 method, UH=SCS, Weighted-CN, Time Span= 0.00-48.00 hrs, dt= 0.05 hrs
Type III 24-hr 100-Year Rainfall=6.60"

Area (sf)	CN	Description
1,189	98	Roofs, HSG D
880	84	50-75% Grass cover, Fair, HSG D
2,931	98	Unconnected pavement, HSG D
5,000	96	Weighted Average
880		17.60% Pervious Area
4,120		82.40% Impervious Area
2,931		71.14% Unconnected

Tc (min)	Length (feet)	Slope (ft/ft)	Velocity (ft/sec)	Capacity (cfs)	Description
6.0					Direct Entry,

Summary for Reach POA-1: Southern Abutter

Inflow Area = 5,000 sf, 82.40% Impervious, Inflow Depth = 6.13" for 100-Year event

Inflow = 0.7 cfs @ 12.09 hrs, Volume= 2,552 cf

Outflow = 0.7 cfs @ 12.09 hrs, Volume= 2,552 cf, Atten= 0%, Lag= 0.0 min

Routing by Stor-Ind+Trans method, Time Span= 0.00-48.00 hrs, dt= 0.05 hrs

Proposed Conditions

Routing Diagram



Southern Abutter

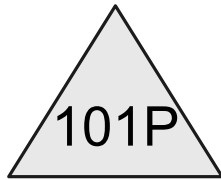

Infiltration System

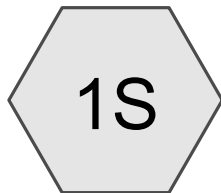

Site to Abutter

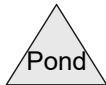
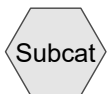

2-Year, 24-Hour Design Storm

20155_Proposed Conditions

Prepared by RJ O'Connell & Associates, Inc.

HydroCAD® 10.00-25 s/n 04881 © 2019 HydroCAD Software Solutions LLC

839 Saratoga St, Boston, Ma
Type III 24-hr 2-Year Rainfall=3.20"

Printed 2/16/2021

Page 2

Time span=0.00-48.00 hrs, dt=0.05 hrs, 961 points
Runoff by SCS TR-20 method, UH=SCS, Weighted-CN
Reach routing by Stor-Ind+Trans method - Pond routing by Stor-Ind method

Subcatchment 1S: Site to Abutter

Runoff Area=5,000 sf 95.96% Impervious Runoff Depth=2.86"
Tc=6.0 min CN=97 Runoff=0.3 cfs 1,190 cf

Reach POA-1: Southern Abutter

Inflow=0.3 cfs 611 cf
Outflow=0.3 cfs 611 cf

Pond 101P: Infiltration System

Peak Elev=11.94' Storage=409 cf Inflow=0.3 cfs 1,190 cf
Discarded=0.0 cfs 397 cf Primary=0.3 cfs 611 cf Outflow=0.3 cfs 1,008 cf

Total Runoff Area = 5,000 sf Runoff Volume = 1,190 cf Average Runoff Depth = 2.86"
4.04% Pervious = 202 sf 95.96% Impervious = 4,798 sf

20155_Proposed Conditions

Prepared by RJ O'Connell & Associates, Inc.

Printed 2/16/2021

HydroCAD® 10.00-25 s/n 04881 © 2019 HydroCAD Software Solutions LLC

Page 3

Summary for Subcatchment 1S: Site to Abutter

Runoff = 0.3 cfs @ 12.09 hrs, Volume= 1,190 cf, Depth= 2.86"

Runoff by SCS TR-20 method, UH=SCS, Weighted-CN, Time Span= 0.00-48.00 hrs, dt= 0.05 hrs
Type III 24-hr 2-Year Rainfall=3.20"

Area (sf)	CN	Description
3,282	98	Roofs, HSG D
202	80	>75% Grass cover, Good, HSG D
* 1,516	98	Unconnected roofs, (Pavement/ Walls) HSG D
5,000	97	Weighted Average
202		4.04% Pervious Area
4,798		95.96% Impervious Area
1,516		31.60% Unconnected

Tc (min)	Length (feet)	Slope (ft/ft)	Velocity (ft/sec)	Capacity (cfs)	Description
6.0					Direct Entry, Minimum Engineering Standard

Summary for Reach POA-1: Southern Abutter

Inflow Area = 5,000 sf, 95.96% Impervious, Inflow Depth = 1.47" for 2-Year event
 Inflow = 0.3 cfs @ 12.09 hrs, Volume= 611 cf
 Outflow = 0.3 cfs @ 12.09 hrs, Volume= 611 cf, Atten= 0%, Lag= 0.0 min

Routing by Stor-Ind+Trans method, Time Span= 0.00-48.00 hrs, dt= 0.05 hrs

Summary for Pond 101P: Infiltration System

Inflow Area = 5,000 sf, 95.96% Impervious, Inflow Depth = 2.86" for 2-Year event
 Inflow = 0.3 cfs @ 12.09 hrs, Volume= 1,190 cf
 Outflow = 0.3 cfs @ 12.09 hrs, Volume= 1,008 cf, Atten= 0%, Lag= 0.3 min
 Discarded = 0.0 cfs @ 12.09 hrs, Volume= 397 cf
 Primary = 0.3 cfs @ 12.09 hrs, Volume= 611 cf

Routing by Stor-Ind method, Time Span= 0.00-48.00 hrs, dt= 0.05 hrs
 Peak Elev= 11.94' @ 12.09 hrs Surf.Area= 200 sf Storage= 409 cf

Plug-Flow detention time= 406.7 min calculated for 1,007 cf (85% of inflow)
 Center-of-Mass det. time= 343.4 min (1,109.5 - 766.0)

Volume	Invert	Avail.Storage	Storage Description
#1	7.80'	186 cf	Scituate 4'x4' Leaching Galley x 4 Inside #2 Inside= 42.2"W x 45.0"H => 13.3 sf x 3.50'L = 46.4 cf Outside= 54.0"W x 51.0"H => 15.6 sf x 4.00'L = 62.3 cf
#2	7.00'	255 cf	10.00'W x 20.00'L x 5.50'H Excavation 1,100 cf Overall - 249 cf Embedded = 851 cf x 30.0% Voids
		441 cf	Total Available Storage

20155_Proposed Conditions

Prepared by RJ O'Connell & Associates, Inc.

HydroCAD® 10.00-25 s/n 04881 © 2019 HydroCAD Software Solutions LLC

Device	Routing	Invert	Outlet Devices
#1	Discarded	7.00'	0.270 in/hr Exfiltration over Wetted area
#2	Primary	11.70'	4.0" Vert. Orifice/Grate X 3.00 C= 0.600

Discarded OutFlow Max=0.0 cfs @ 12.09 hrs HW=11.94' (Free Discharge)
↳ **1=Exfiltration** (Exfiltration Controls 0.0 cfs)

Primary OutFlow Max=0.3 cfs @ 12.09 hrs HW=11.94' (Free Discharge)
↳ **2=Orifice/Grate** (Orifice Controls 0.3 cfs @ 1.66 fps)

10-Year, 24-Hour Design Storm

20155_Proposed Conditions

Prepared by RJ O'Connell & Associates, Inc.

HydroCAD® 10.00-25 s/n 04881 © 2019 HydroCAD Software Solutions LLC

839 Saratoga St, Boston, Ma

Type III 24-hr 10-Year Rainfall=4.60"

Printed 2/16/2021

Page 5

Time span=0.00-48.00 hrs, dt=0.05 hrs, 961 points
Runoff by SCS TR-20 method, UH=SCS, Weighted-CN
Reach routing by Stor-Ind+Trans method - Pond routing by Stor-Ind method

Subcatchment 1S: Site to Abutter

Runoff Area=5,000 sf 95.96% Impervious Runoff Depth=4.25"
Tc=6.0 min CN=97 Runoff=0.5 cfs 1,770 cf

Reach POA-1: Southern Abutter

Inflow=0.5 cfs 1,179 cf
Outflow=0.5 cfs 1,179 cf

Pond 101P: Infiltration System

Peak Elev=12.02' Storage=412 cf Inflow=0.5 cfs 1,770 cf
Discarded=0.0 cfs 409 cf Primary=0.5 cfs 1,179 cf Outflow=0.5 cfs 1,588 cf

Total Runoff Area = 5,000 sf Runoff Volume = 1,770 cf Average Runoff Depth = 4.25"
4.04% Pervious = 202 sf 95.96% Impervious = 4,798 sf

20155_Proposed Conditions

Prepared by RJ O'Connell & Associates, Inc.

HydroCAD® 10.00-25 s/n 04881 © 2019 HydroCAD Software Solutions LLC

839 Saratoga St, Boston, Ma
Type III 24-hr 10-Year Rainfall=4.60"

Printed 2/16/2021

Page 6

Summary for Subcatchment 1S: Site to Abutter

Runoff = 0.5 cfs @ 12.09 hrs, Volume= 1,770 cf, Depth= 4.25"

Runoff by SCS TR-20 method, UH=SCS, Weighted-CN, Time Span= 0.00-48.00 hrs, dt= 0.05 hrs
Type III 24-hr 10-Year Rainfall=4.60"

Area (sf)	CN	Description
3,282	98	Roofs, HSG D
202	80	>75% Grass cover, Good, HSG D
* 1,516	98	Unconnected roofs, (Pavement/ Walls) HSG D
5,000	97	Weighted Average
202		4.04% Pervious Area
4,798		95.96% Impervious Area
1,516		31.60% Unconnected

Tc (min)	Length (feet)	Slope (ft/ft)	Velocity (ft/sec)	Capacity (cfs)	Description
6.0					Direct Entry, Minimum Engineering Standard

Summary for Reach POA-1: Southern Abutter

Inflow Area = 5,000 sf, 95.96% Impervious, Inflow Depth = 2.83" for 10-Year event
Inflow = 0.5 cfs @ 12.09 hrs, Volume= 1,179 cf
Outflow = 0.5 cfs @ 12.09 hrs, Volume= 1,179 cf, Atten= 0%, Lag= 0.0 min

Routing by Stor-Ind+Trans method, Time Span= 0.00-48.00 hrs, dt= 0.05 hrs

Summary for Pond 101P: Infiltration System

Inflow Area = 5,000 sf, 95.96% Impervious, Inflow Depth = 4.25" for 10-Year event
Inflow = 0.5 cfs @ 12.09 hrs, Volume= 1,770 cf
Outflow = 0.5 cfs @ 12.09 hrs, Volume= 1,588 cf, Atten= 0%, Lag= 0.4 min
Discarded = 0.0 cfs @ 12.09 hrs, Volume= 409 cf
Primary = 0.5 cfs @ 12.09 hrs, Volume= 1,179 cf

Routing by Stor-Ind method, Time Span= 0.00-48.00 hrs, dt= 0.05 hrs
Peak Elev= 12.02' @ 12.09 hrs Surf.Area= 200 sf Storage= 412 cf

Plug-Flow detention time= 285.0 min calculated for 1,588 cf (90% of inflow)
Center-of-Mass det. time= 234.4 min (992.0 - 757.5)

Volume	Invert	Avail.Storage	Storage Description
#1	7.80'	186 cf	Scituate 4'x4' Leaching Galley x 4 Inside #2 Inside= 42.2"W x 45.0"H => 13.3 sf x 3.50'L = 46.4 cf Outside= 54.0"W x 51.0"H => 15.6 sf x 4.00'L = 62.3 cf
#2	7.00'	255 cf	10.00'W x 20.00'L x 5.50'H Excavation 1,100 cf Overall - 249 cf Embedded = 851 cf x 30.0% Voids
		441 cf	Total Available Storage

20155_Proposed Conditions

Prepared by RJ O'Connell & Associates, Inc.

HydroCAD® 10.00-25 s/n 04881 © 2019 HydroCAD Software Solutions LLC

839 Saratoga St, Boston, Ma

Type III 24-hr 10-Year Rainfall=4.60"

Printed 2/16/2021

Page 7

Device	Routing	Invert	Outlet Devices
#1	Discarded	7.00'	0.270 in/hr Exfiltration over Wetted area
#2	Primary	11.70'	4.0" Vert. Orifice/Grate X 3.00 C= 0.600

Discarded OutFlow Max=0.0 cfs @ 12.09 hrs HW=12.02' (Free Discharge)
↳ **1=Exfiltration** (Exfiltration Controls 0.0 cfs)

Primary OutFlow Max=0.5 cfs @ 12.09 hrs HW=12.02' (Free Discharge)
↳ **2=Orifice/Grate** (Orifice Controls 0.5 cfs @ 1.92 fps)

25-Year, 24-Hour Design Storm

20155_Proposed Conditions

Prepared by RJ O'Connell & Associates, Inc.

HydroCAD® 10.00-25 s/n 04881 © 2019 HydroCAD Software Solutions LLC

839 Saratoga St, Boston, Ma

Type III 24-hr 25-Year Rainfall=5.50"

Printed 2/16/2021

Page 8

Time span=0.00-48.00 hrs, dt=0.05 hrs, 961 points
Runoff by SCS TR-20 method, UH=SCS, Weighted-CN
Reach routing by Stor-Ind+Trans method - Pond routing by Stor-Ind method

Subcatchment 1S: Site to Abutter

Runoff Area=5,000 sf 95.96% Impervious Runoff Depth=5.15"
Tc=6.0 min CN=97 Runoff=0.6 cfs 2,144 cf

Reach POA-1: Southern Abutter

Inflow=0.6 cfs 1,546 cf
Outflow=0.6 cfs 1,546 cf

Pond 101P: Infiltration System

Peak Elev=12.09' Storage=416 cf Inflow=0.6 cfs 2,144 cf
Discarded=0.0 cfs 415 cf Primary=0.6 cfs 1,546 cf Outflow=0.6 cfs 1,961 cf

Total Runoff Area = 5,000 sf Runoff Volume = 2,144 cf Average Runoff Depth = 5.15"
4.04% Pervious = 202 sf 95.96% Impervious = 4,798 sf

20155_Proposed Conditions

Prepared by RJ O'Connell & Associates, Inc.

HydroCAD® 10.00-25 s/n 04881 © 2019 HydroCAD Software Solutions LLC

839 Saratoga St, Boston, Ma
Type III 24-hr 25-Year Rainfall=5.50"

Printed 2/16/2021

Page 9

Summary for Subcatchment 1S: Site to Abutter

Runoff = 0.6 cfs @ 12.09 hrs, Volume= 2,144 cf, Depth= 5.15"

Runoff by SCS TR-20 method, UH=SCS, Weighted-CN, Time Span= 0.00-48.00 hrs, dt= 0.05 hrs
Type III 24-hr 25-Year Rainfall=5.50"

Area (sf)	CN	Description
3,282	98	Roofs, HSG D
202	80	>75% Grass cover, Good, HSG D
* 1,516	98	Unconnected roofs, (Pavement/ Walls) HSG D
5,000	97	Weighted Average
202		4.04% Pervious Area
4,798		95.96% Impervious Area
1,516		31.60% Unconnected

Tc (min)	Length (feet)	Slope (ft/ft)	Velocity (ft/sec)	Capacity (cfs)	Description
6.0					Direct Entry, Minimum Engineering Standard

Summary for Reach POA-1: Southern Abutter

Inflow Area = 5,000 sf, 95.96% Impervious, Inflow Depth = 3.71" for 25-Year event
Inflow = 0.6 cfs @ 12.10 hrs, Volume= 1,546 cf
Outflow = 0.6 cfs @ 12.10 hrs, Volume= 1,546 cf, Atten= 0%, Lag= 0.0 min

Routing by Stor-Ind+Trans method, Time Span= 0.00-48.00 hrs, dt= 0.05 hrs

Summary for Pond 101P: Infiltration System

Inflow Area = 5,000 sf, 95.96% Impervious, Inflow Depth = 5.15" for 25-Year event
Inflow = 0.6 cfs @ 12.09 hrs, Volume= 2,144 cf
Outflow = 0.6 cfs @ 12.10 hrs, Volume= 1,961 cf, Atten= 1%, Lag= 0.5 min
Discarded = 0.0 cfs @ 12.10 hrs, Volume= 415 cf
Primary = 0.6 cfs @ 12.10 hrs, Volume= 1,546 cf

Routing by Stor-Ind method, Time Span= 0.00-48.00 hrs, dt= 0.05 hrs
Peak Elev= 12.09' @ 12.10 hrs Surf.Area= 200 sf Storage= 416 cf

Plug-Flow detention time= 242.3 min calculated for 1,961 cf (91% of inflow)
Center-of-Mass det. time= 198.0 min (951.8 - 753.8)

Volume	Invert	Avail.Storage	Storage Description
#1	7.80'	186 cf	Scituate 4'x4' Leaching Galley x 4 Inside #2 Inside= 42.2"W x 45.0"H => 13.3 sf x 3.50'L = 46.4 cf Outside= 54.0"W x 51.0"H => 15.6 sf x 4.00'L = 62.3 cf
#2	7.00'	255 cf	10.00'W x 20.00'L x 5.50'H Excavation 1,100 cf Overall - 249 cf Embedded = 851 cf x 30.0% Voids
		441 cf	Total Available Storage

20155_Proposed Conditions

Prepared by RJ O'Connell & Associates, Inc.

Printed 2/16/2021

HydroCAD® 10.00-25 s/n 04881 © 2019 HydroCAD Software Solutions LLC

Page 10

Device	Routing	Invert	Outlet Devices
#1	Discarded	7.00'	0.270 in/hr Exfiltration over Wetted area
#2	Primary	11.70'	4.0" Vert. Orifice/Grate X 3.00 C= 0.600

Discarded OutFlow Max=0.0 cfs @ 12.10 hrs HW=12.08' (Free Discharge)
 ↳ **1=Exfiltration** (Exfiltration Controls 0.0 cfs)

Primary OutFlow Max=0.6 cfs @ 12.10 hrs HW=12.08' (Free Discharge)
 ↳ **2=Orifice/Grate** (Orifice Controls 0.6 cfs @ 2.23 fps)

100-Year, 24-Hour Design Storm

20155_Proposed Conditions

Prepared by RJ O'Connell & Associates, Inc.

HydroCAD® 10.00-25 s/n 04881 © 2019 HydroCAD Software Solutions LLC

839 Saratoga St, Boston, Ma

Type III 24-hr 100-Year Rainfall=6.60"

Printed 2/16/2021

Page 11

Time span=0.00-48.00 hrs, dt=0.05 hrs, 961 points
Runoff by SCS TR-20 method, UH=SCS, Weighted-CN
Reach routing by Stor-Ind+Trans method - Pond routing by Stor-Ind method

Subcatchment 1S: Site to Abutter

Runoff Area=5,000 sf 95.96% Impervious Runoff Depth=6.24"
Tc=6.0 min CN=97 Runoff=0.7 cfs 2,601 cf

Reach POA-1: Southern Abutter

Inflow=0.7 cfs 1,997 cf
Outflow=0.7 cfs 1,997 cf

Pond 101P: Infiltration System

Peak Elev=12.18' Storage=422 cf Inflow=0.7 cfs 2,601 cf
Discarded=0.0 cfs 422 cf Primary=0.7 cfs 1,997 cf Outflow=0.7 cfs 2,418 cf

Total Runoff Area = 5,000 sf Runoff Volume = 2,601 cf Average Runoff Depth = 6.24"
4.04% Pervious = 202 sf 95.96% Impervious = 4,798 sf

20155_Proposed Conditions

Prepared by RJ O'Connell & Associates, Inc.

Printed 2/16/2021

HydroCAD® 10.00-25 s/n 04881 © 2019 HydroCAD Software Solutions LLC

Page 12

Summary for Subcatchment 1S: Site to Abutter

Runoff = 0.7 cfs @ 12.09 hrs, Volume= 2,601 cf, Depth= 6.24"

Runoff by SCS TR-20 method, UH=SCS, Weighted-CN, Time Span= 0.00-48.00 hrs, dt= 0.05 hrs
Type III 24-hr 100-Year Rainfall=6.60"

Area (sf)	CN	Description
3,282	98	Roofs, HSG D
202	80	>75% Grass cover, Good, HSG D
* 1,516	98	Unconnected roofs, (Pavement/ Walls) HSG D
5,000	97	Weighted Average
202		4.04% Pervious Area
4,798		95.96% Impervious Area
1,516		31.60% Unconnected

Tc (min)	Length (feet)	Slope (ft/ft)	Velocity (ft/sec)	Capacity (cfs)	Description
6.0					Direct Entry, Minimum Engineering Standard

Summary for Reach POA-1: Southern Abutter

Inflow Area = 5,000 sf, 95.96% Impervious, Inflow Depth = 4.79" for 100-Year event
 Inflow = 0.7 cfs @ 12.10 hrs, Volume= 1,997 cf
 Outflow = 0.7 cfs @ 12.10 hrs, Volume= 1,997 cf, Atten= 0%, Lag= 0.0 min

Routing by Stor-Ind+Trans method, Time Span= 0.00-48.00 hrs, dt= 0.05 hrs

Summary for Pond 101P: Infiltration System

Inflow Area = 5,000 sf, 95.96% Impervious, Inflow Depth = 6.24" for 100-Year event
 Inflow = 0.7 cfs @ 12.09 hrs, Volume= 2,601 cf
 Outflow = 0.7 cfs @ 12.10 hrs, Volume= 2,418 cf, Atten= 1%, Lag= 0.8 min
 Discarded = 0.0 cfs @ 12.10 hrs, Volume= 422 cf
 Primary = 0.7 cfs @ 12.10 hrs, Volume= 1,997 cf

Routing by Stor-Ind method, Time Span= 0.00-48.00 hrs, dt= 0.05 hrs
 Peak Elev= 12.18' @ 12.10 hrs Surf.Area= 200 sf Storage= 422 cf

Plug-Flow detention time= 206.2 min calculated for 2,418 cf (93% of inflow)
 Center-of-Mass det. time= 167.7 min (918.1 - 750.4)

Volume	Invert	Avail.Storage	Storage Description
#1	7.80'	186 cf	Scituate 4'x4' Leaching Galley x 4 Inside #2 Inside= 42.2"W x 45.0"H => 13.3 sf x 3.50'L = 46.4 cf Outside= 54.0"W x 51.0"H => 15.6 sf x 4.00'L = 62.3 cf
#2	7.00'	255 cf	10.00'W x 20.00'L x 5.50'H Excavation 1,100 cf Overall - 249 cf Embedded = 851 cf x 30.0% Voids
		441 cf	Total Available Storage

20155_Proposed Conditions

Prepared by RJ O'Connell & Associates, Inc.

Printed 2/16/2021

HydroCAD® 10.00-25 s/n 04881 © 2019 HydroCAD Software Solutions LLC

Page 13

Device	Routing	Invert	Outlet Devices
#1	Discarded	7.00'	0.270 in/hr Exfiltration over Wetted area
#2	Primary	11.70'	4.0" Vert. Orifice/Grate X 3.00 C= 0.600

Discarded OutFlow Max=0.0 cfs @ 12.10 hrs HW=12.18' (Free Discharge)
 ↳ **1=Exfiltration** (Exfiltration Controls 0.0 cfs)

Primary OutFlow Max=0.7 cfs @ 12.10 hrs HW=12.18' (Free Discharge)
 ↳ **2=Orifice/Grate** (Orifice Controls 0.7 cfs @ 2.71 fps)

III. Operation and Maintenance Plan (O&M)



Operation and Maintenance Plan (O&M)

**839 Saratoga Street
Boston, MA 02128**

Prepared by:

**RJO'CONNELL & ASSOCIATES, INC.
80 Montvale Ave, Suite 201
Stoneham, MA 02180**

Date:

February 16, 2021

Revised:

NA

Table of Contents

1.0 Introduction..... 1
2.0 Stormwater Management System Operation and Maintenance (O&M) 2
3.0 Long Term Pollution Prevention Plan (LTPPP)..... 5
 3.1 Materials Covered..... 5
 3.2 Materials Management Practices 5
 3.3 Spill Prevention and Response Procedures..... 6
4.0 Snow Management..... 8

Appendix – Maintenance and Inspection Forms

- Activity Guide
- Comprehensive Annual Evaluation and Inspection Report
- Weekly Inspection Checklist
- Quarterly Inspection Checklist
- Biannual Inspection Checklist
- Annual Inspection Checklist
- Spill and Leak History

1.0 Introduction

This Operation and Maintenance Plan has been prepared to ensure that the stormwater management system implemented for 839 Saratoga Street, Boston, Massachusetts functions as designed. It has also been prepared to develop and carry out suitable practices for source control and pollution prevention. It consists of three sections:

Section 1 – Introduction

Section 2 – Stormwater Management System Operation and Maintenance (O&M)

Describes the various components of the stormwater management system, identifies the inspection and maintenance tasks to be undertaken after construction is complete, and includes a schedule for implementing these tasks to ensure the proper long-term operation of the system.

Section 3 – Long Term Pollution Prevention Plan (LTPPP)

Identifies and implements suitable measures, practices, and procedures for source control and pollution prevention.

2.0 Stormwater Management System Operation and Maintenance (O&M)

The objectives of the stormwater management system are to effectively control and treat stormwater runoff from the site in accordance with the City of Boston requirements for On-Site Drainage (Stormwater Management). To accomplish this objective, the following Best Management Practices (BMPs) are included in the stormwater management system:

Treatment BMP

- Subsurface infiltration system to reduce the potential for flooding.
- Catch Basin to reduce the potential for flooding and to provide water quality improvements.

In consideration of the foregoing, it is the ongoing responsibility of the Landowner and his/her successors and assignees to adequately maintain the on-site stormwater management/BMP facilities. Adequate maintenance is herein defined as good working condition so that these facilities are performing their design functions.

Based on this, the Landowner and his/her successors and assignees will be responsible for implementing the Operation and Maintenance Plan. Upon transfer of ownership of the property, the Landowner is required to notify the new owner of the presence of the stormwater management system and the requirements of this Operation and Maintenance Plan.

Property Information

Address: 839 Saratoga Street
Boston Ma, 02128

Responsibilities of Landowner: Coordinate all aspects of the Operation and Maintenance Plan, coordinate and hire any other Pollution Prevention Team members in order to conduct inspections, keep all records, and coordinate with contractors for maintenance and repairs of the stormwater management system.

Day to Day Operator/Site Contractor

Company Name: TBD
Contractor Contact: TBD
Phone: TBD

Spill Prevention & Control Contractor

Primary Contact: TBD
Company Name: TBD
Phone: TBD

Emergency Contact: TBD
Company Name: TBD
Phone: TBD

Consultant Contact: TBD
Company Name: TBD
Phone: TBD

Department of Environmental Protection (DEP) Contact

Spill Emergency Coordinator

Contact Name: TBDPhone: TBDMunicipal ContactContact Name: John Dempsey, Fire ChiefPhone: 617-343-3550Other Pollution Prevention Team Members

Member: Qualified Engineering and/or Environmental Consulting Firm(s)

Responsibilities: Conduct scheduled inspections, maintain records, advise the Landowner of maintenance needs, ensure inspection maintenance and repairs are completed, and keep and maintain all records and inspection reports. A copy of all reports shall be kept on the site at a designated location at all times.

Company Name: TBDAddress: TBDPhone: TBDTeam Member Training

The Landowner will coordinate an annual in-house training session with the qualified Engineering and/or Environmental Consulting Firm to discuss the Operation and Maintenance Plan, ongoing inspections, and maintenance and preventative maintenance procedures.

Annual training sessions will generally include the following:

- Discuss the Operation and Maintenance Plan
 - What it is – identify potential sources of stormwater pollution and methods of reducing or eliminating that pollution.
 - What it contains – emphasize good housekeeping measures and location of potential pollution sources.
 - Pollution Prevention Team – introduce the team and responsibilities, explain that the goal is to continually monitor the stormwater management system and encourage input and assistance from all.
- Review and explain the storm drainage system, how it works, and its components.
- Emphasize the importance of maintaining current and up-to-date inspection reports and maintenance records of BMPs. Documentation shall include any changes to the Operation and Maintenance Plan's procedures to accommodate changes and revisions to BMPs.

The components of the stormwater management system must be inspected, monitored, and maintained as explained below in order to ensure that the on-site stormwater management/BMP facilities are functioning as designed. Routine inspection and proper maintenance of these individual components is essential to providing the long-term enhancement of both the quality and quantity of runoff to the subsurface infiltration system.

Site Clean-Up:

Routine sweeping of paved areas is an effective method to provide important nonpoint source pollution control and will be performed regularly. Most stormwater pollutants travel with the suspended solids contained in the stormwater runoff, and regular sweeping will help reduce a portion of this load. Sweeping and site clean-up, especially during the period immediately following winter snowmelt (March/April), when sand and other debris has accumulated on the pavement, will capture a peak sediment load before spring rains wash that sand and debris into the stormwater management system, and/or off the site.

Inspection: Paved areas will be inspected for litter on a weekly basis, picked up, and properly disposed of immediately.

Maintenance: All paved areas will be picked up and swept clean of sand, litter, trash, etc. on a regular basis. Clean-up services will be conducted at least twice a year, once between October and December (after leaf fall), and once during the month of March or April (after snow melt). Additional cleanup services will be conducted as necessary.

Subsurface Infiltration System:

Subsurface infiltration systems are underground structures designed to temporarily store runoff and allow it to slowly infiltrate into the ground.

- (System 1A) This system consists of four (4) 4'x4' Precast Leaching Galleys surrounded by 1-1/2 to 2 inch angular, washed stone wrapped in filter fabric. To ensure proper functioning of these structures, they will be inspected and maintained as follows:

Inspection: Inlets and riser pipe are to be inspected biannually and after major storm events (3.8 inches or more in a 24-hour period).

Maintenance: Maintenance should be minimal since runoff is primarily from the roof of the building (roof runoff is considered clean). If there is a visible build-up of sediment (6 inches), it should be jet vacuumed by a licensed contractor and disposed of in accordance with applicable local, state, and federal guidelines and regulations.

Catch Basins:

Stormwater runoff from pavement areas is directed to catch basins or trench drains via site grading. Catch basins are equipped with a deep (4 foot) sump and a hood. The sumps are designed to capture sediment and coarse particles and the hoods prevent hydrocarbons and other floatable debris from entering the drainage system. To ensure proper functioning of catch basins and trench drains, each will be inspected and maintained as follows:

Inspection: Quarterly and after major storm events (2.0 inches or more in a 24 hour period). Structural damage and other malfunctions are to be noted and reported. Basins and trench drains shall also be inspected during every major rain event to ensure the grates are not clogged and are functioning properly.

Maintenance: To be cleaned 4 time a year by a licensed contractor. Sediment and hydrocarbons will be properly handled and legally disposed of off site in accordance with local, state, and federal guidelines and regulations. Any structural damage to catch basins and/or castings will be repaired upon discovery.

3.0 Long Term Pollution Prevention Plan (LTPPP)**3.1 Materials Covered**

The following materials or substances are expected to be present on-site after construction:

Cleaning solvents	Detergents
Paints	Solid waste
Pet waste	

3.2 Materials Management Practices

The following materials management practices will be used to reduce the risk of spills or other accidental exposure of materials and substances to stormwater runoff. The Landowner will be responsible for ensuring that these procedures are followed.

1. Good Housekeeping
 - a) An effort will be made to store only enough products required to do the job.
 - b) All materials stored on-site will be stored in a neat, orderly manner and under a roof or in a containment area if possible. At a minimum, all containers will be stored with their lids on when not in use. Drip pans shall be provided under all dispensers.
 - c) Products will be kept in their original containers with the original manufacturer's label in legible condition.
 - d) Substances will not be mixed with one another unless recommended by the manufacturer.
 - e) Whenever possible, all of a product will be used up before disposing of the container.
 - f) Manufacturer's recommendations for proper use and disposal will be followed.

- g) The Landowner will be responsible for regular inspections to ensure proper use and disposal of materials.

2. Hazardous Substances

Safety Data Sheets (SDSs) for each product with hazardous properties that is used at the site will be obtained and used for the proper management of potential wastes that may result from these products. An SDS will be posted in the immediate area where such a product is stored and/or used.

- a) SDSs will be procured and used for each product.
- b) If surplus product must be disposed of, the manufacturer's and local/state/federal required methods for proper disposal must be followed.

3. Cleaning Solvents, Detergents, and Paints

All containers will be tightly sealed and stored when not in use. Excess cleaning solvents, detergents, and points will not be discharged to the stormwater system but will be properly disposed of according to manufacturer's instructions and local/state/federal regulations.

4. Solid Waste

All waste materials will be collected and stored in an appropriately covered container and/or securely contained metal dumpster rented from a licensed local solid waste management company. The dumpster will comply with all local and state solid waste management regulations. The waste containers will be emptied a minimum of once per week, or more often if necessary. All waste containers will be located in an area where the likelihood of the containers contributing to stormwater discharges is negligible.

5. Pet Waste

The site will be inspected weekly for pet waste. Pet waste will be collected, placed in a closed, tied trash bag, and disposed of in accordance with applicable code requirements.

3.3 Spill Prevention and Response Procedures

It shall be the responsibility of the Landowner to be properly trained in spill prevention and the proper handling and cleanup procedures for hazardous substances and oil. No spilled hazardous substances or oil will be allowed to come in contact with stormwater discharges. If such contact occurs, the stormwater discharge will be contained on-site until appropriate measures in compliance with local, state, and federal regulations are taken to dispose of such contaminated stormwater.

- 1. In order to prevent or minimize the potential for a hazardous substances or oil spill to come into contact with stormwater, the following steps will be implemented:
 - a) All hazardous substances and oil will be stored in a secure location, with their lids on, preferably under cover, when not in use.
 - b) The minimum practical quantity of all such materials will be kept on-site.
 - c) A spill control and containment kit (containing, for example, absorbent materials, acid neutralizing powder, brooms, dust pans, mops, rags, gloves, goggles, plastic and metal trash containers, etc.) will be provided on-site.

- d) Manufacturer's recommended methods for spill cleanup will be clearly posted and the Landowner will be trained regarding these procedures and the location of the information and cleanup supplies.
 - e) It is the Landowner's responsibility to ensure that any hazardous substances on-site are disposed of properly by a licensed hazardous material disposal company. The Landowner is responsible for not exceeding hazardous substance storage requirements mandated by the EPA or state or local authority.
2. In the event of a spill of hazardous substances or oil, the following procedures must be followed:
- a) All measures must be taken to contain and abate the spill and to prevent the discharge of the hazardous substance or oil to stormwater or off-site. The spill area must be kept well ventilated and personnel must wear appropriate protective clothing to prevent injury from contact with the hazardous substances.
 - b) For spills of less than five (5) gallons of material, proceed with source control and containment, clean-up with absorbent materials, or other applicable means, unless an imminent hazard or other circumstance dictates that the spill should be treated by a professional emergency response contractor.
 - c) For spills greater than five (5) gallons of material, immediately contact the City Fire Chief, John Dempsey, at 617-343-3550, the MA DEP Hazardous Waste Incident Response Group at 617-792-7653, and an approved emergency response contractor. Provide information on the type of material spilled, the location of the spill, the quantity spilled, and the time of the spill to the emergency response contractor or coordinator. Then proceed with prevention, containment and/or clean-up if so desired.
 - d) If there is a Reportable Quantity (RQ) release, then the National Response Center will be notified immediately at 800-424-8802. Within 14 days a report will be submitted to the EPA regional office describing the release, the date and circumstances of the release, and the steps taken to prevent another release. This Pollution Prevention Plan must be updated to reflect any such steps or actions taken and measures to prevent the same from reoccurring.
3. The Landowner will be the spill prevention and response coordinator.

4.0 Snow Management

Snow management will be overseen by the Property Manager who will implement this plan and be authorized to utilize additional resources should unusual events occur. The Snow Management Contractor (SMC) shall be responsible for maintaining all roads, driveways, parking lots, sidewalks and pedestrian access areas for clear and safe travel. The SMC shall report directly to the Property Manager and maintain communication via cell phones 24 hours per day, 7 days per week. During extreme events, the first priority will be to clear and maintain proper access for employees and public safety vehicles. The next priority is parking areas, sidewalks, fire hydrants and delivery areas. Snow shall not be piled around light bases or fire hydrants and handicap parking areas shall be cleared frequently.

The anti-icing operations typically precede snow plowing and will be provided when conditions warrant. Within 12 months of concrete walks, pads, or other features being poured, no salt shall be placed on those surfaces. After the materials have cured for 12 months, a combination of calcium chloride deicers and sand (“washed”, fine to medium grade) shall be utilized. Parking areas shall receive spot treatment only when and where needed in a similar manner.

Snow plowing shall commence upon accumulation of two (2”) inches or more. Snow shall be deposited in appropriate snow storage areas outside of the 100-foot wetland buffer and in locations that will minimize the impact to pedestrian access, vehicle circulation, and parking spaces. During extreme events, excess snow will be removed offsite as necessary. The SMC shall keep existing catch basins open for drainage or water resulting from melting.

Once the storm is over, the SMC shall monitor all areas on-site for icy spots and snowdrifts. If necessary, an application of salt/sand mixture will be applied to all pavement areas so that the riding surface remains drivable. When the ambient temperature drops below 25 degrees Fahrenheit, all major areas shall receive an application of pre-wetted salt with calcium chloride to maintain melting action and ice-free surfaces for as long as possible. Salt loses its effectiveness as temperatures drop below 25 degrees Fahrenheit.

De-icing chemicals shall be kept in original containers with the original product label in legible condition. When not in use, de-icing materials shall be stored in a neat, orderly manner under cover with the container lids on.

STANDARD 10 - ILLICIT DISCHARGE STATEMENT

Certain types of discharges are allowable under the U.S. Environmental Protection Agency Construction General Permit, and it is the intent of this Operations and Maintenance Plan (O&M Plan) and Long Term Pollution Prevention Plan (LTPPP) to allow such discharges. These types of discharges will be allowed under the conditions that no pollutants will be allowed to come in contact with the water prior to, or after its discharge. The control measures which have been outlined previously in this O&M and LTPPP will be strictly followed to ensure that no contamination of these non-storm water discharges takes place. Illicit discharges, if they exist currently, shall be contained and eliminated in the manner specified by local, state and federal regulations, and will be prohibited in the proposed development.



Owner/Responsible Party

02-16-2021

Date

APPENDIX

Maintenance and Inspection Forms

**839 Saratoga Street
Operation and Maintenance Plan (O&M)
Activity Guide**

The table below indicates the minimum inspection and maintenance activities the Landowner needs to conduct for the Operation and Maintenance Plan. It also indicates who is responsible for each activity. The Activity Guide is provided to assist the Landowner and ensure that the activities are being conducted as scheduled.

Timing	Activity	Responsible Party
Weekly	Inspect lot/land Pet waste management	Landowner Landowner
Biannually	Inspect and clean subsurface infiltration systems, and Catch Basins	Landowner/Contractor
Annually	Comprehensive annual stormwater evaluation and inspection report	Landowner
March/April	Spring clean-up	Landowner/Contractor
Between October and December	Fall clean-up	Landowner/Contractor

839 Saratoga Street
Operation and Maintenance Plan (O&M)
Comprehensive Annual Evaluation and Inspection Report

Once a year, the Landowner must inspect and evaluate all aspects and provisions of the Operation and Maintenance Plan, complete the following report, and keep a copy on file at the site.

Inspector/Reviewers: _____

Date of Inspection/Review: _____

Note any changes to the Plan in the space below and in the appropriate section of the Plan.

1. Review the Pollution Prevention Team list and update as necessary.
Does the Pollution Prevention Team list need updating: (circle one) Yes No

2. Review the Operation and Maintenance Plan (O&M) and update as necessary.
Does the O&M need updating: (circle one) Yes No

3. Review the Inspection Checklists and the Spill and Leak History and update as necessary.
Do the Inspection Checklists or the Spill and Leak History need updating: (circle one) Yes No

4. Review the site drawings and update as necessary.
Do the site drawings need updating: (circle one) Yes No

Requested Changes (attach revisions)

839 Saratoga Street
Operation and Maintenance Plan (O&M)
Weekly Inspection Checklist

The following will be checked each week for sources of pollutants by the Landowner. If the condition in the “Action” column is observed, note the problem and corrective measures taken in the appropriate space. Make a new copy of this checklist each week.

Date: _____ **Checklist completed by:** _____

BMP/LOCATION	ACTION	DESCRIPTION OF PROBLEM	CORRECTIVE MEASURES TAKEN
Perimeter of property	Inspect for debris, trash, and pet waste		
Landscaped areas	Inspect for debris, trash, and pet waste		

839 Saratoga Street
Operation and Maintenance Plan (O&M)
Quarterly Inspection Checklist

The following will be checked each quarter for sources of pollutants by the Landowner. If the condition in the “Action” column is observed, note the problem and corrective measures taken in the appropriate space. Make a new copy of this checklist each quarter.

Date: _____ **Checklist completed by:** _____

BMP	ACTION	DESCRIPTION OF PROBLEM	CORRECTIVE MEASURES TAKEN
Catch Basins	Inspect for trash, excessive sediment in sump, grate (securely fastened and clear of debris)		

839 Saratoga Street
Operation and Maintenance Plan (O&M)
Biannual Inspection Checklist

The following will be checked biannually for sources of pollutants by the Landowner. If the condition in the “Action” column is observed, note the problem and corrective measures taken in the appropriate space. Make a new copy of this checklist biannually.

Date: _____ **Checklist completed by:** _____

BMP	ACTION	DESCRIPTION OF PROBLEM	CORRECTIVE MEASURES TAKEN
Subsurface infiltration systems	Inspect and clean or otherwise address clogged pipes, trash, oil sheen, excessive sediment, structural damage		
Catch Basins	Inspect for trash, excessive sediment in sump, grate (securely fastened and clear of debris)		

839 Saratoga Street
Operation and Maintenance Plan (O&M)
Annual Inspection Checklist

The following will be checked annually for sources of pollutants by the Landowner. If the condition in the “Action” column is observed, note the problem and corrective measures taken in the appropriate space. Make a new copy of this checklist annually.

Date: _____ **Checklist completed by:** _____

BMP	ACTION	DESCRIPTION OF PROBLEM	CORRECTIVE MEASURES TAKEN
Comprehensive annual stormwater evaluation and inspection report	Complete evaluation and prepare inspection report		

