



The Embrace & 1965 Freedom Rally Memorial Plaza

Boston Landmarks Commission
Design Approval Application
May 4, 2021

Call to Action

King Boston is a privately funded non-profit working closely with the City of Boston and the Boston Foundation to create a living memorial and programs honoring the legacy of Dr. Martin Luther King, Jr. and Coretta Scott King, and their time and work together in Boston.

The memorial is intended to inspire visitors to reflect on the values of racial and economic justice that both espoused. Through the memorial and related programming, King Boston envisions an inclusive and equitable Boston for all.



THE EMBRACE AND THE PROCESS

- 14 community meeting
- 126 submissions
- Proposal displayed at the Bolling Building and the BPL

A panel of experts – renowned educators, visual artists and curators rooted in the Black tradition organized by the City of Boston and King Boston, selected “**The Embrace**”

Hank Willis Thomas, a New York based, internationally acclaimed African American conceptual artist, and MASS Design Group in March 2019.



1965 Freedom Rally at Boston Common

“It would be irresponsible of me to deny the crippling poverty and injustice that exists in some sections of this community. The vision of the New Boston must extend into the heart of Roxbury. Boston must be a testing ground for the ideal of freedom.”

Martin Luther King, Jr. – Speech on Boston Common, '65

Why we march with Dr. Martin Luther King



We march today with Dr. Martin Luther King to protest the sufferings endured by the citizens of Boston.

WE MARCH TO CITY HALL

To protest the exclusion of the poor from anti-poverty planning.
To protest the bad faith of public officials in failing to enforce our housing codes.
To protest continued segregation in public housing.
In short, we march to protest the lie that a New Boston can be built without social justice.

WE MARCH TO THE SCHOOL COMMITTEE

To protest poor and racially imbalanced schools, and demand a commitment by the School Committee to a program and timetable to end this educational genocide, beginning September 1965.
To call on the citizens of Boston to repudiate the School Committee majority which says:

“These Negro parents have no background, they are just a pair of hands.”
“We do not have inferior schools; what we have been getting is an inferior type of child.”
“White parents don't want their children to go to school with backward Negroes.”

Will YOU Join Us?

FREEDOM RALLY

Pre-Rally Master of Ceremonies: Rev. Gilbert Caldwell
Welcome: Governor John A. Volpe
& Message of Welcome from Richard Cardinal Cushing
Master of Ceremonies: Rev. Virgil Wood
Speakers: Mr. Alan Gartner, Mrs. Ruth Batsen, Dr. Ralph Abernathy, Dr. Martin Luther King.
Benediction: Rev. Richard Owens



Mr. Alan Gartner
Chairman, Boston Congress of Racial Equality



Mrs. Ruth Batsen
Massachusetts Commission Against Discrimination



Rev. Virgil Wood
President, Massachusetts Unit, S.C.L.C.



Dr. Ralph Abernathy
Vice President at Large, Southern Christian Leadership Conference



Dr. Martin L. King
President, Southern Christian Leadership Conference.

Only program participants are seated on the platform. There is a reserved section for special guests.





Vicinity Plan

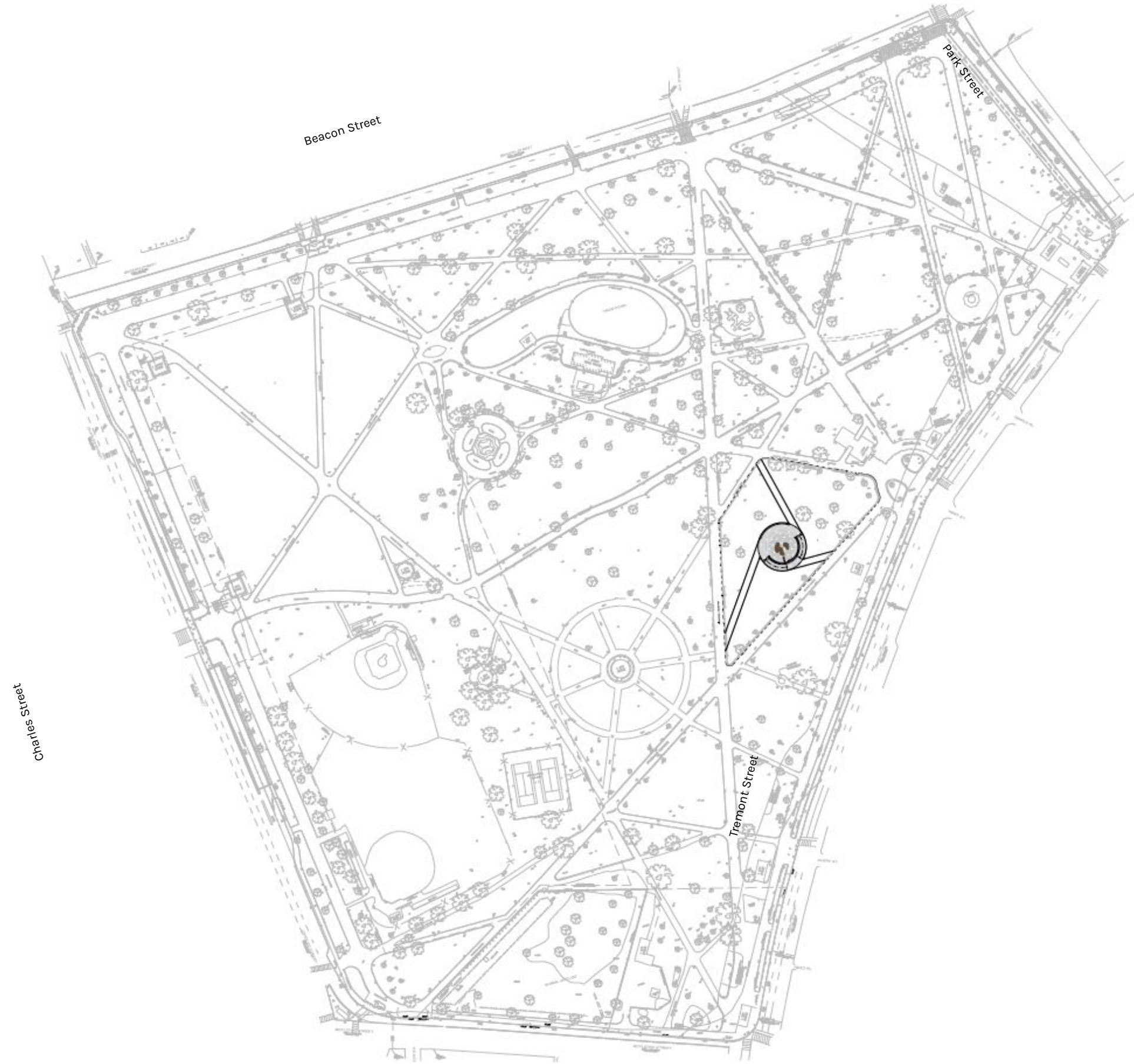

Existing Conditions

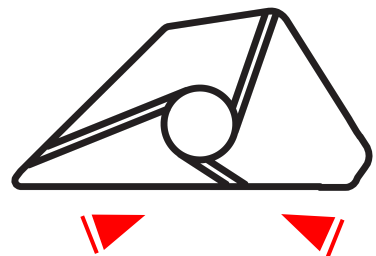
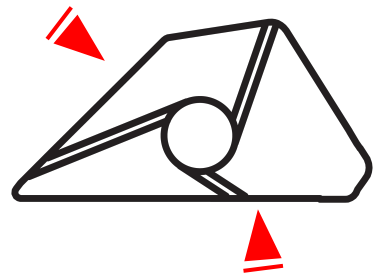

Existing Conditions

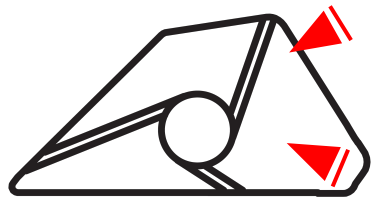

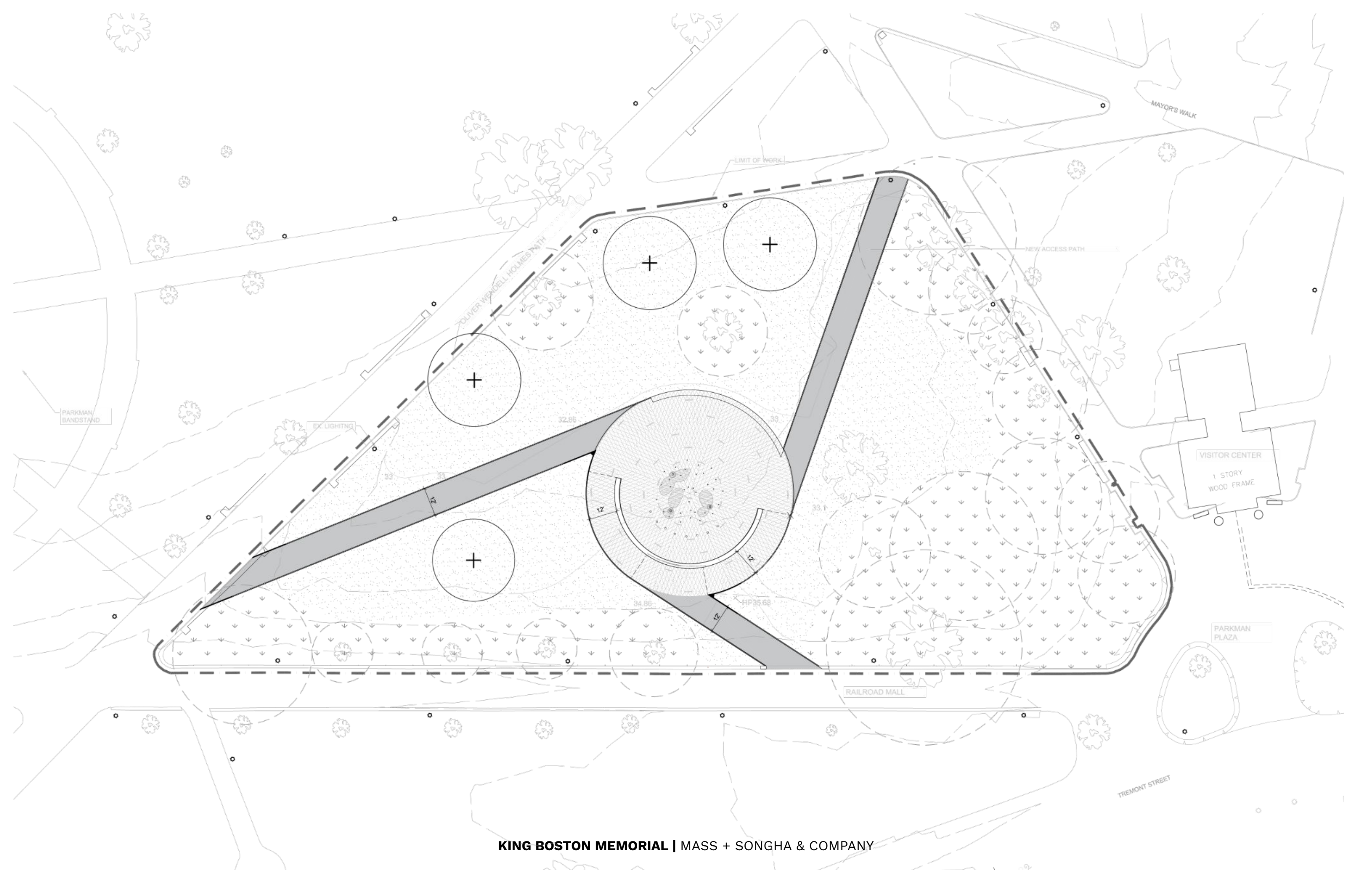

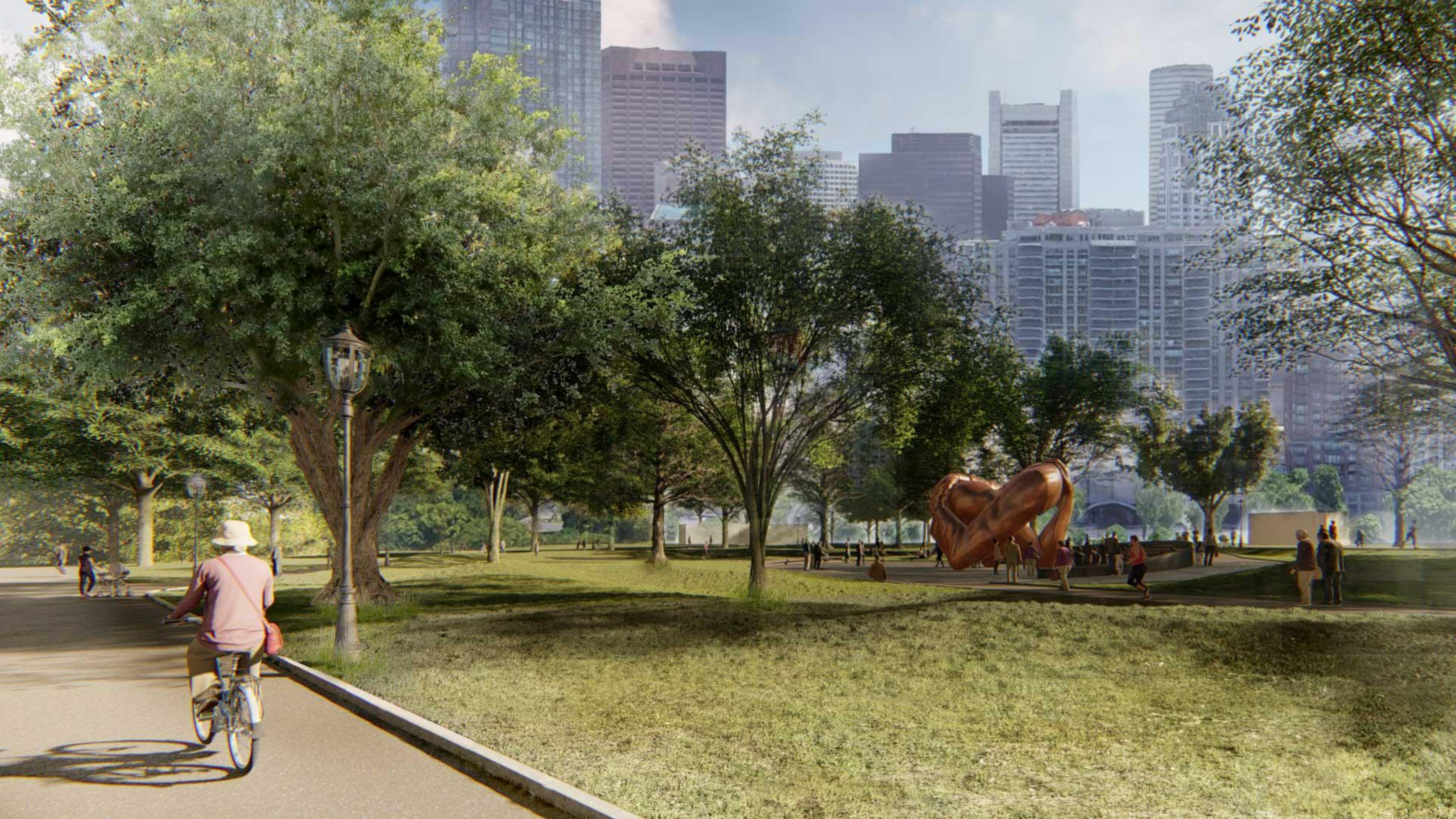

KING BOSTON MEMORIAL | MASS + SONGHA & COMPANY

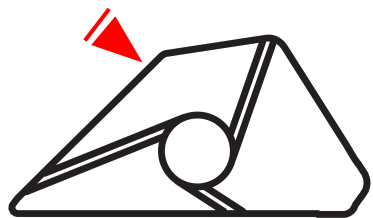

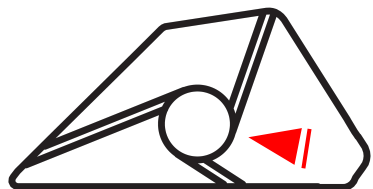

Plaza Plan

“In a real sense all life is interrelated. All men are caught in an inescapable network of mutuality, tied in a single **garment of destiny**.

Whatever affects one directly, affects all indirectly. I can never be what I ought to be until you are what you ought to be, and you can never be what you ought to be until I am what I ought to be...

This is the inter-related structure of reality.”

Martin Luther King Jr., Letter from the Birmingham Jail



Peace Walk

Collective action is usually forgotten. This project is an exceptional opportunity to tell the story of the Boston people that in their fight for social rights marched with King during the **1965 Freedom Rally**.

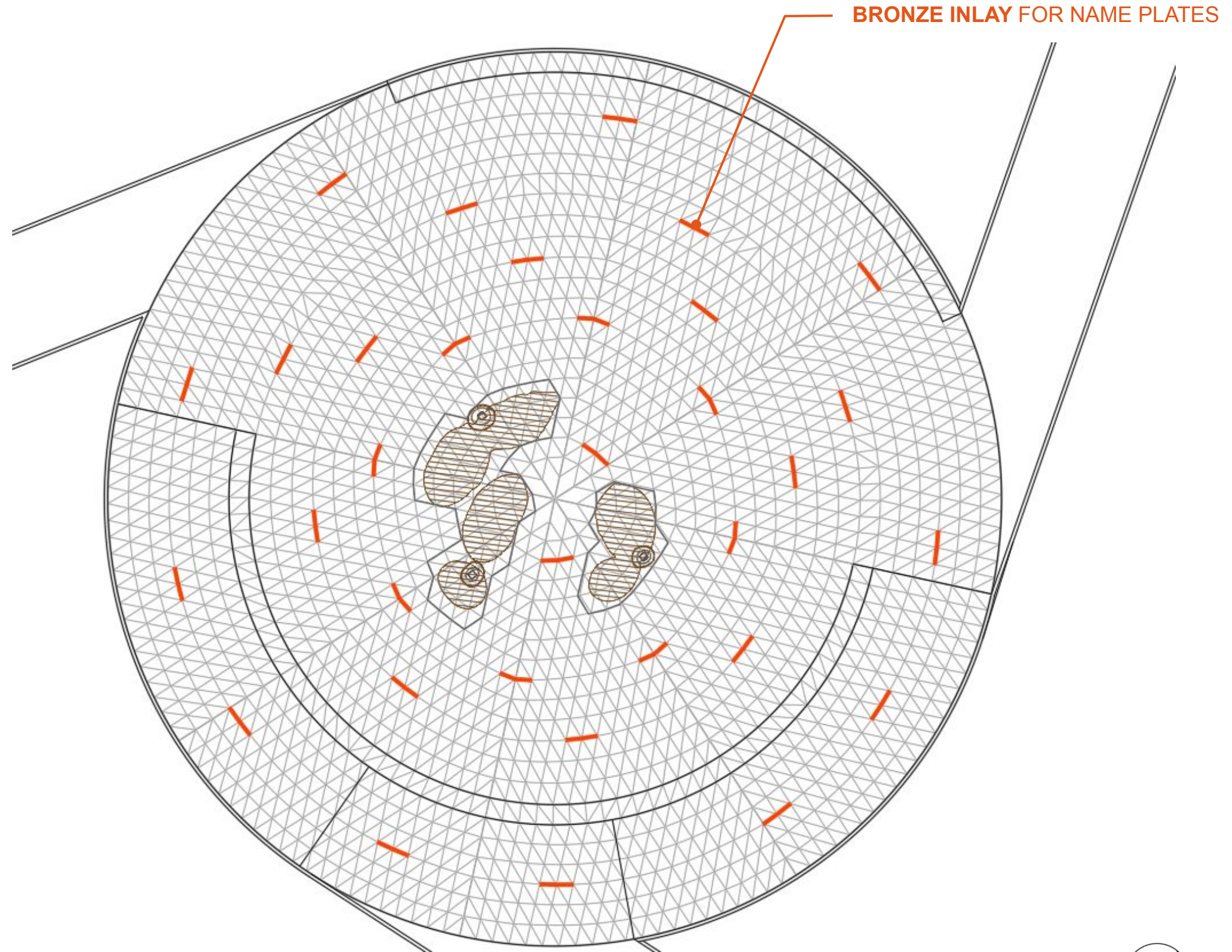

Paving and Bronze Inlays

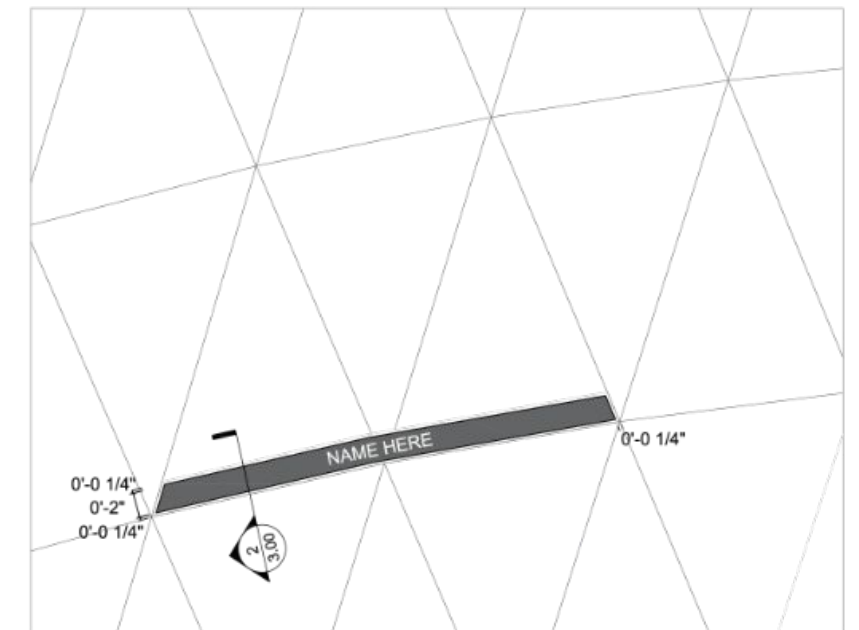
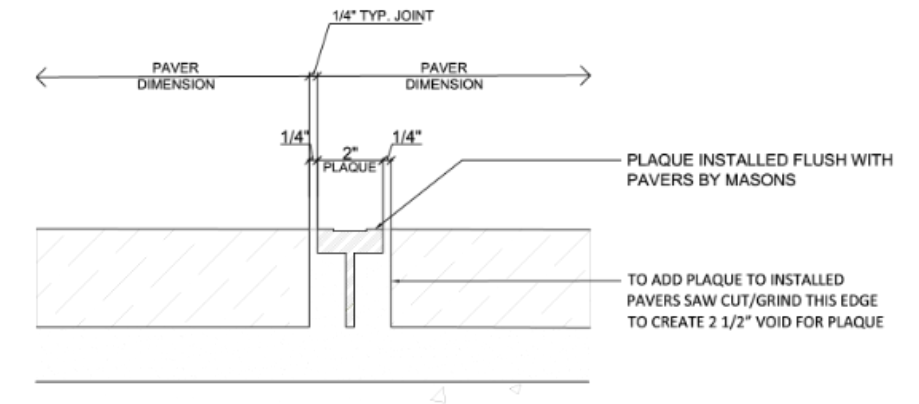
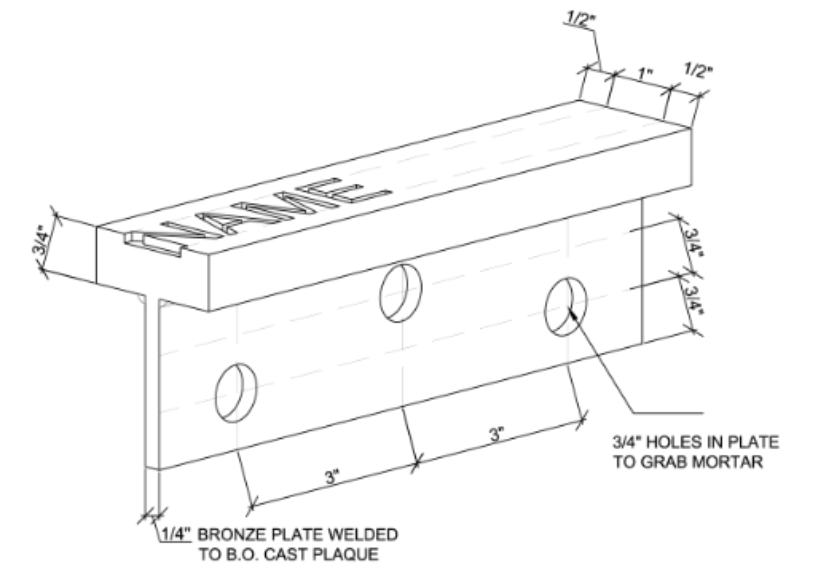
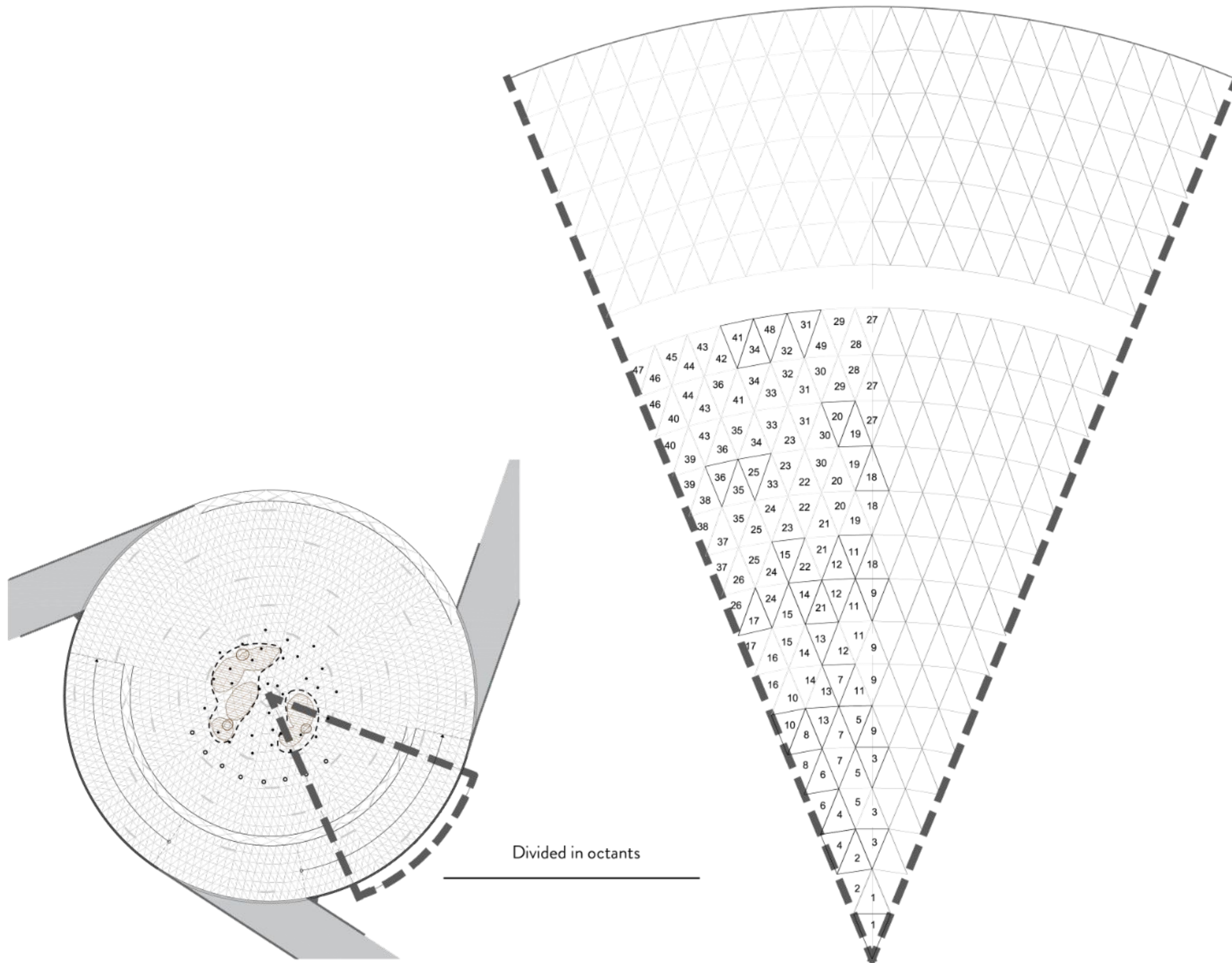

Boston Civil Rights Community



Michael E. Haynes

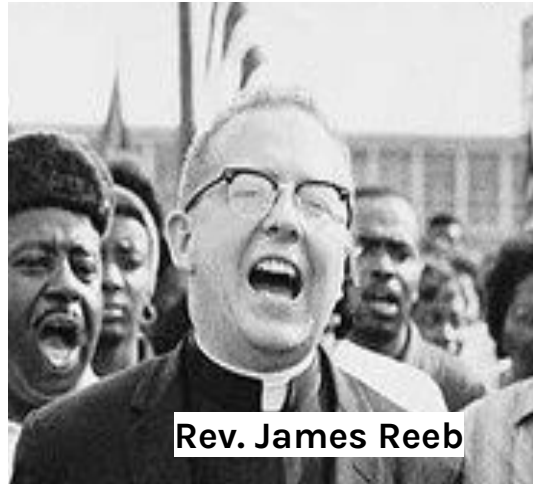

Rev. James Reeb

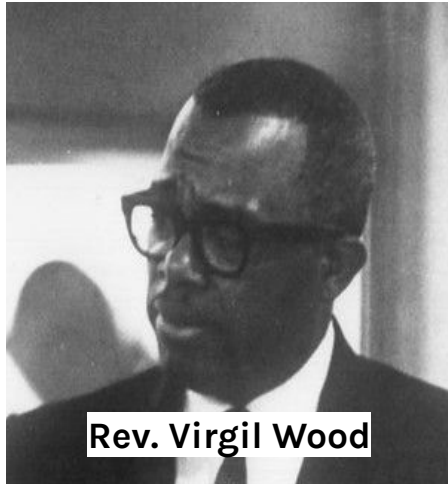

Rev. Virgil Wood



Rev. James P. Breeden

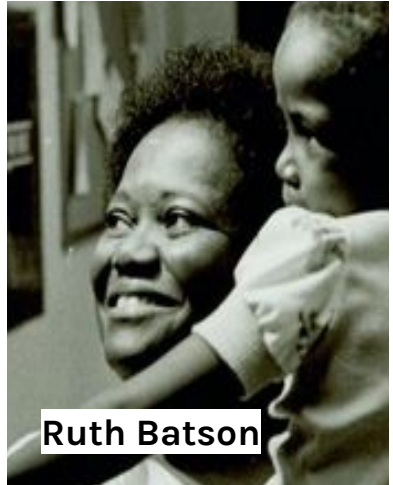

Ruth Batson

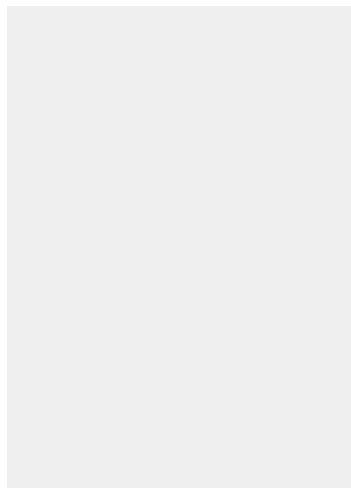
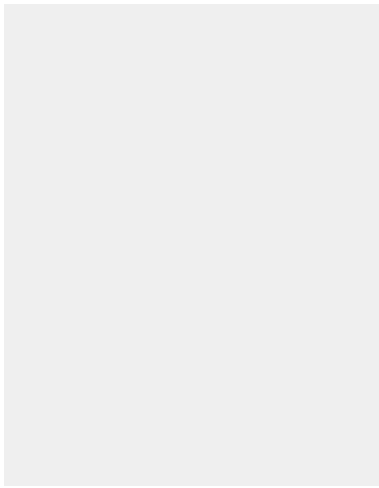
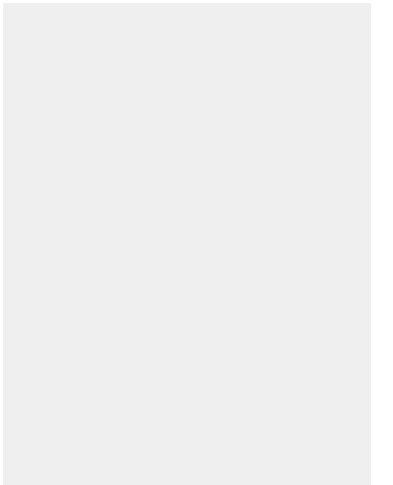

Otto P. and Muriel S. Snowden



Margaret Moseley

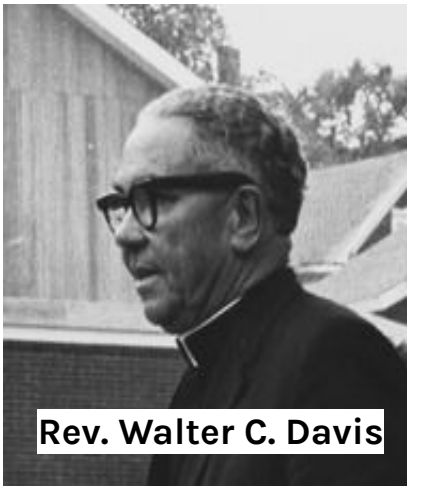

Rev. Walter C. Davis

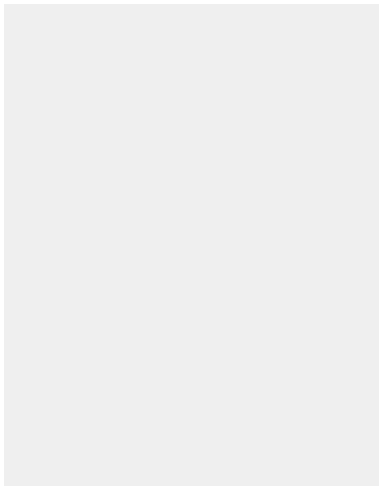

Rev. Vernon Carter

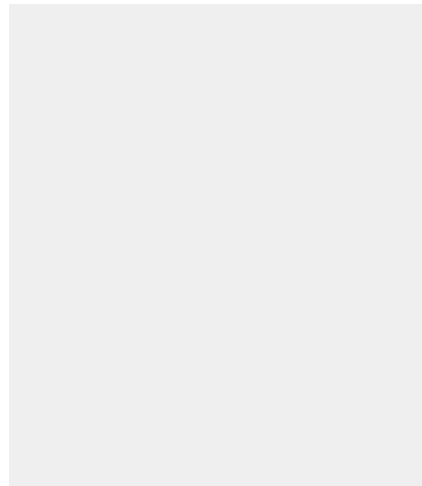

Sarah-Ann Shaw

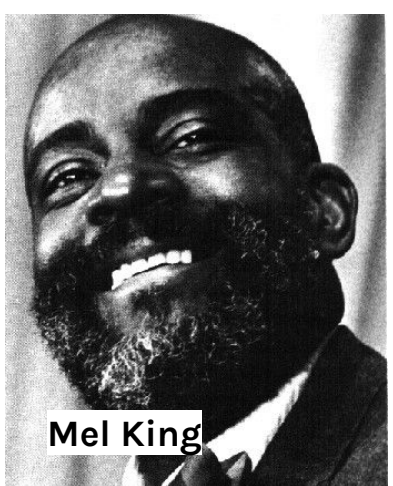
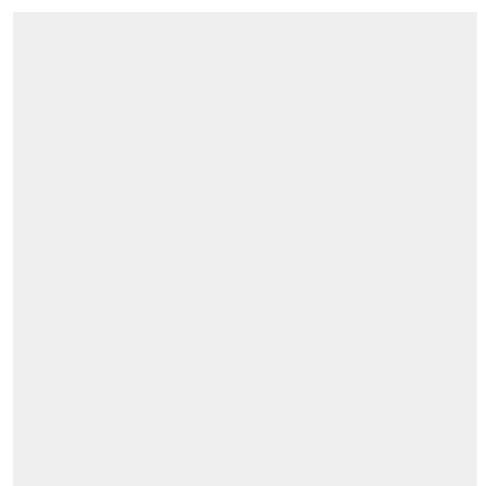

Mel King

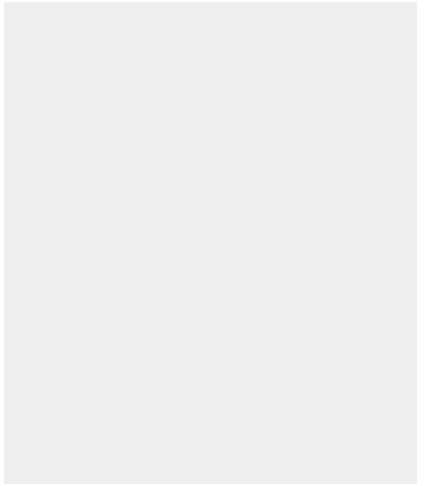

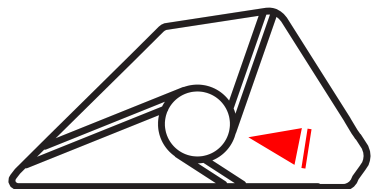
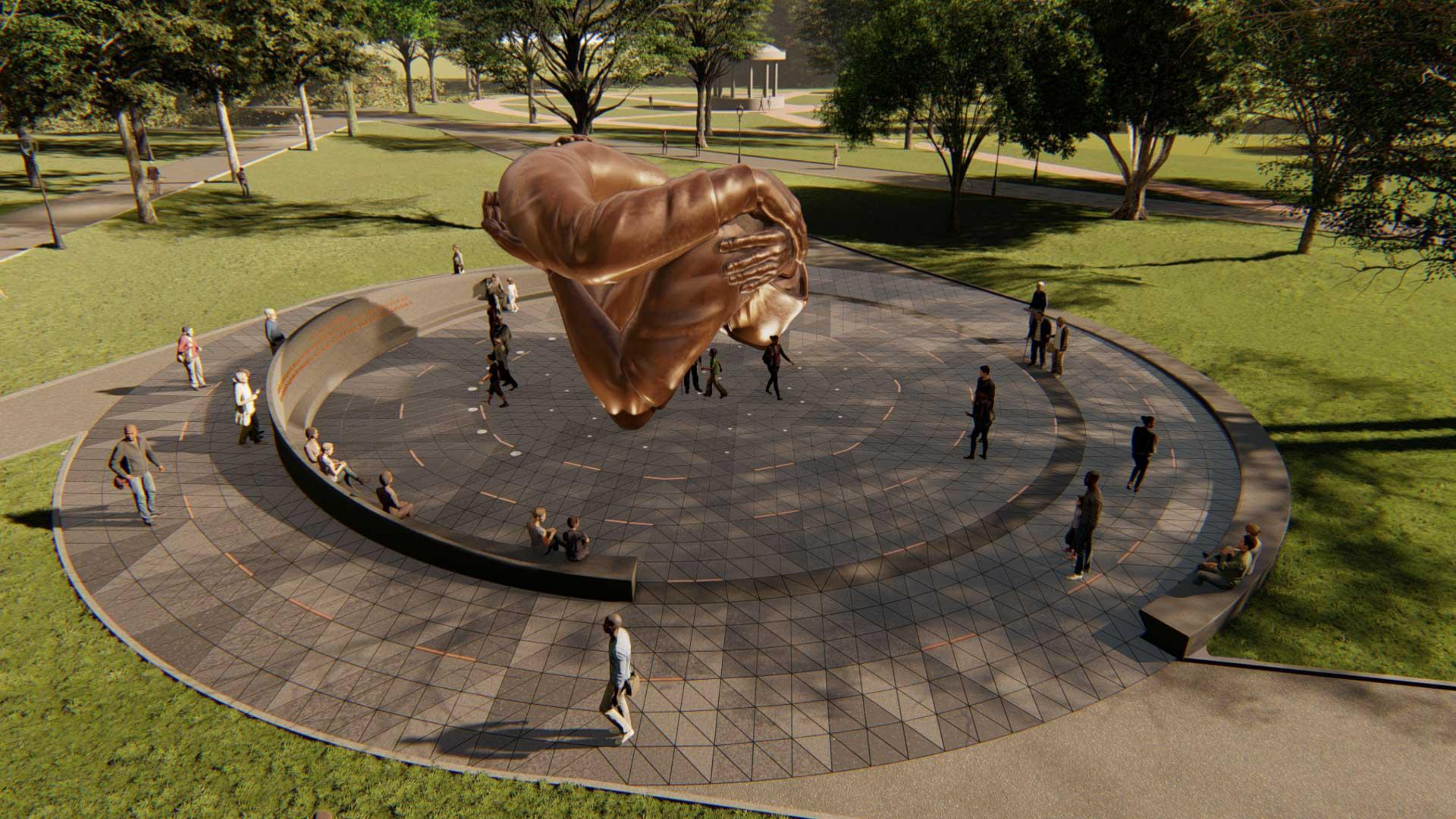

Quote Wall / Bench

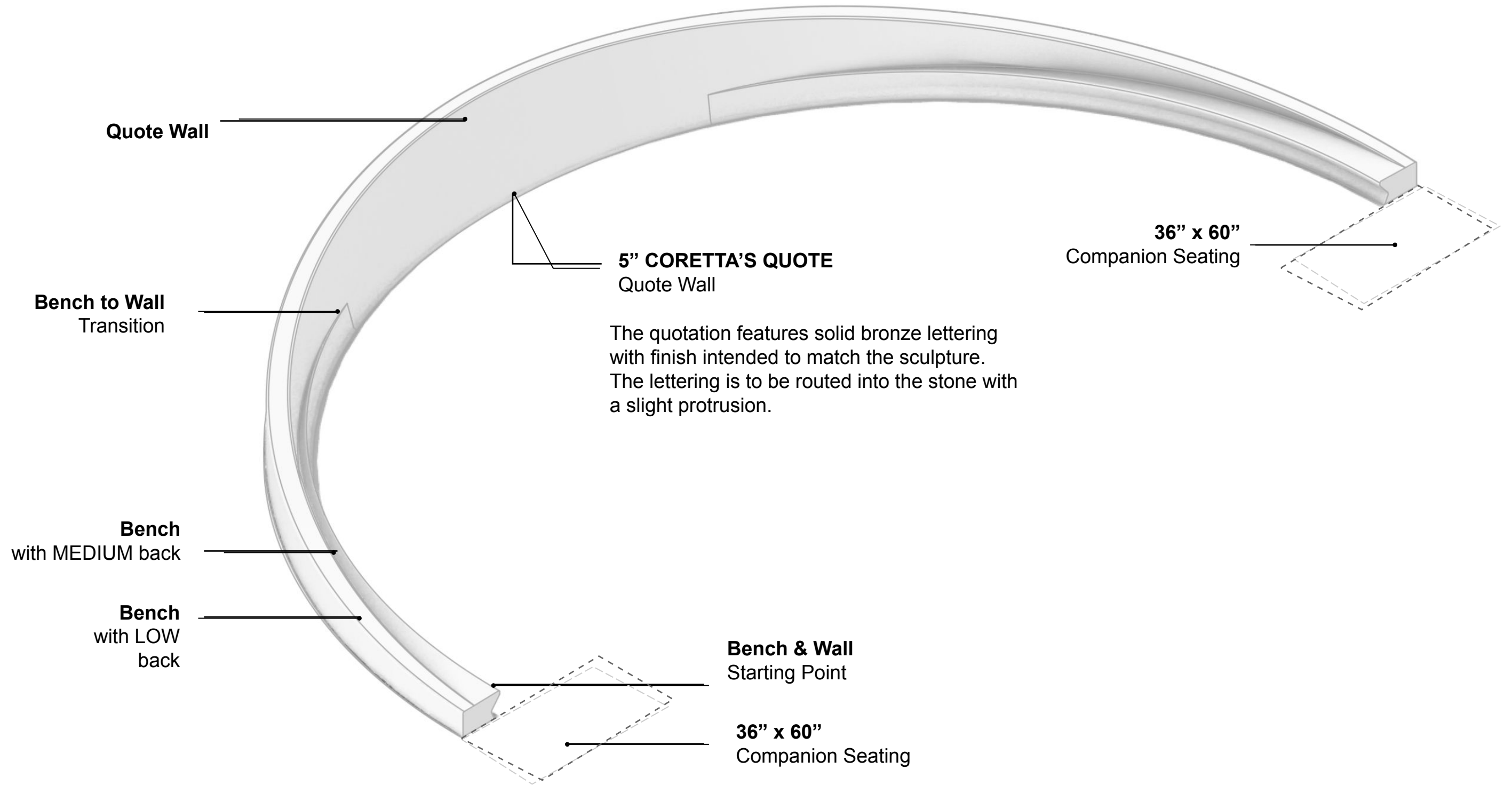

Quote Wall / Bench

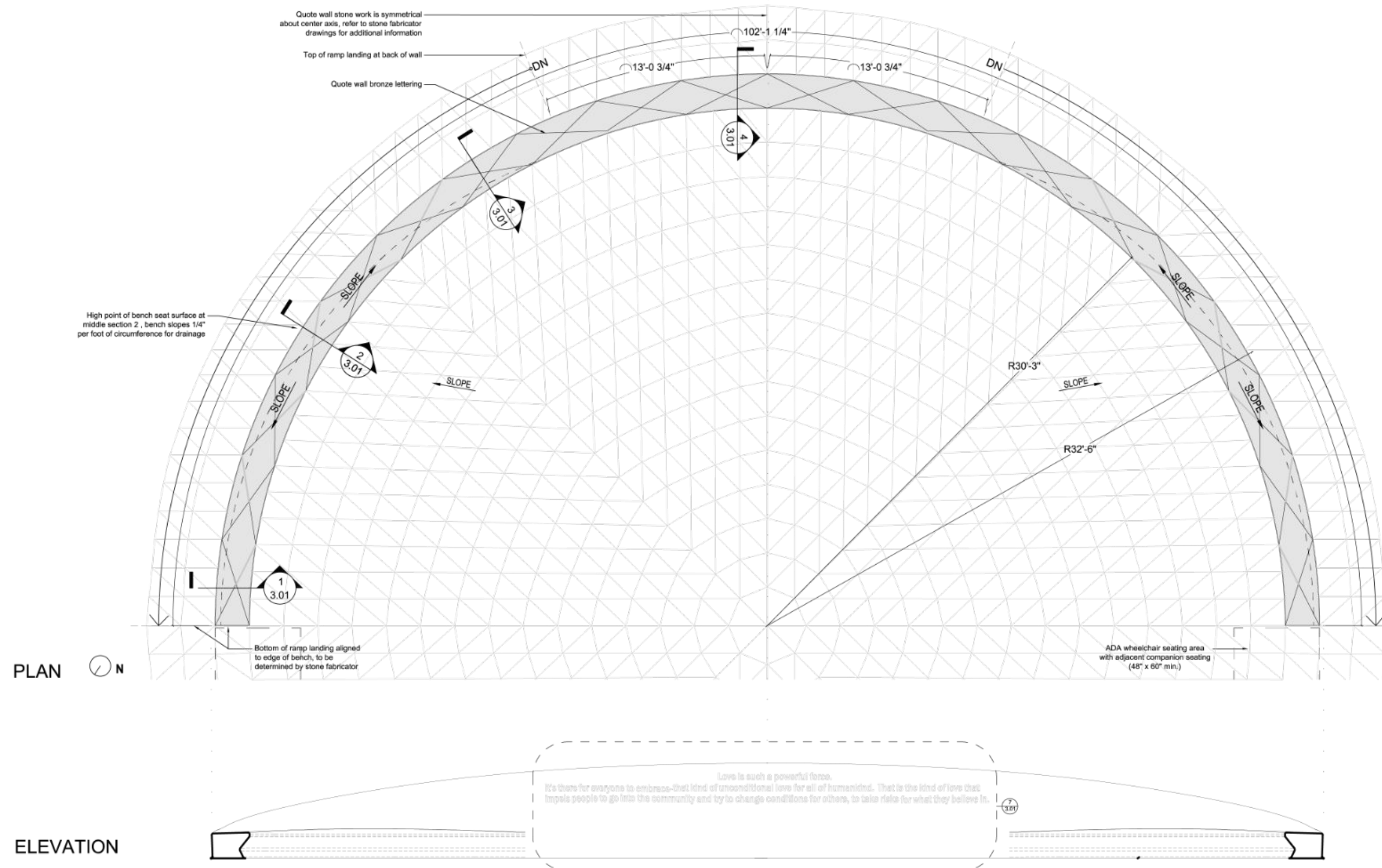

Quote Wall / Bench

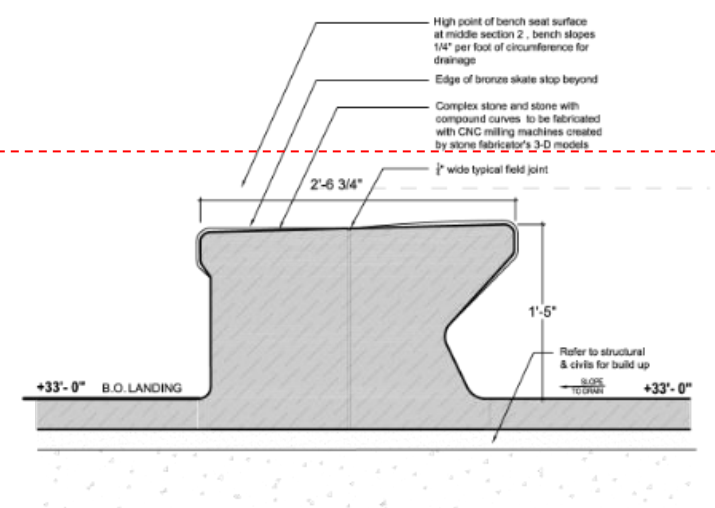
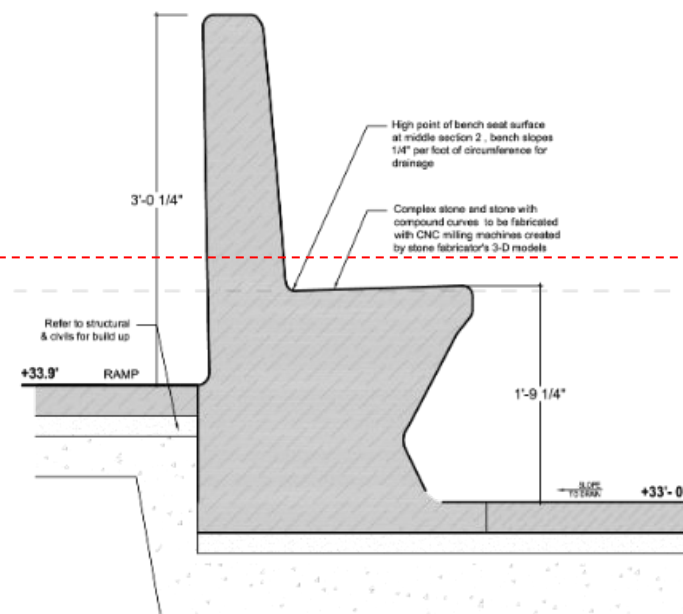
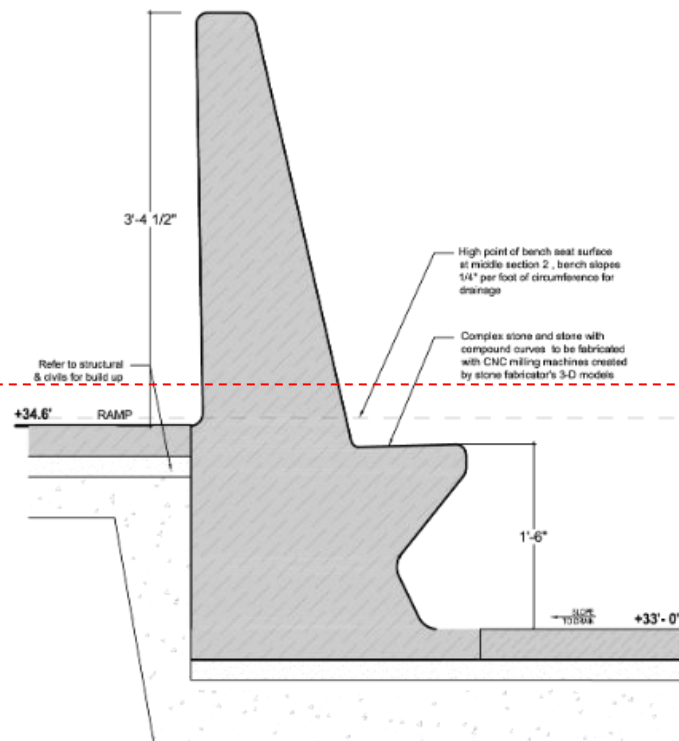
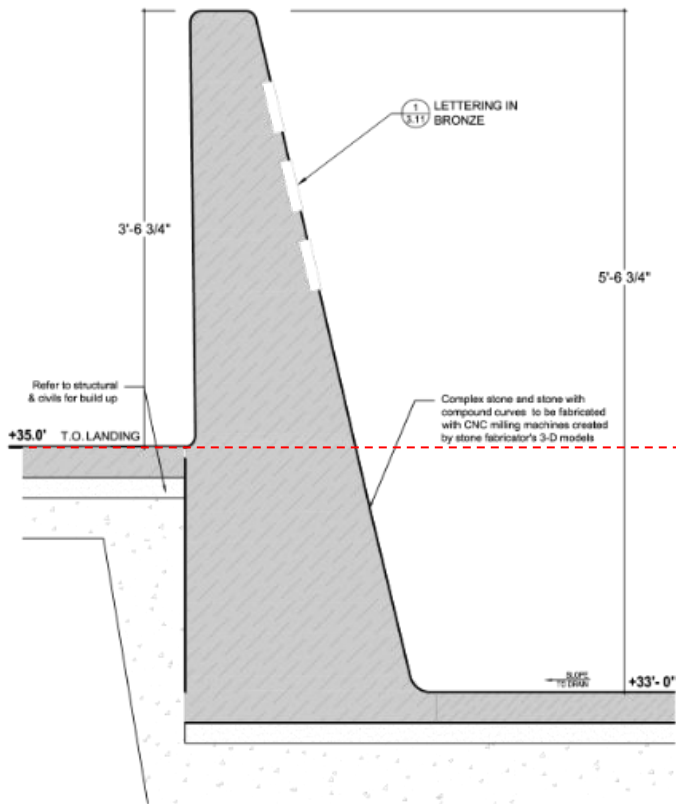
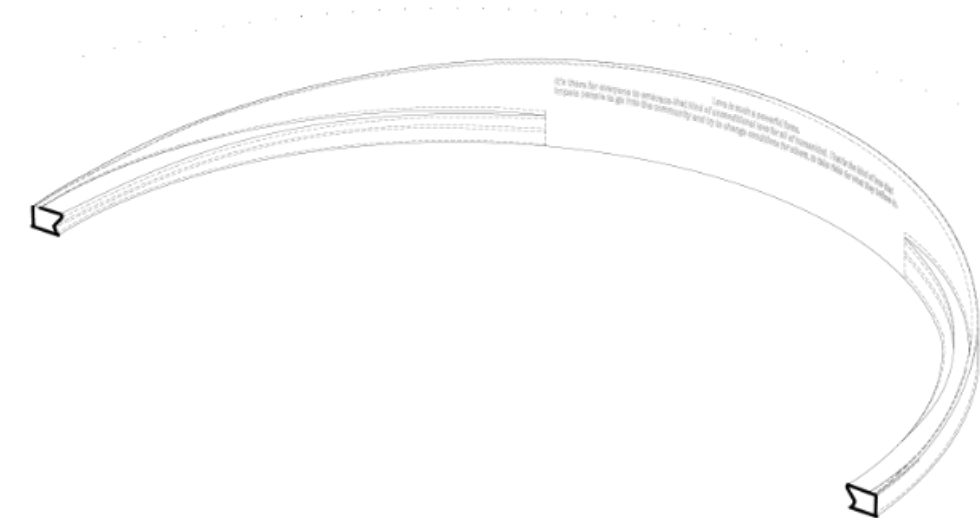
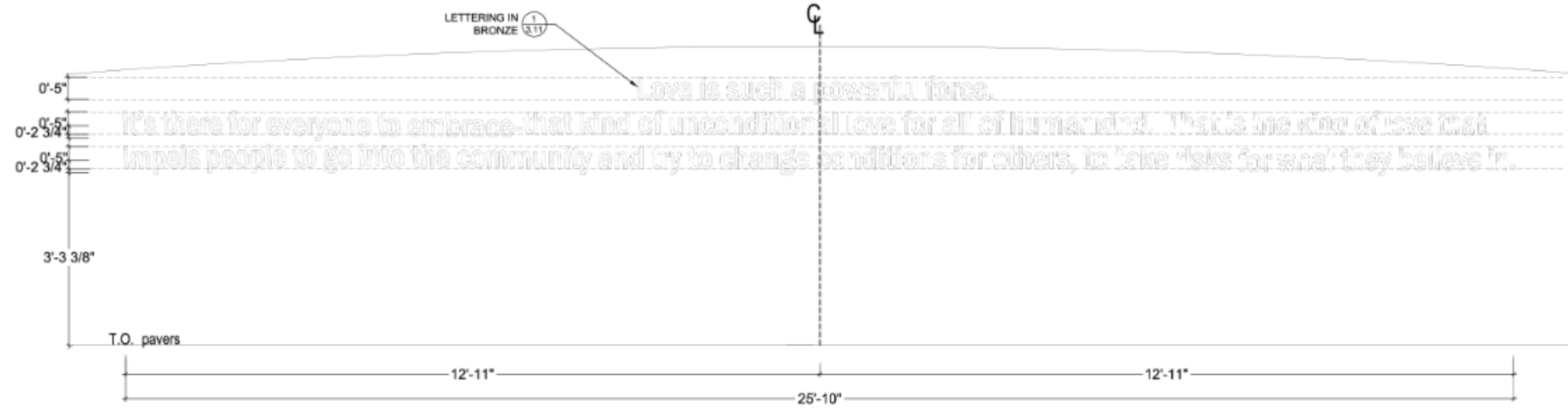



It is such a powerful force.
conditional love for all of humankind. That is the law
to change conditions for others, to take risks for who

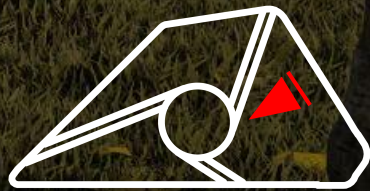

ARTWORK AT BASE

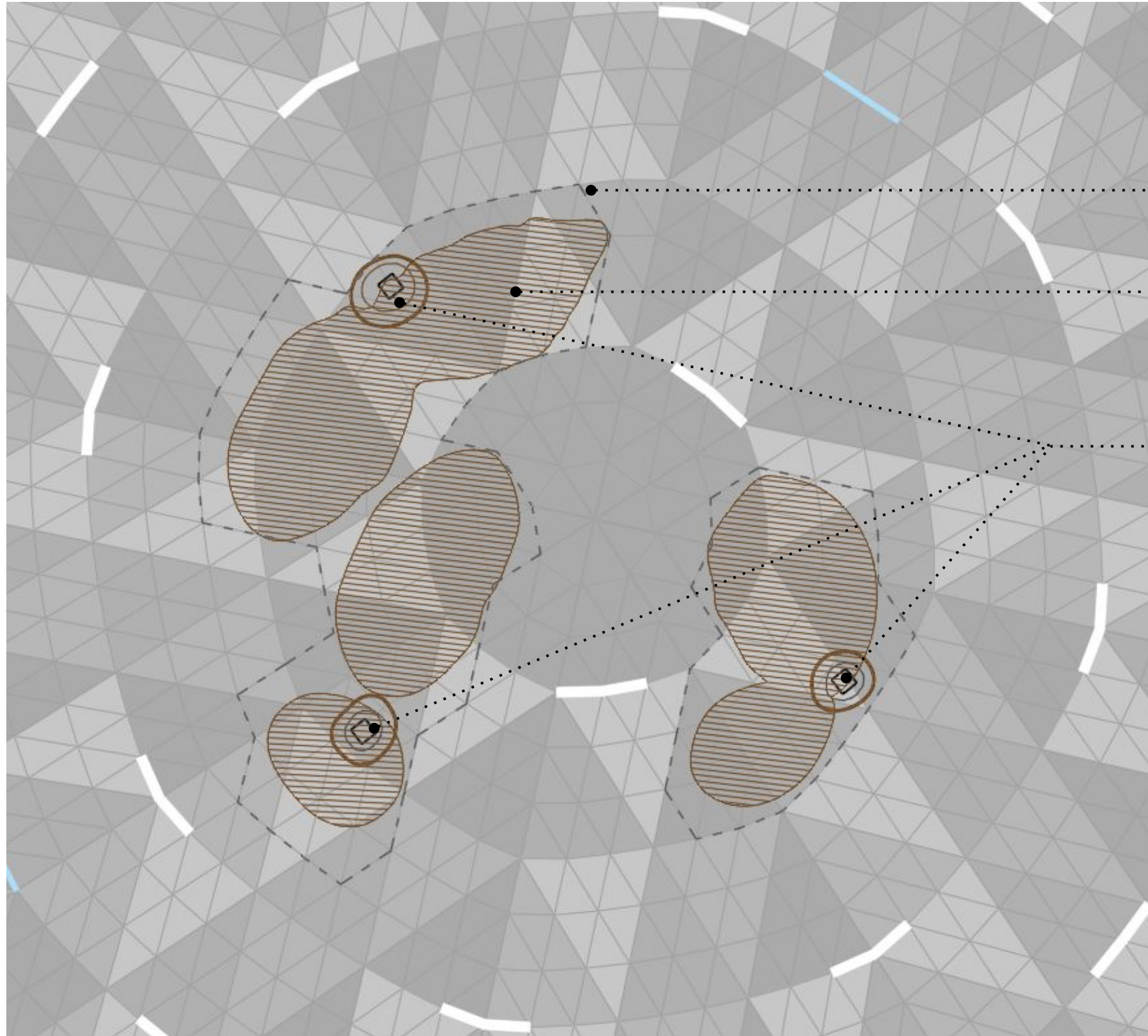

Cane Detection Limit
Tactile bumps

ARTWORK SECTION AT 6'-8"
(minimum head clearance)

ARTWORK FOOTING
(X 3)

Tactile bumps in stone



LIGHTING

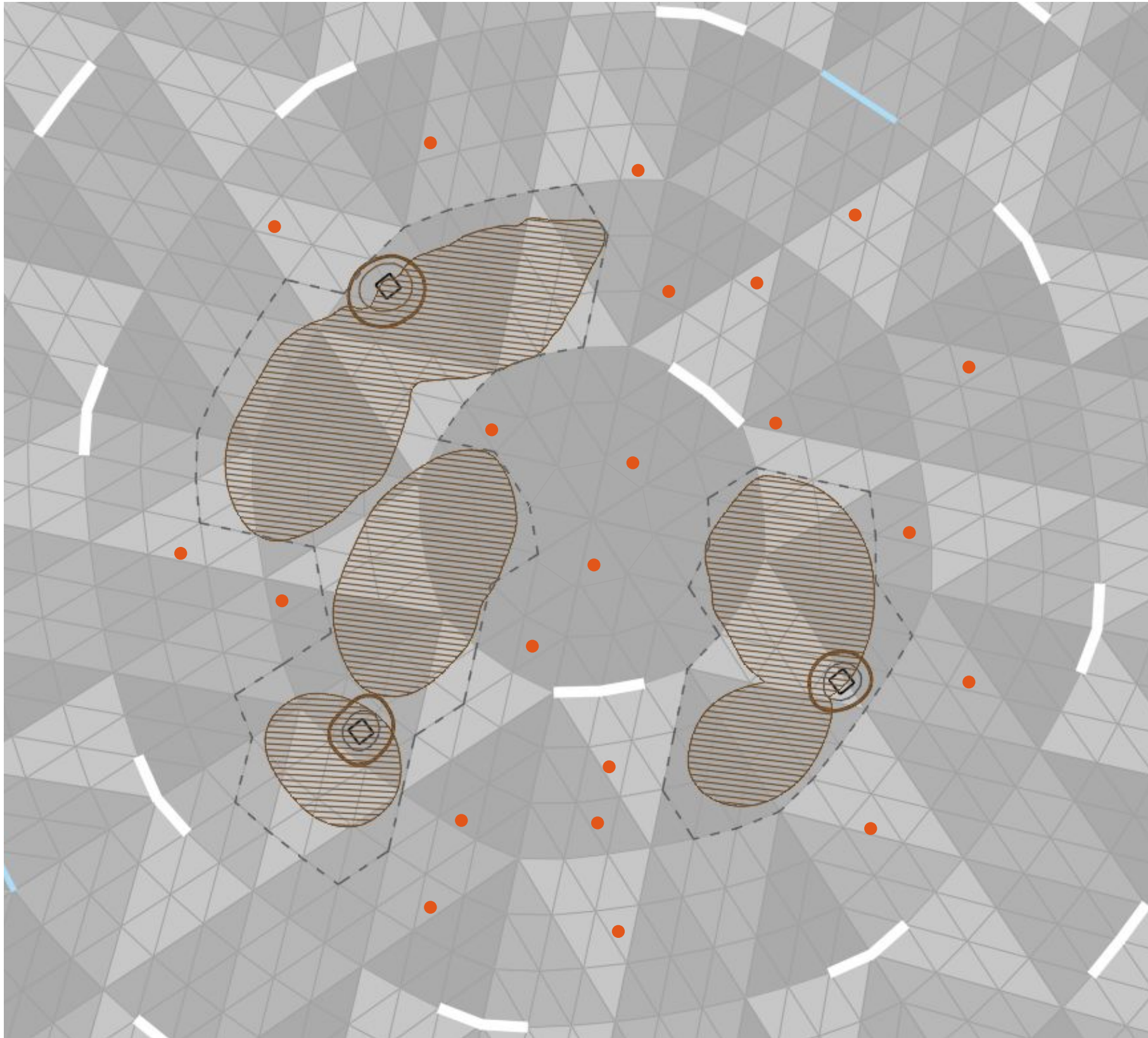

**INGRADE, SMALL APERTURE
UPLIGHTS ASYMMETRICALLY DISTRIBUTED**

LIGHTING

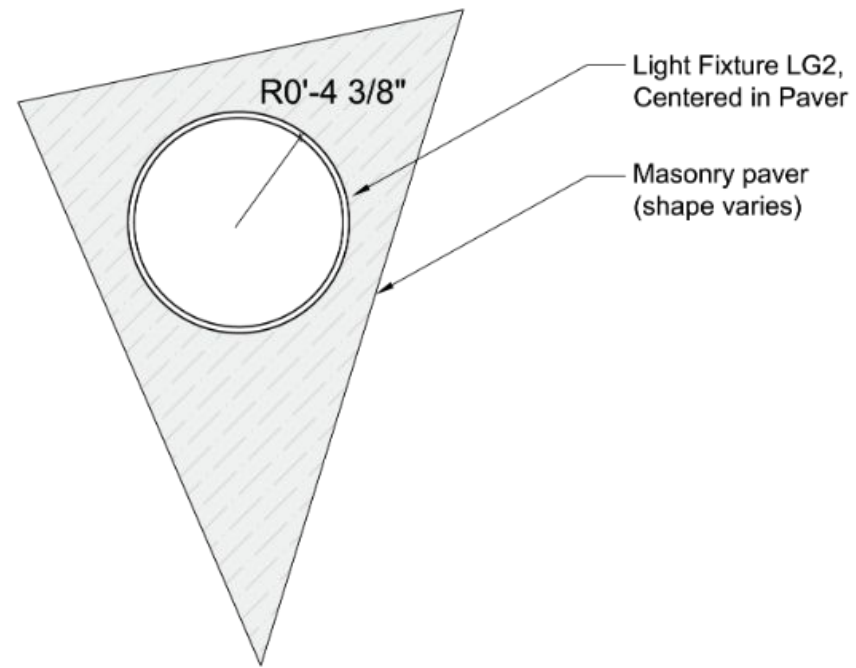

LG2 PLAN

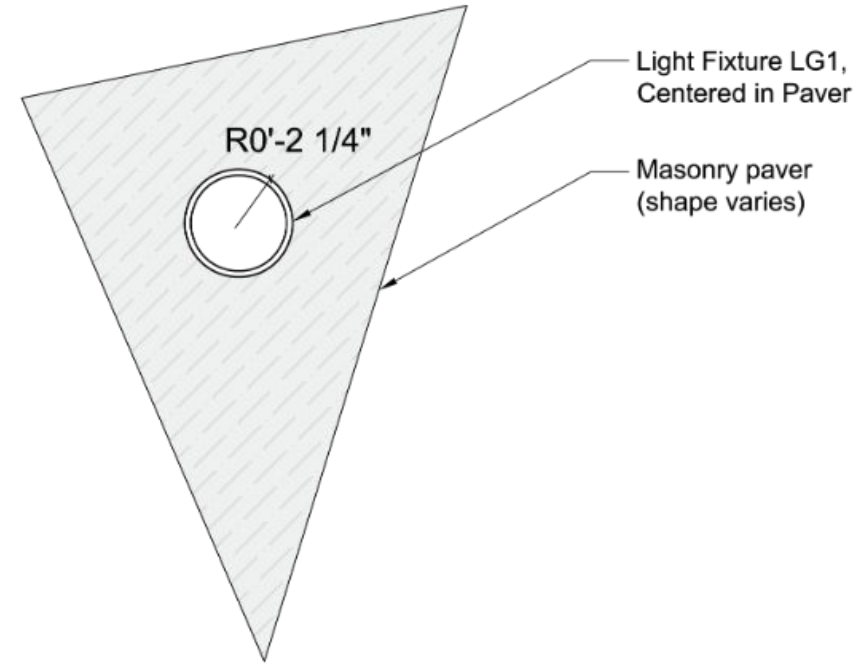

LG1 PLAN

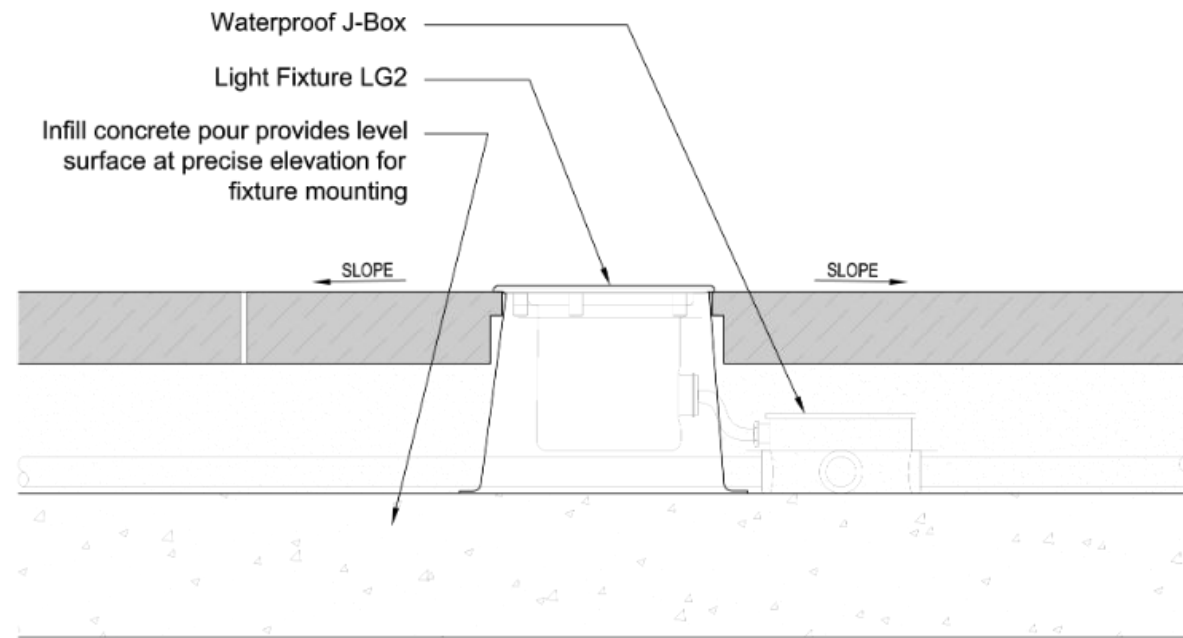

ELEVATION

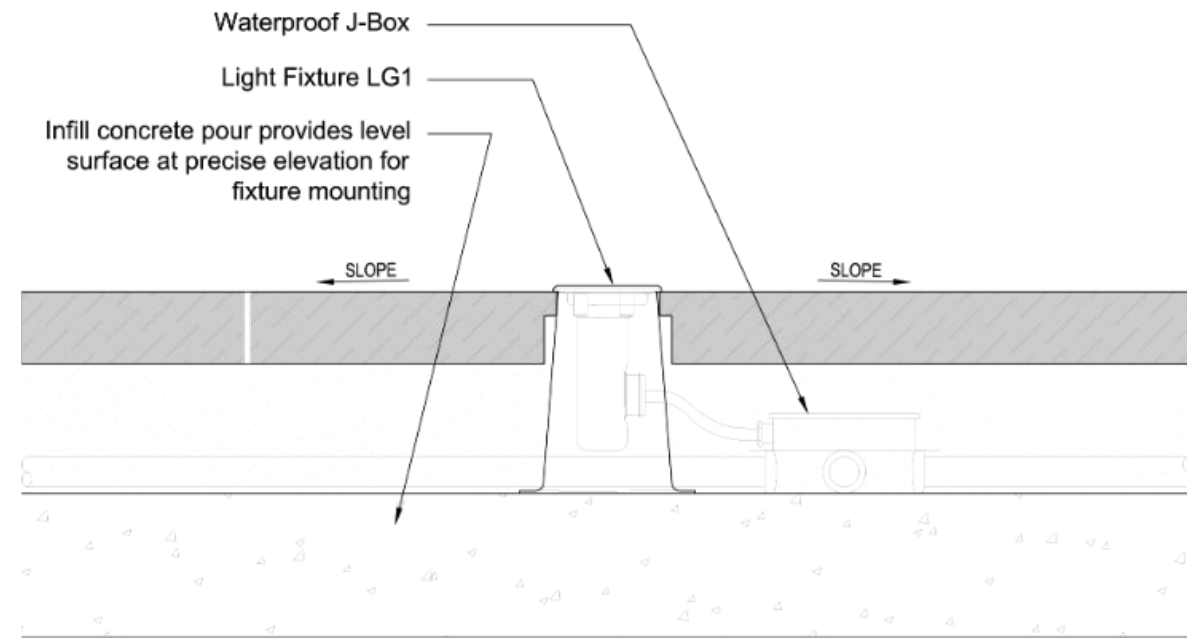

ELEVATION

SCULPTURE

TYPICAL

- STRUCTURAL SLAB PITCHES TO DRAIN
- PAVER SURFACE PITCHES TO DRAIN
- TYPICAL MORTAR BED IS 2"
- TYPICAL PAVERS ARE 3"

AT THE PLAZA CENTER

- STRUCTURAL SLAB IS FLAT
- PAVER SURFACES PITCH AWAY FROM THE ELBOWS
- THE MORTAR+PAVER DEPTH VARIES BETWEEN 5" AT ITS LOWEST AND 6" DIRECTLY UNDER THE ELBOWS

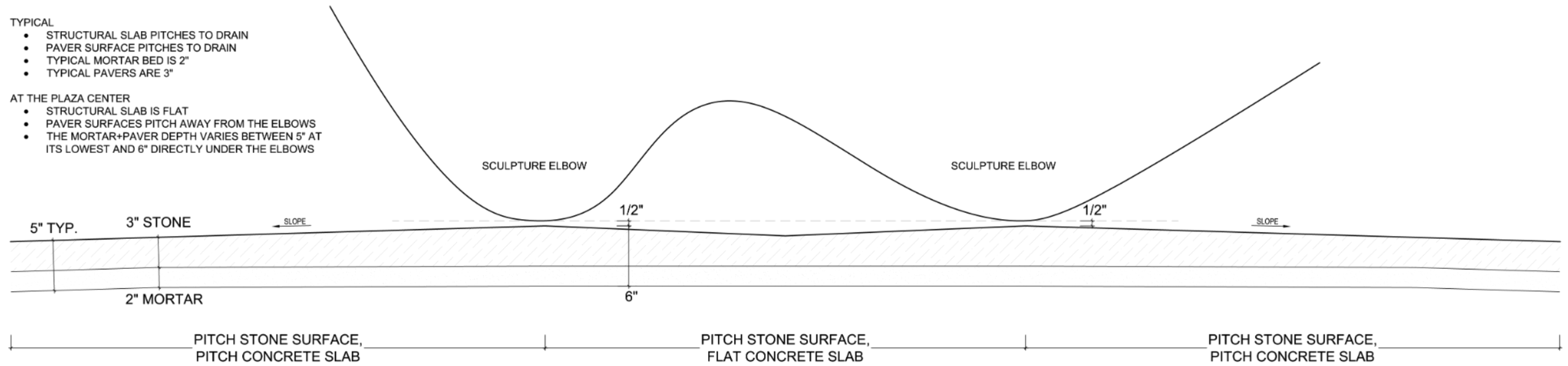

SCULPTURE BASE DRAINAGE

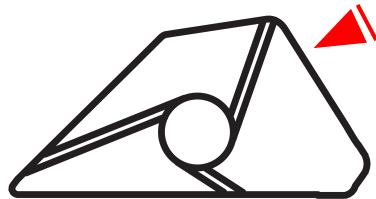

Bench

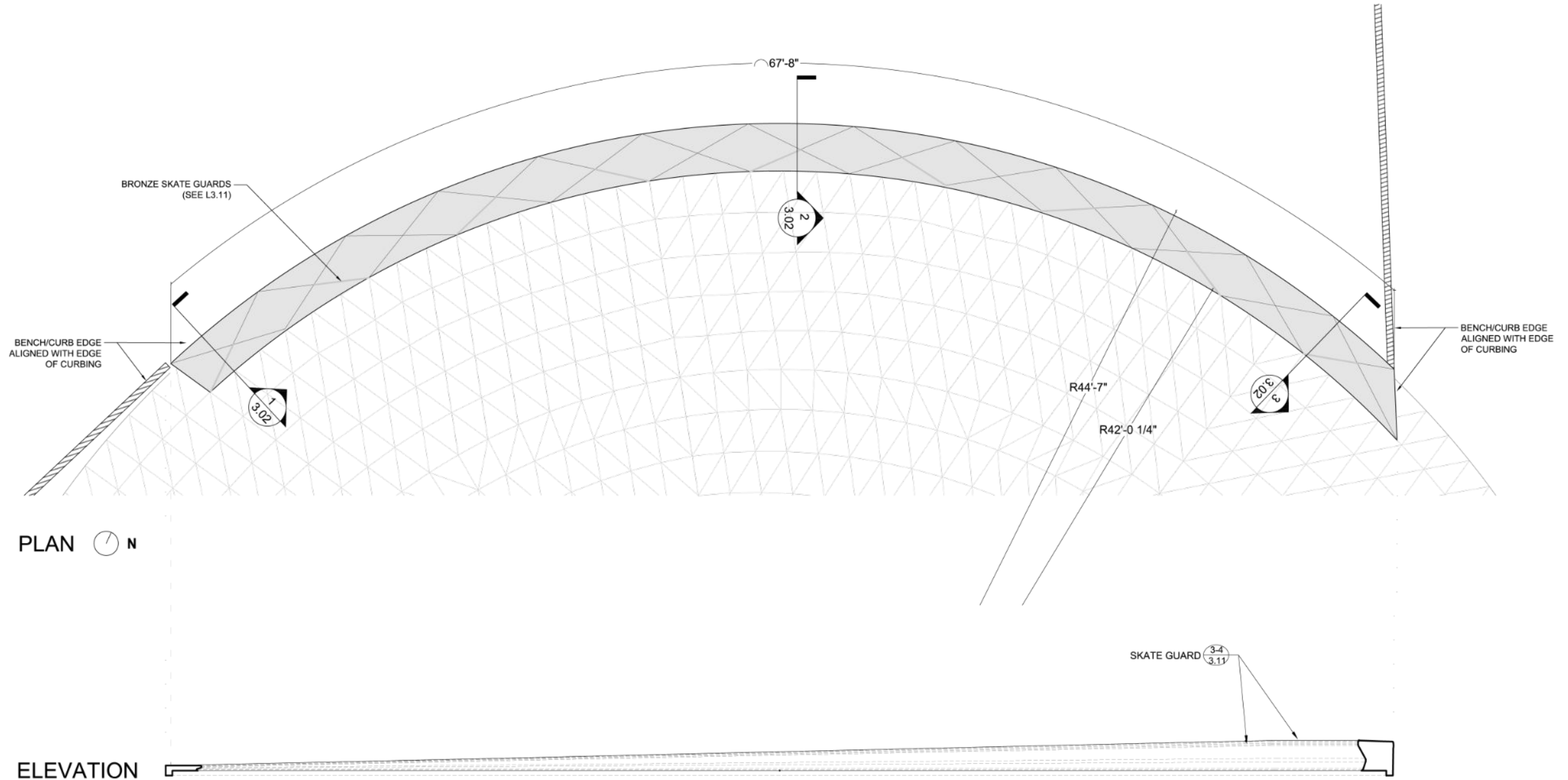

Bench

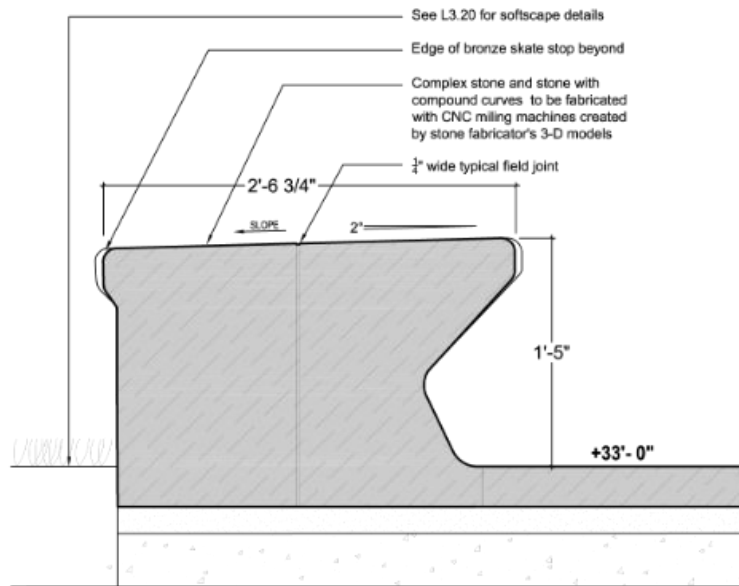
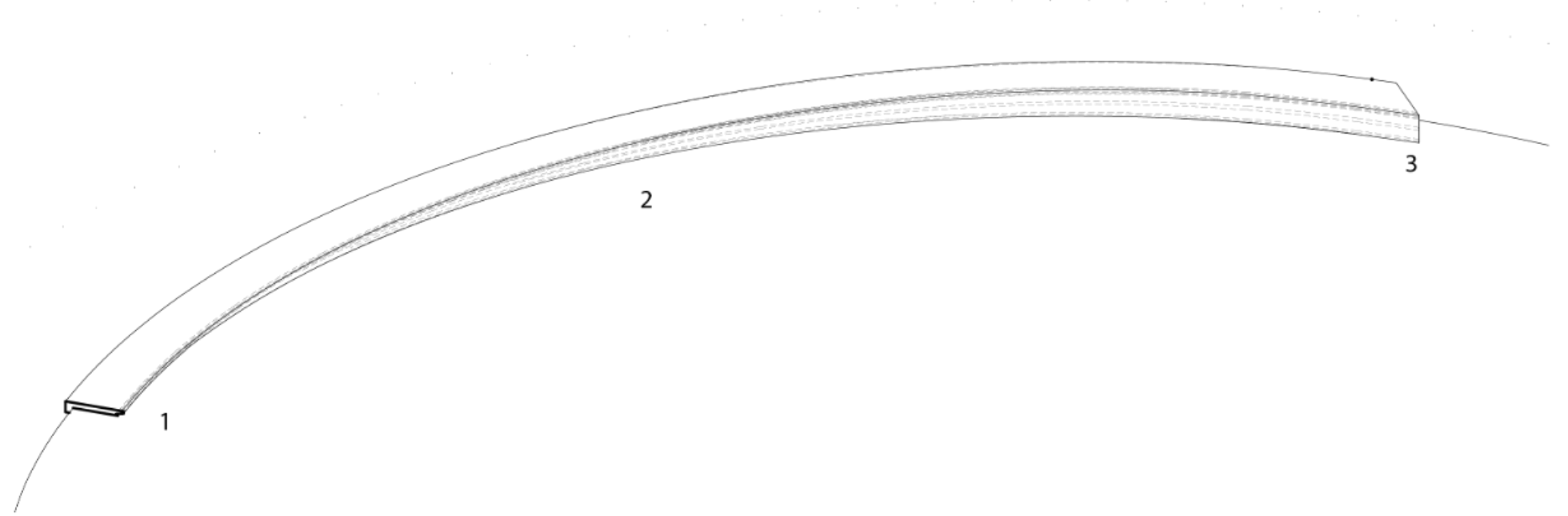

BENCH CURB SECTION 3

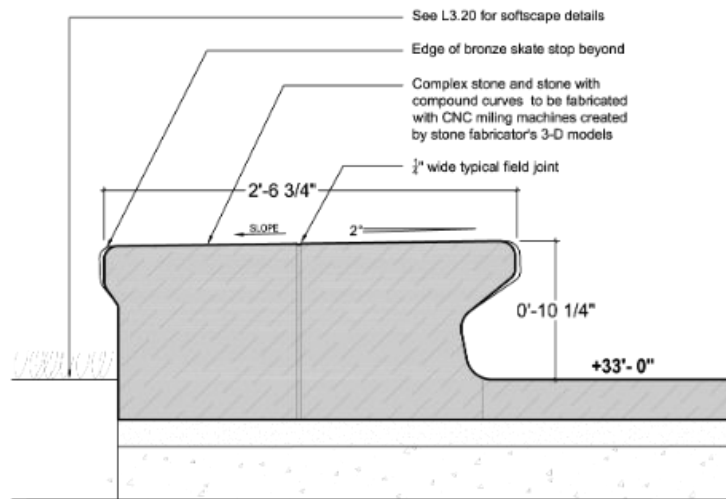

BENCH CURB SECTION 2

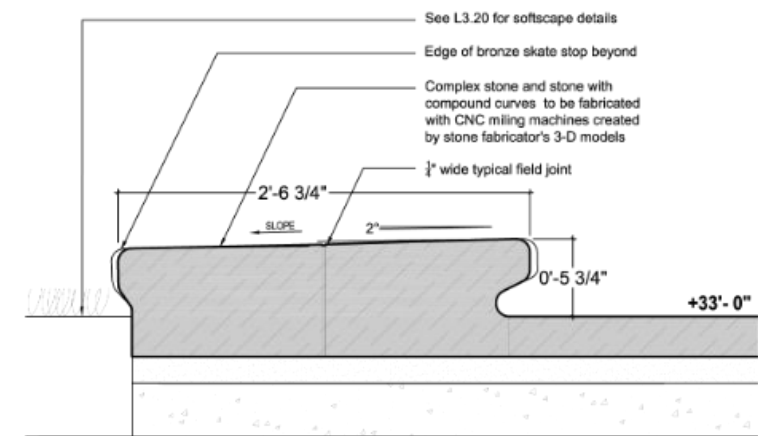

BENCH CURB SECTION 1

