

# THE FIRST CHURCH OF CHRIST, SCIENCE

## **Proposed Accessible Entry BLC Hearing**

September 28, 2021

**FINE GOLD  
ALEXANDER**  
ARCHITECTS



# TFCCS Site Plan

## Challenge

Currently, there is only one elevator that services the plaza from the garage, which is how a majority of the congregation arrives at the church. The elevator is located at the far north end of the complex, making it difficult for anyone that needs assistance from the garage to the plaza to access it.

## Project Goal

Create a welcoming, accessible entrance in a central arrival location between TMCX and TMCO for the congregation and visitors to allow 24/7 access from the garage and the plaza.

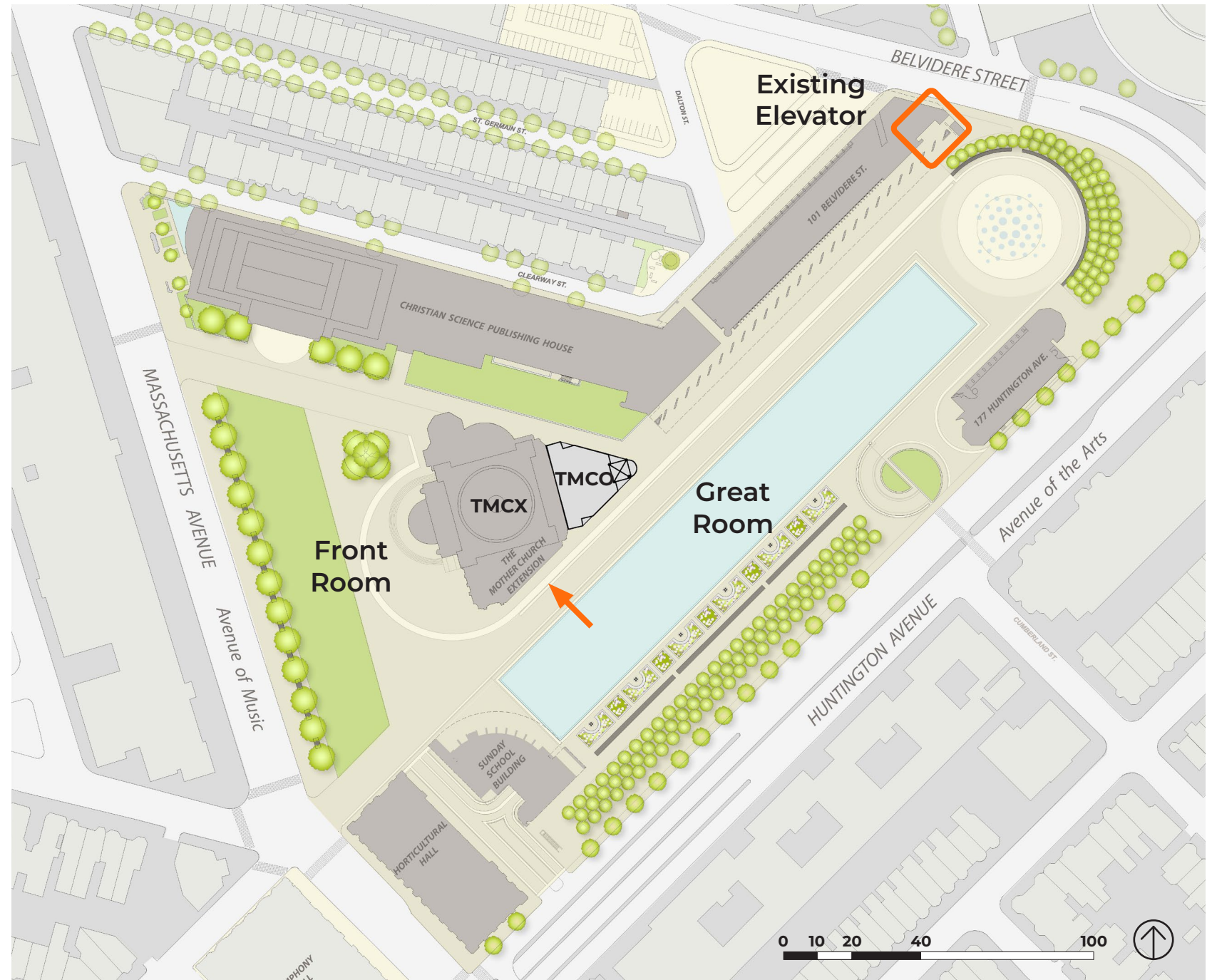

# Existing Elevations



**WEST ELEVATION**



**SOUTH ELEVATION**

# Existing Glazing



# Proposed Portico Infill Area

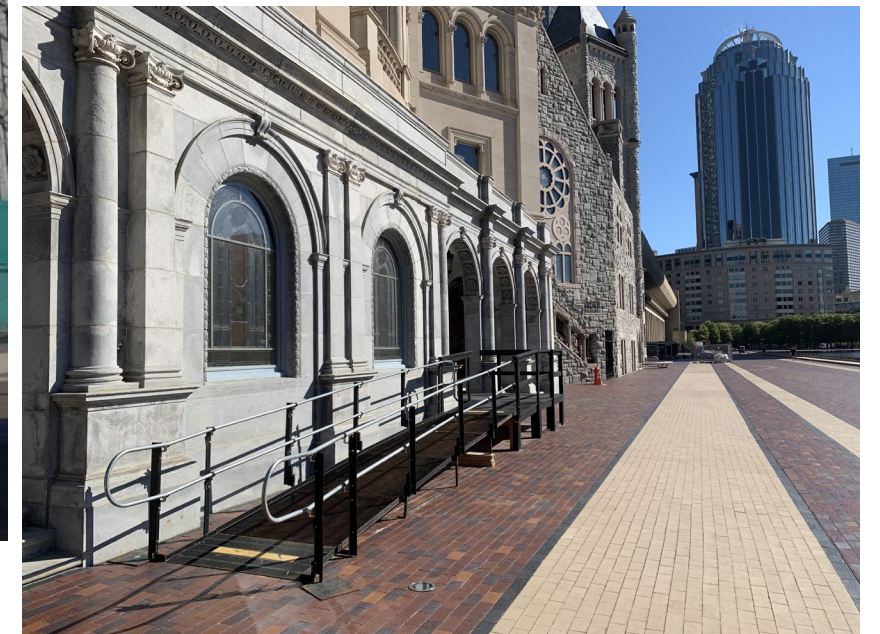

Existing Conditions with Temporary Ramp

# Existing Conditions

- 2'-0" elevation difference between the plaza level and the interior lobby.
- Pinchpoints at the north and south end arches of the portico.
- Arched Guastavino tiled ceiling to remain as existing.
- Decorative, detailed wall profiles at the base, imposts and tiled ceiling.
- Existing intricately carved wood doors at vestibule and future elevator openings.



Proposed Elevator – left,  
Existing Vestibule – right

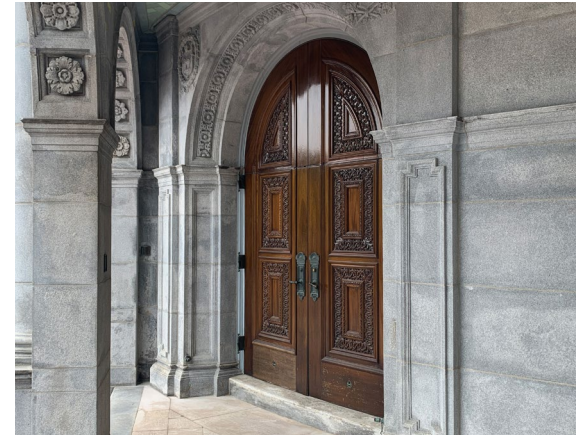

Proposed Elevator Location



Existing Wood Doors at Vestibule



Stone Detail and  
Guastavino Tiled Ceiling



Stone Pinchpoint at Base



Stone Pinchpoint at Impost

# Precedent Images



**CAMBRIDGE PUBLIC LIBRARY  
ANN BEHA ARCHITECTS**

**TMCX PORTICO ENTRY DOOR**



**CHICAGO ART INSTITUTE**

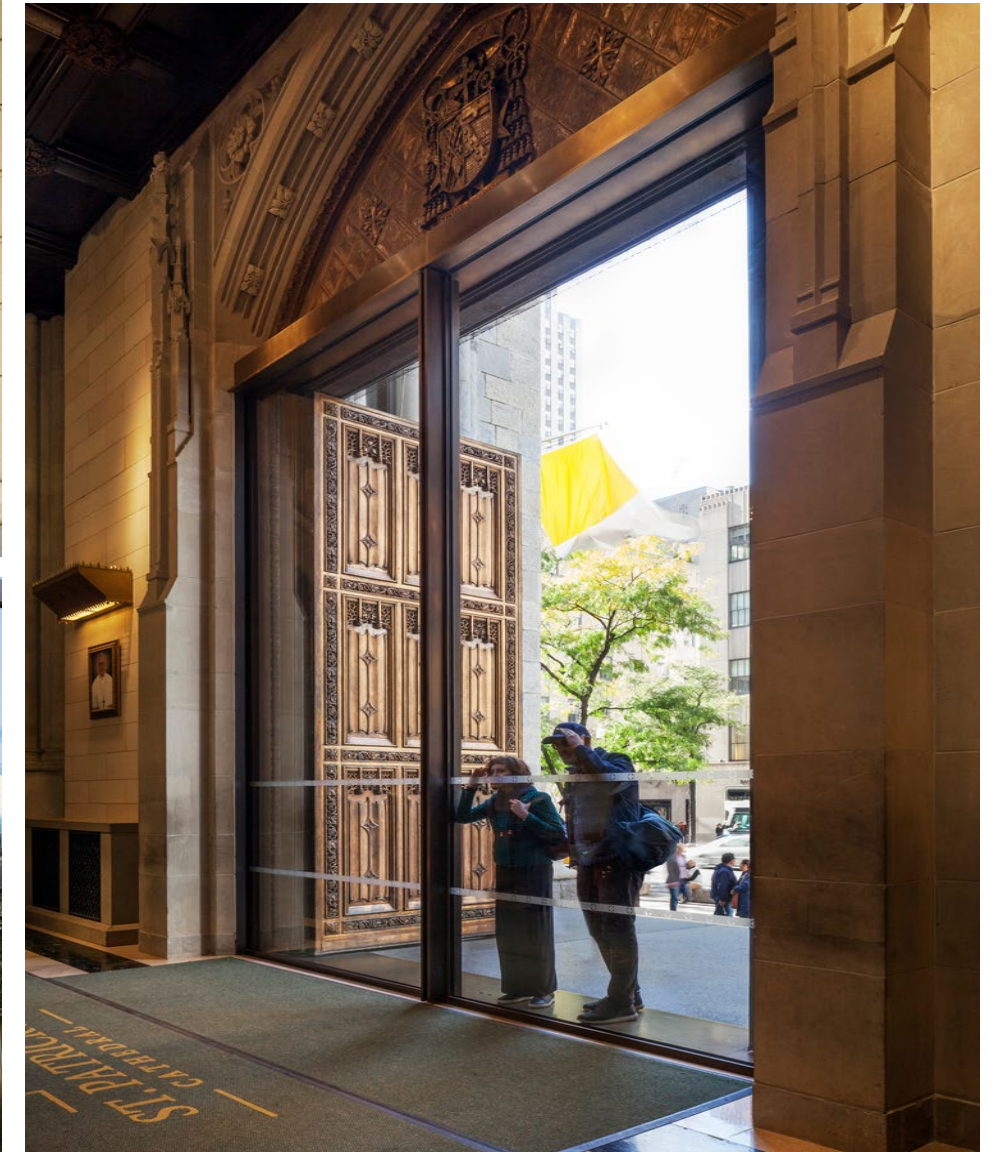

**ST. PATRICK'S CATHEDRAL  
MBB ARCHITECTS**

# Original Design Concept

Presented at July 27, 2021 Boston Landmarks Commission Hearing



# Original Design Concept

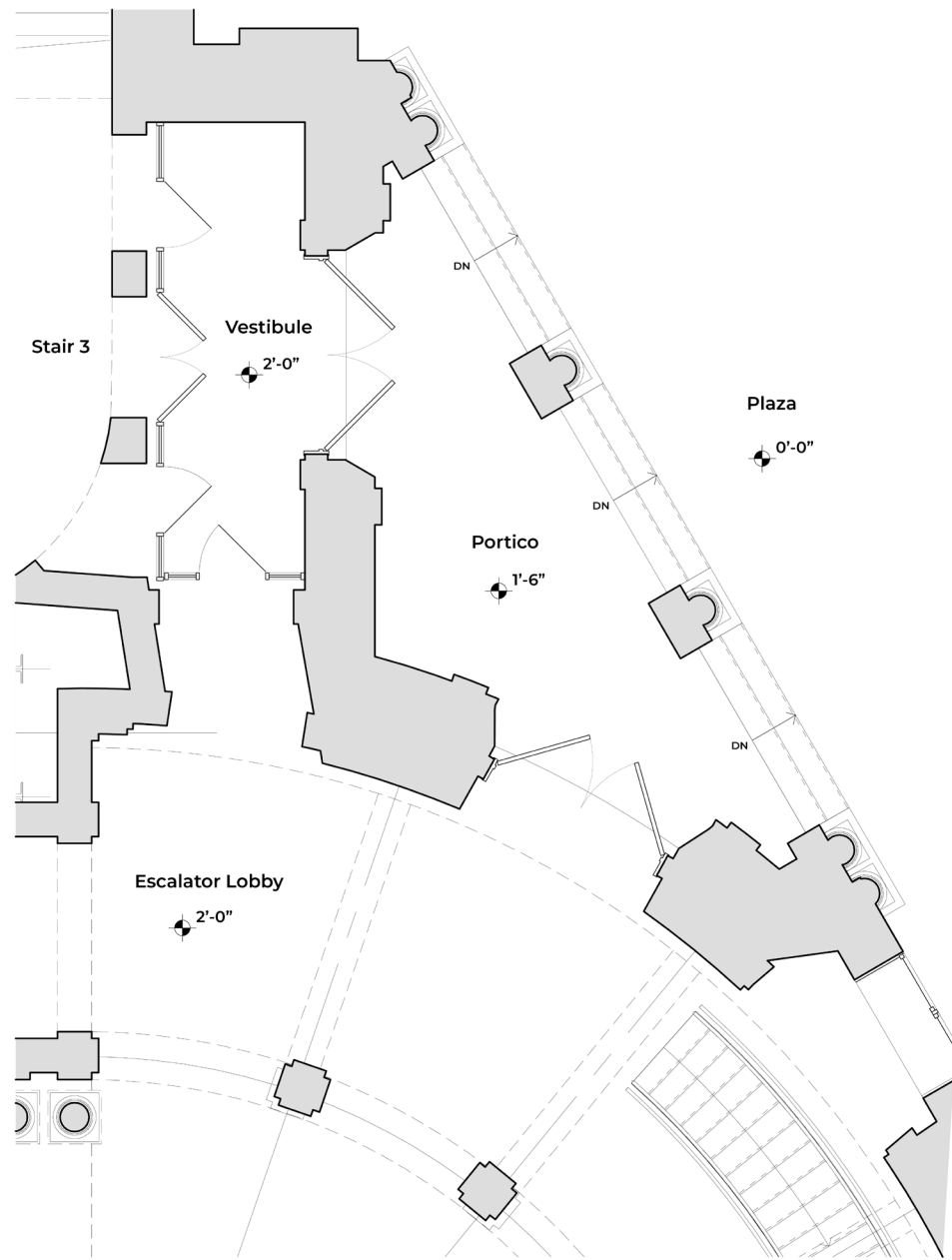

Plan - Existing

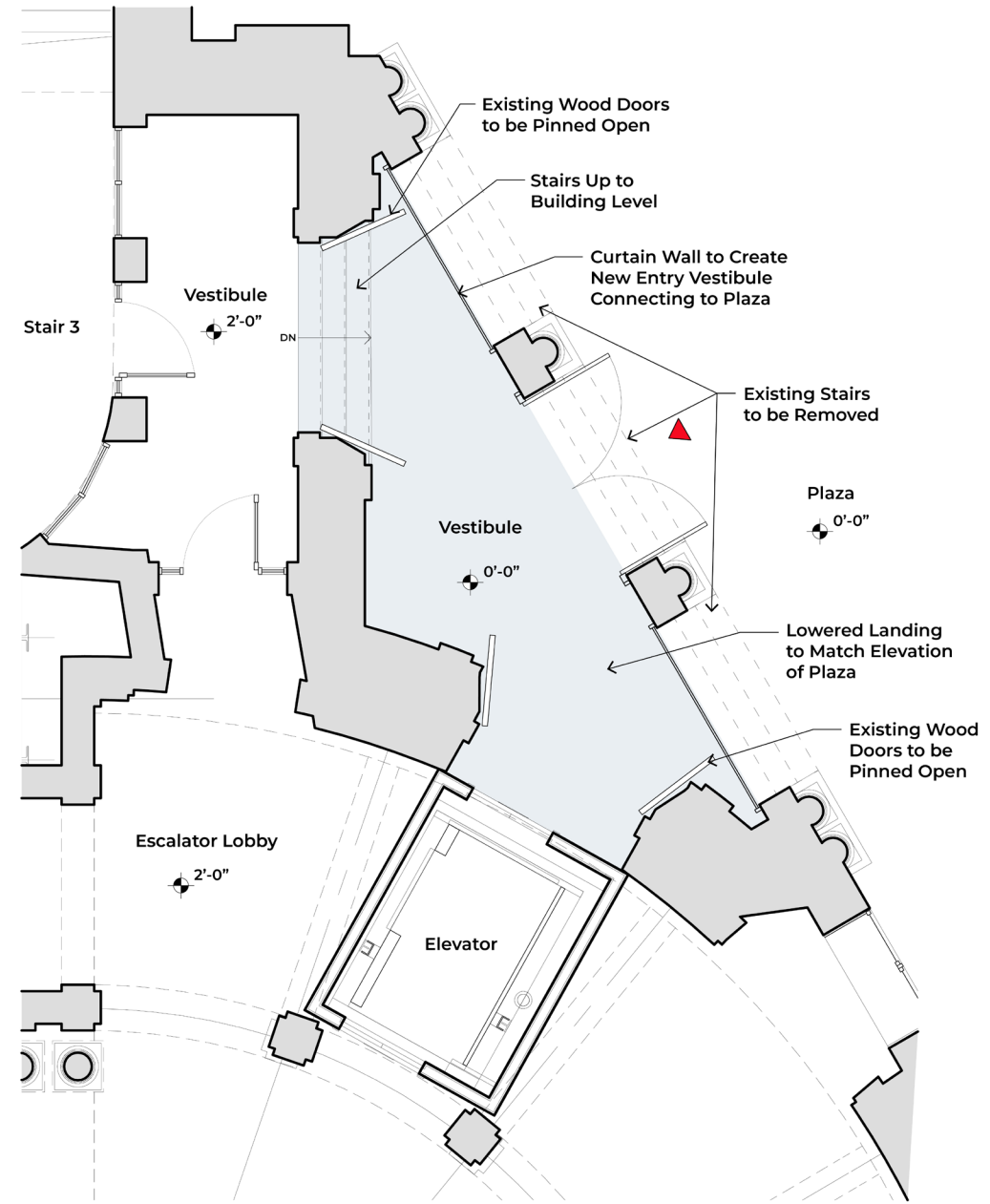

Plan - Proposed

# Original Design Concept



**3D Conceptual View – Existing**



**3D Conceptual View – Proposed**

# Original Design Concept

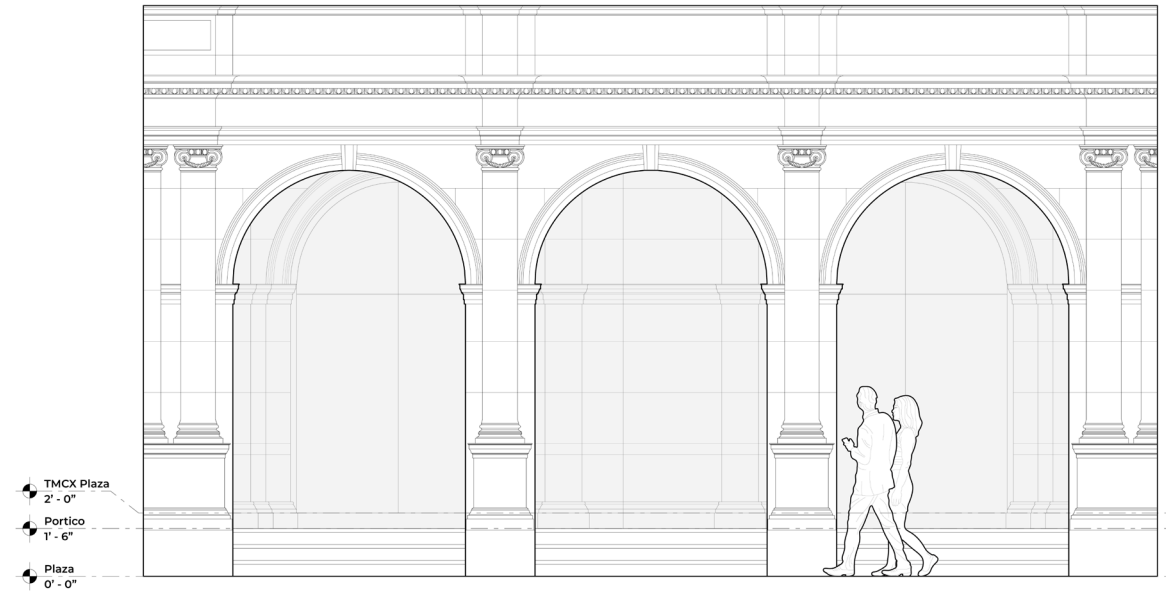

**Exterior Elevation – Existing**



**Exterior Elevation – Proposed**

Frame Mounted ADA Push Button Operator  
Bronze Double Doors

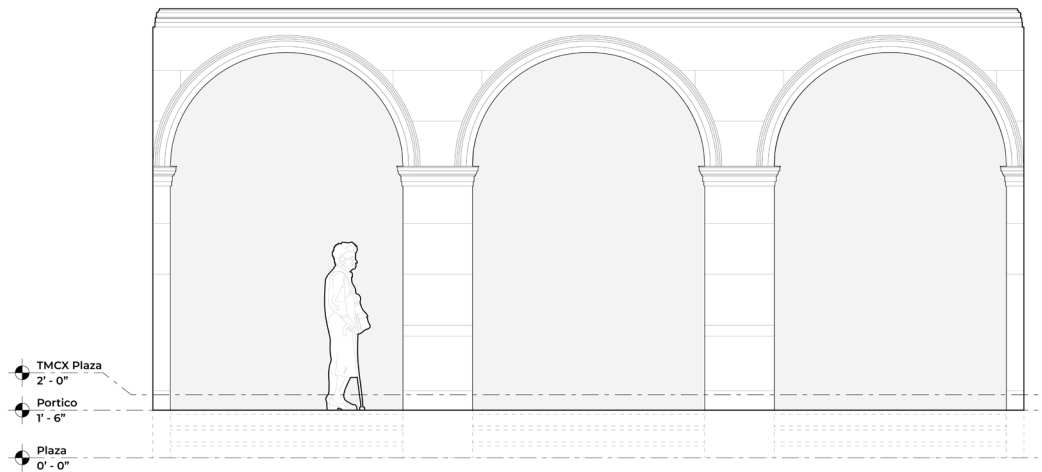

**Interior Elevation – Existing**

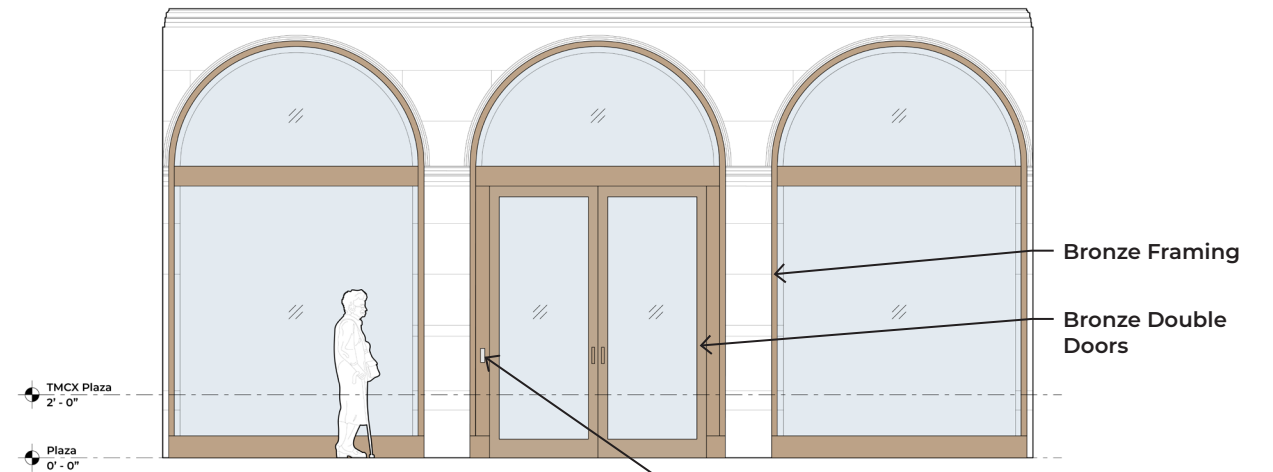

**Interior Elevation – Proposed**

Frame Mounted ADA Push Button Operator

Bronze Framing  
Bronze Double Doors

**Modified Option**

# Modified Option

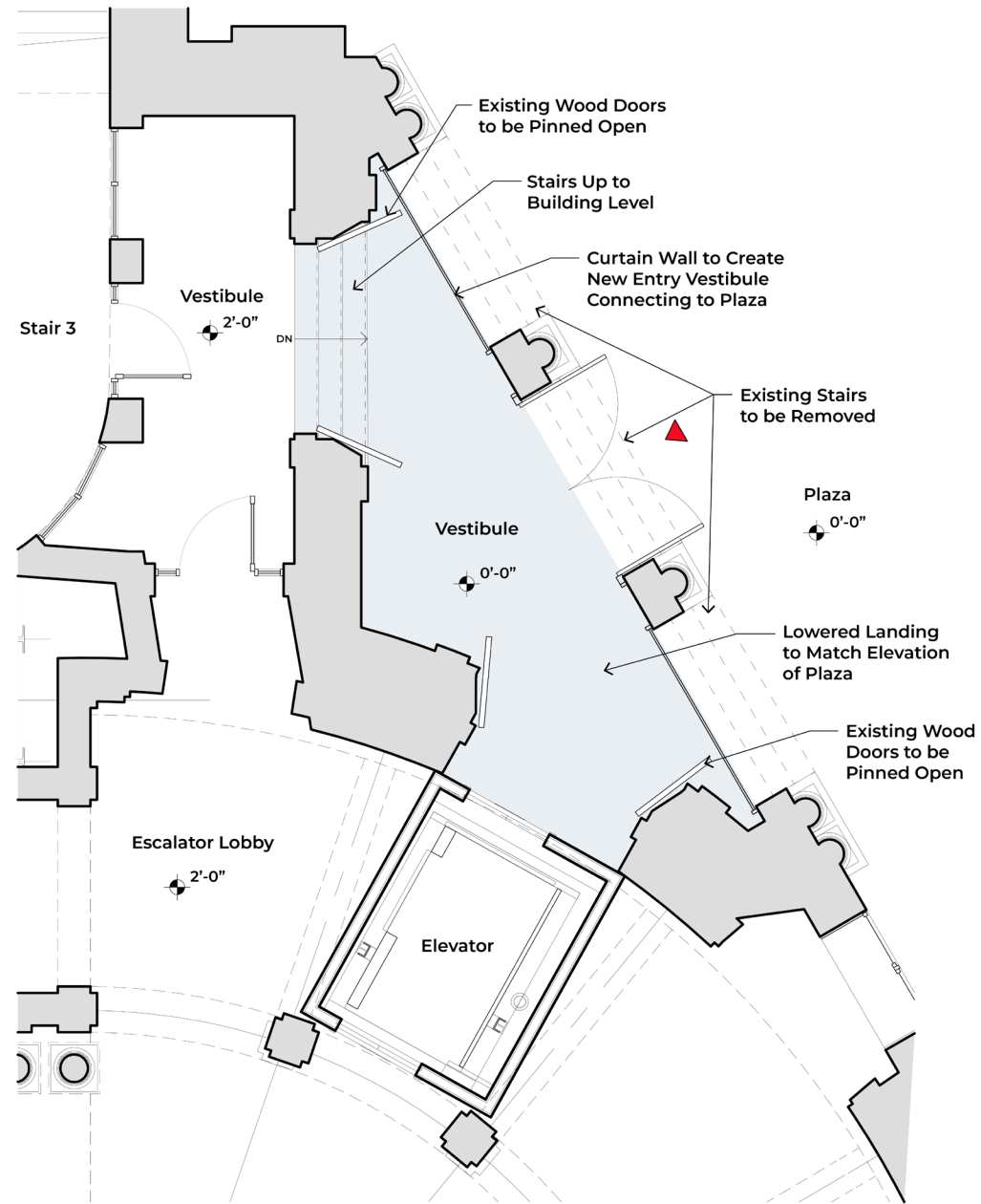

Plan – Original Option

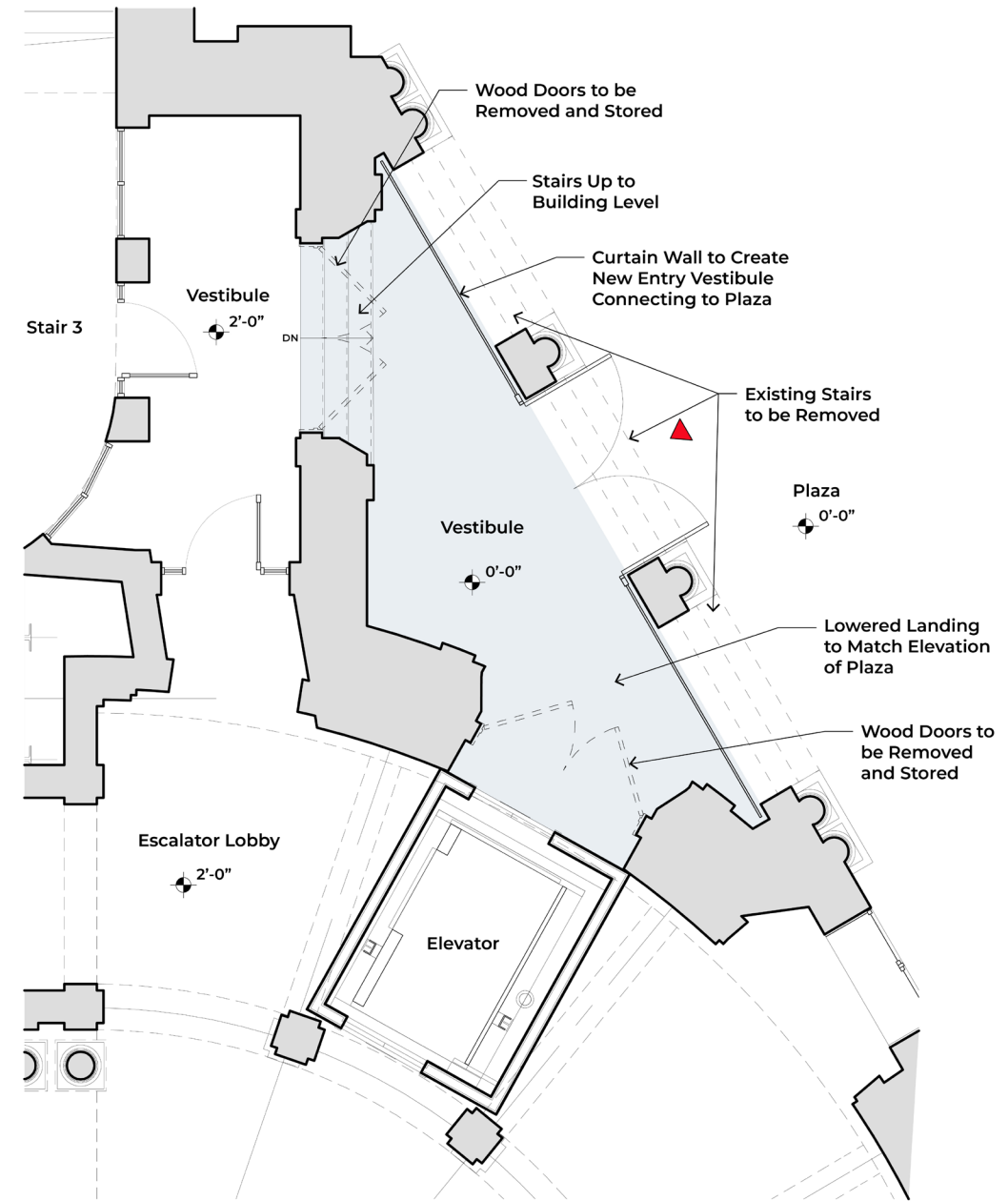

Plan – Modified Option

# Modified Option

## PROS

- + Symmetrical exterior elevation treatment, similar to the Mass Ave portico lobby.
- + Provides a weather controlled accessible entry from the plaza.
- + Allows for 24/7 accessible access to both the plaza and garage.
- + Creates a safe and inviting public entry for visitors and congregants to both TMCO and TMCX.
- + Minimal attachment points for new glass storefront to back side of arched openings.
- + New interventions are reversible.

## CONS

- Two sets of existing wood doors would need to be removed and stored.
- Introduces new material (glass) to the architectural vocabulary of this area of the church.
- Lowers portico/vestibule floor and requires new stone veneer to match existing facade.

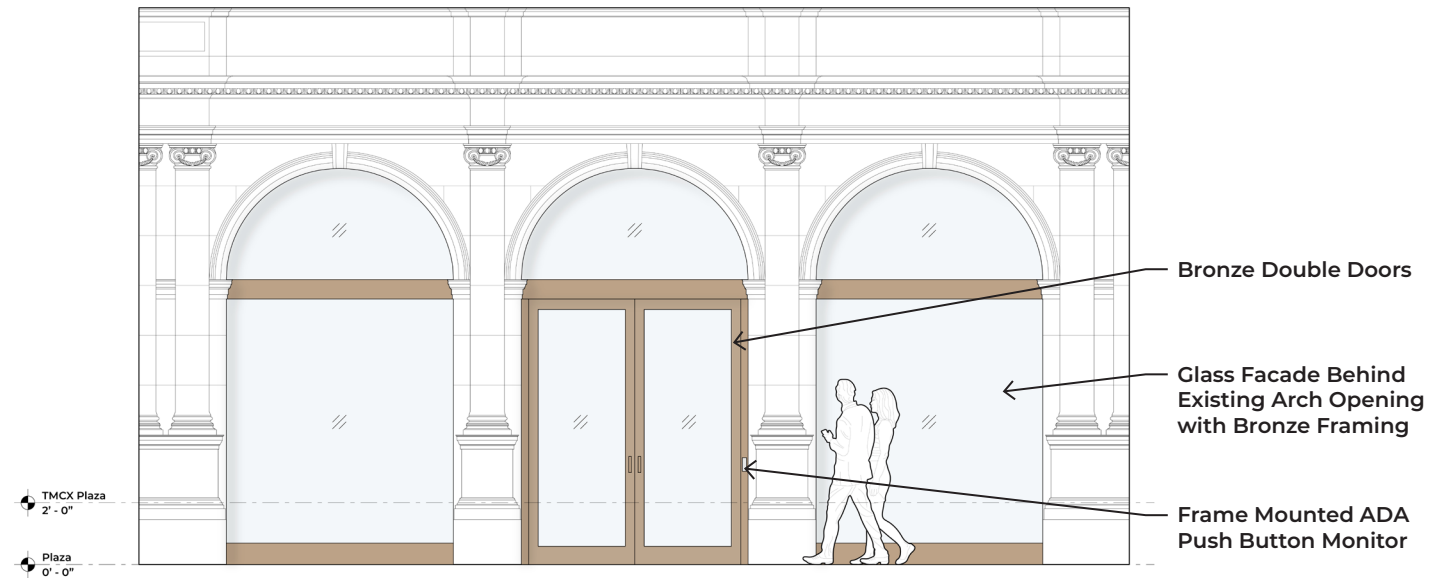

**Exterior Elevation – Original Option**

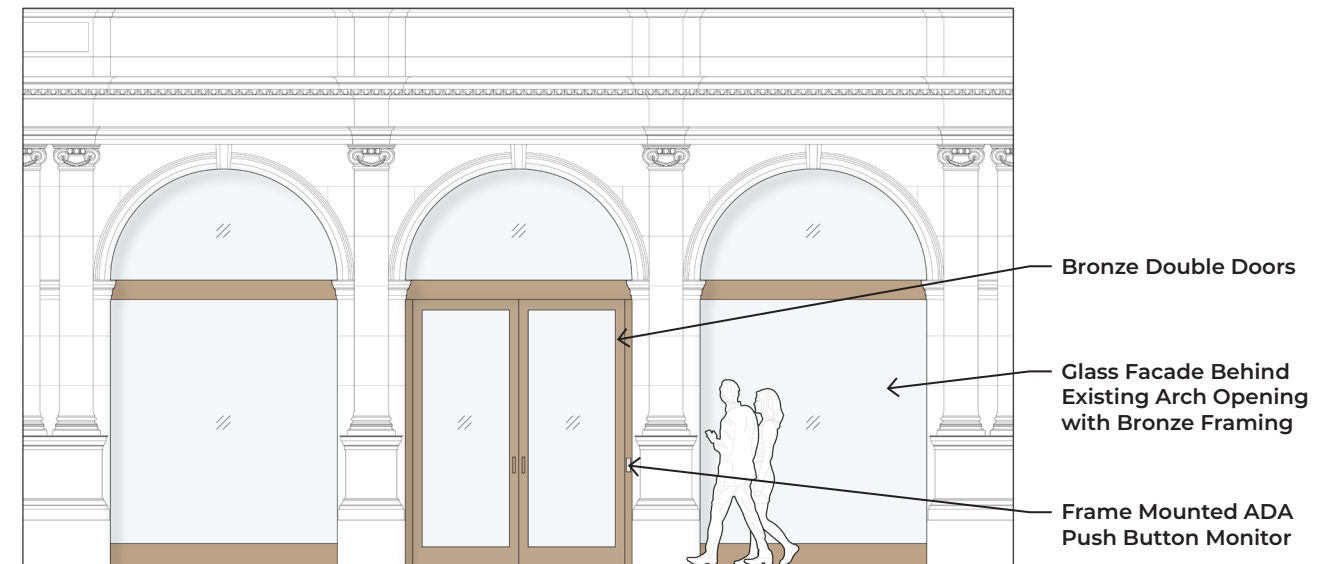

**Exterior Elevation – Modified Option**

# Modified Option

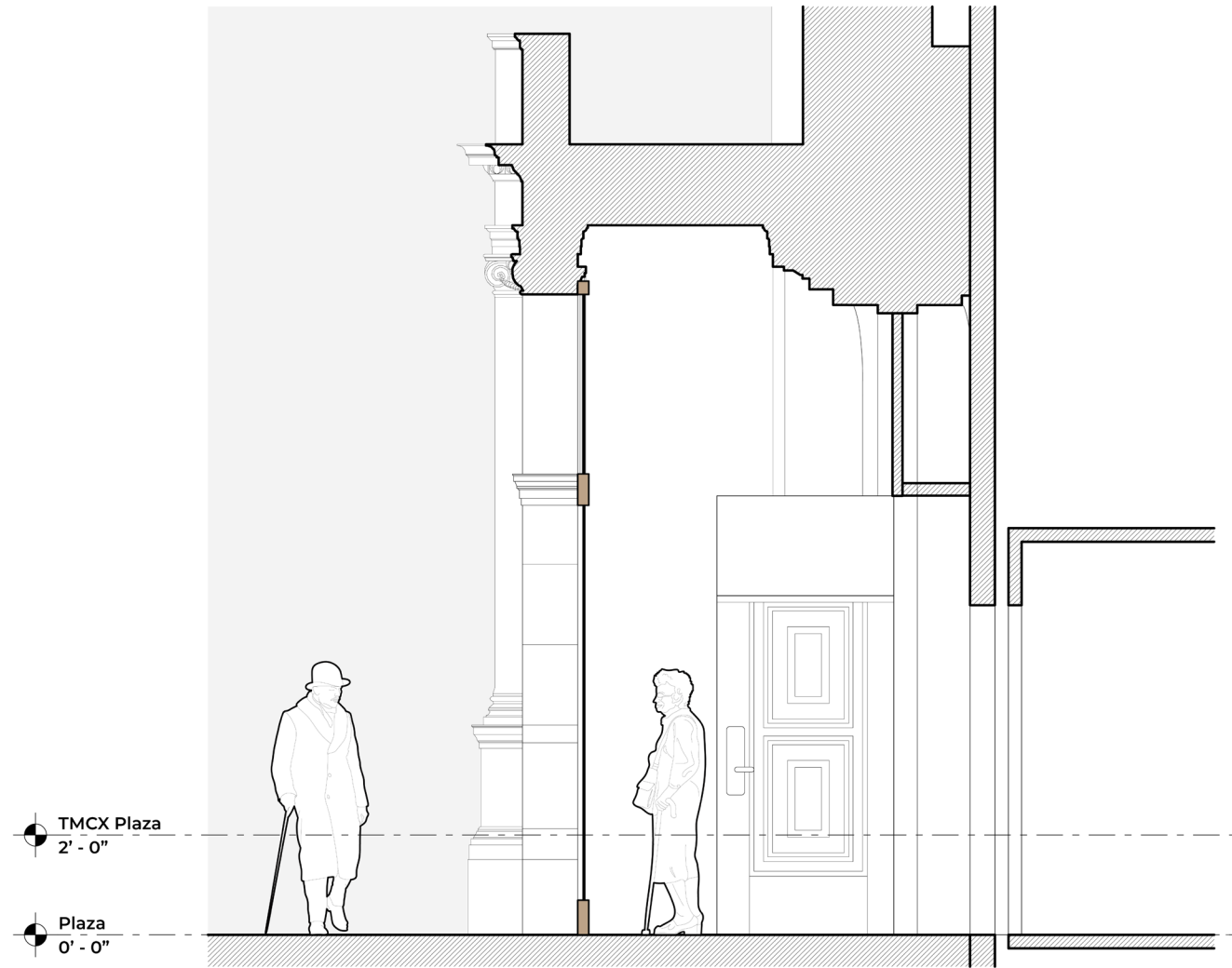

Section at Vestibule and New Elevator – Original Option

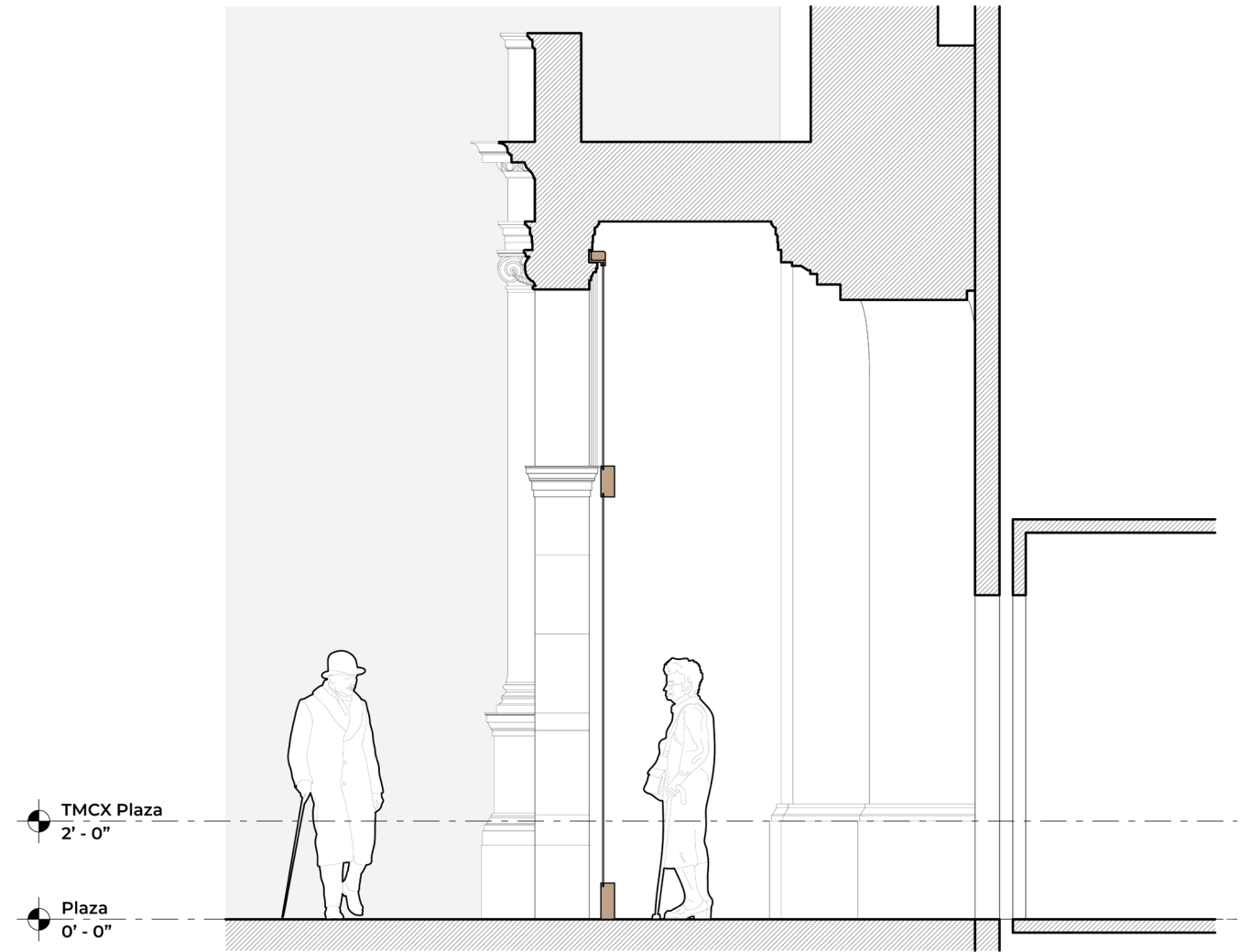

Section at Vestibule and New Elevator – Modified Option

# Modified Option

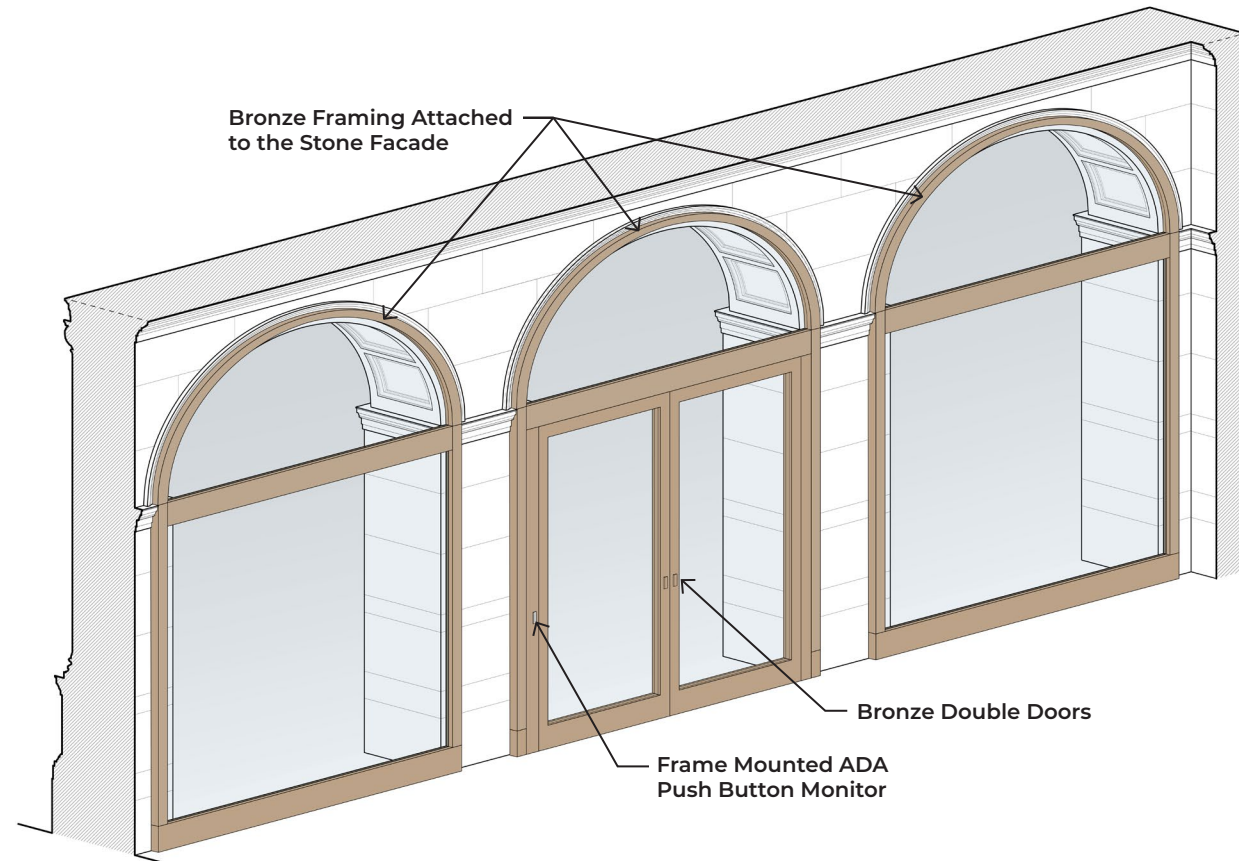

Interior Isometric – Original Option

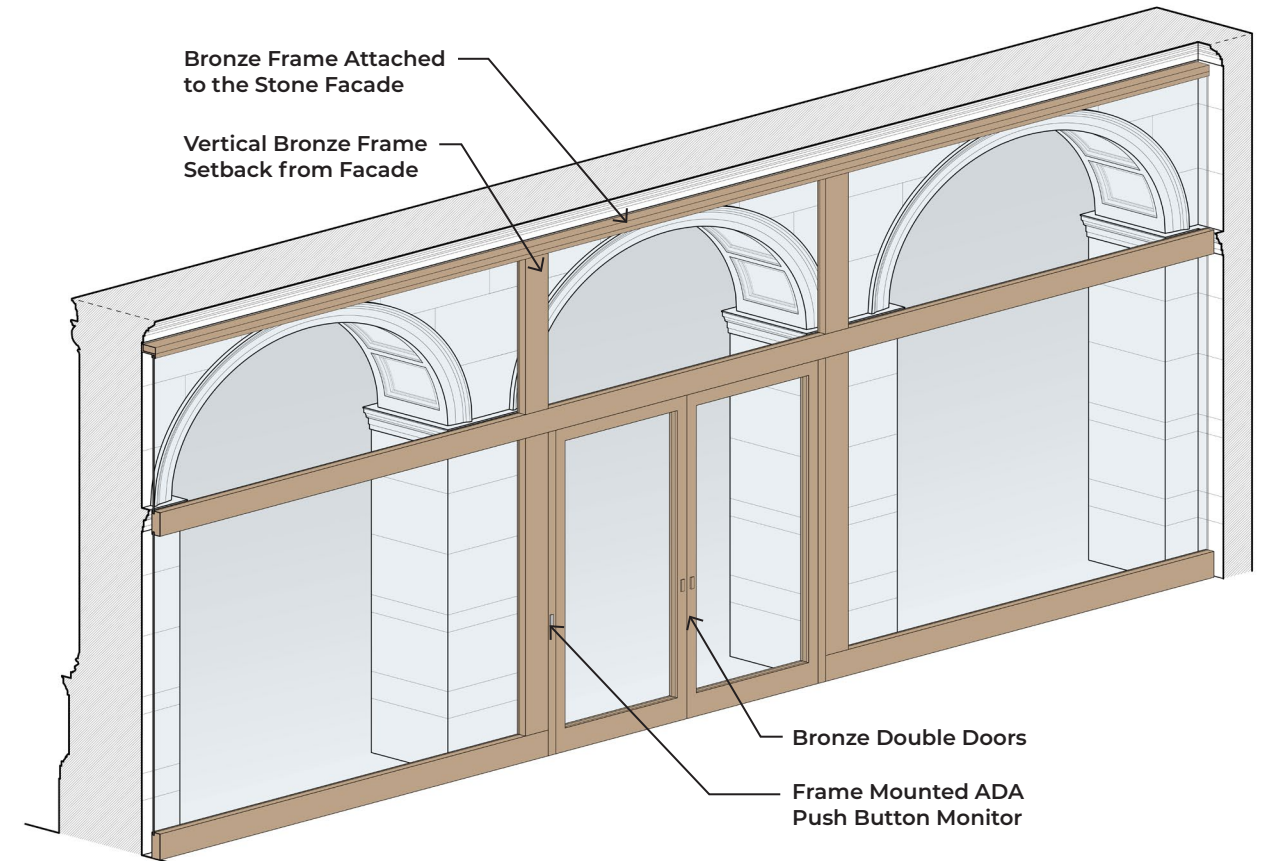

Interior Isometric – Modified Option



# Modified Option

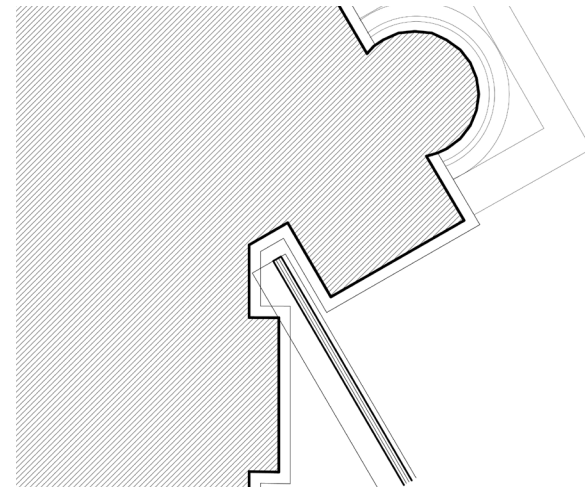
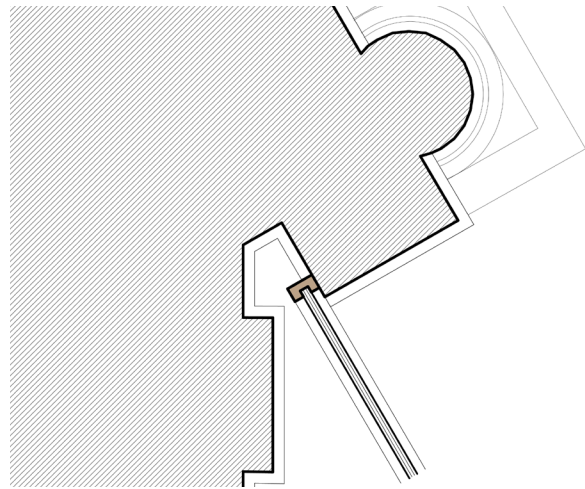

**Original Option**

**Modified Option**

**Plan Detail at Pinchpoint**

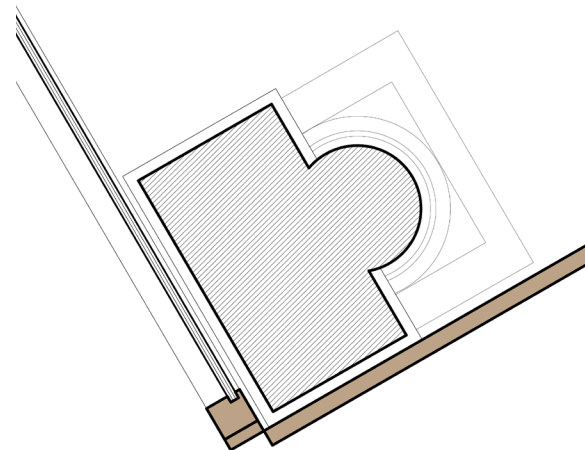
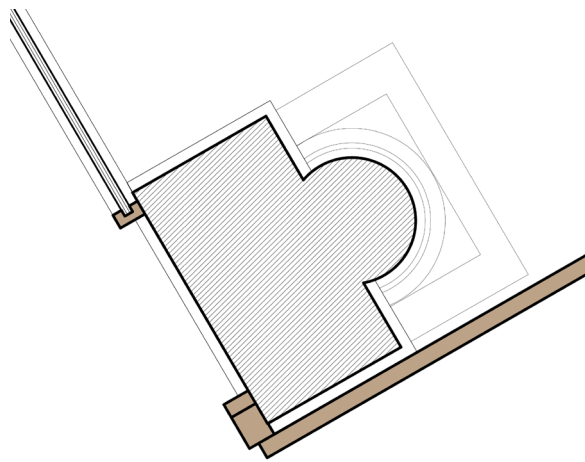

**Original Option**

**Modified Option**

**Plan Detail at Pier**

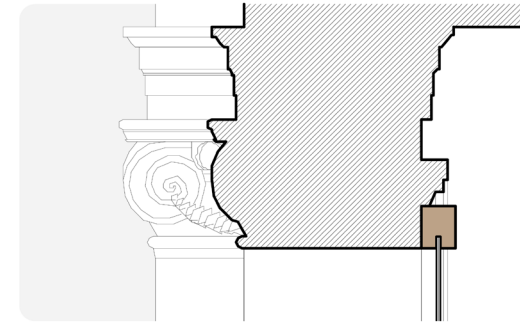

**Head Detail**

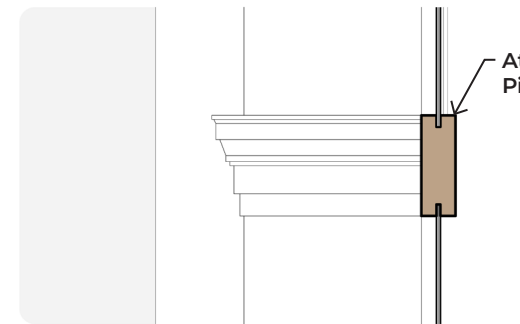
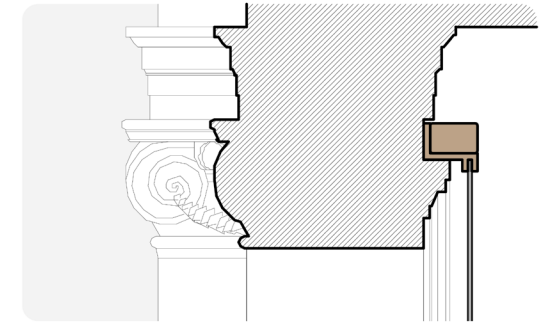

Attached to Pier

**Transom Detail**

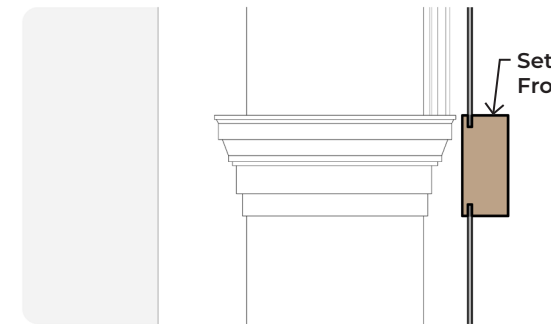

Setback From Pier

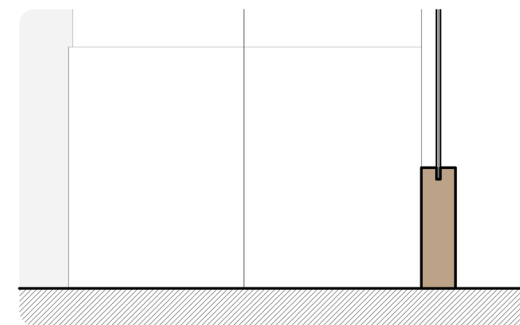

**Base Detail**

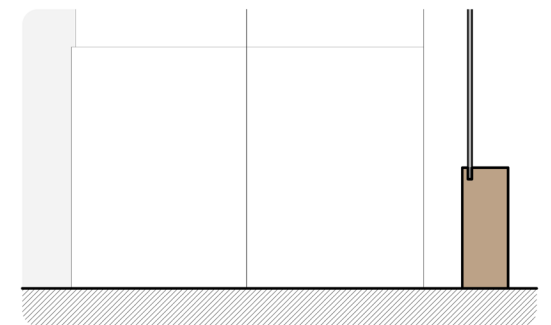

**Original Option**

**Modified Option**

**Glazing and Frame Attachments to Existing Pier**

# BLC Suggestions

# BLC Suggestions

**1 Lower Entire Portico:**  
Lowering the portico and placing stairs directly adjacent to the egress doors without a landing is not code compliant.

**2 Add Doors in Front of Elevator:**  
Doors located at an accessible entrance must comply with code and be located 48" min from the elevator doors. Given the geometry of the portico, this is not feasible.

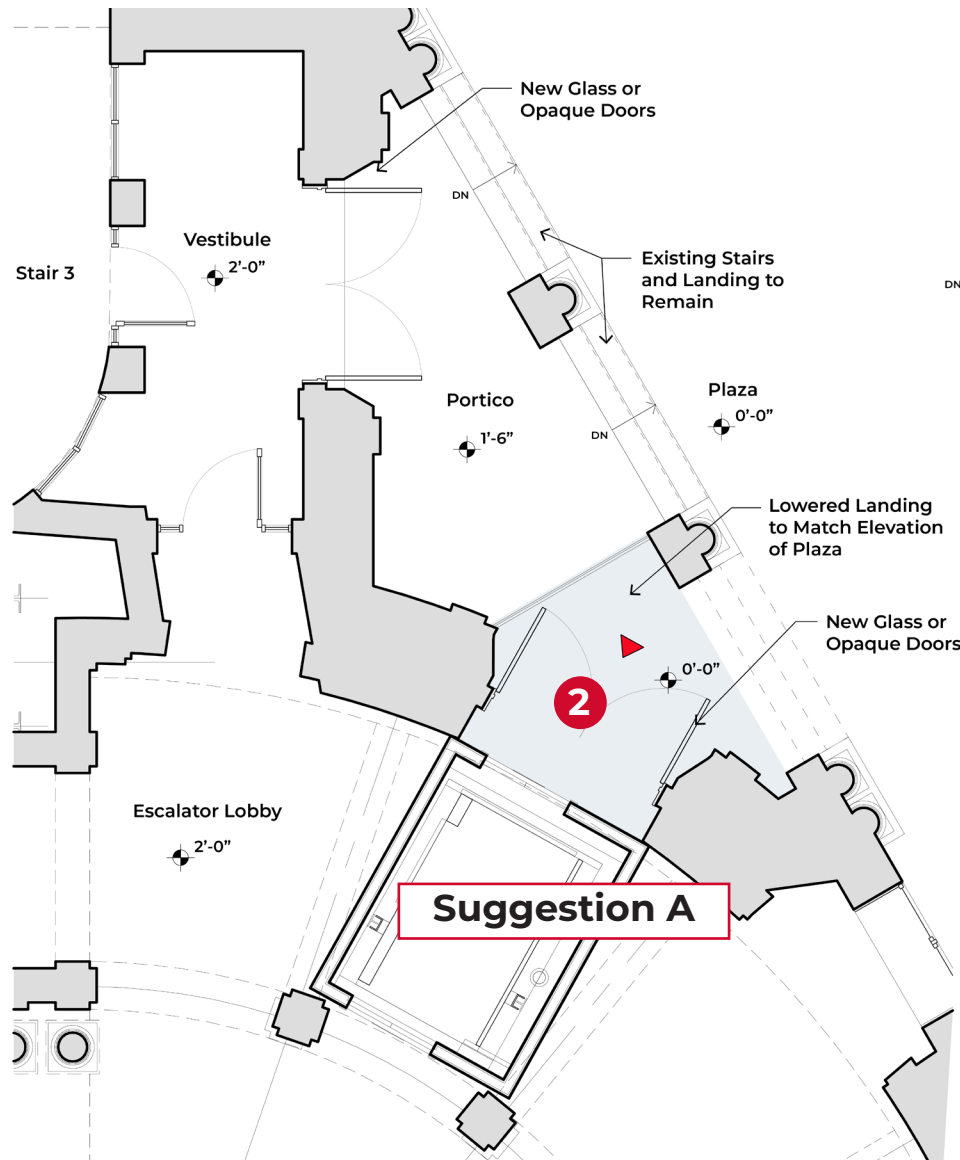

**Suggestion A**

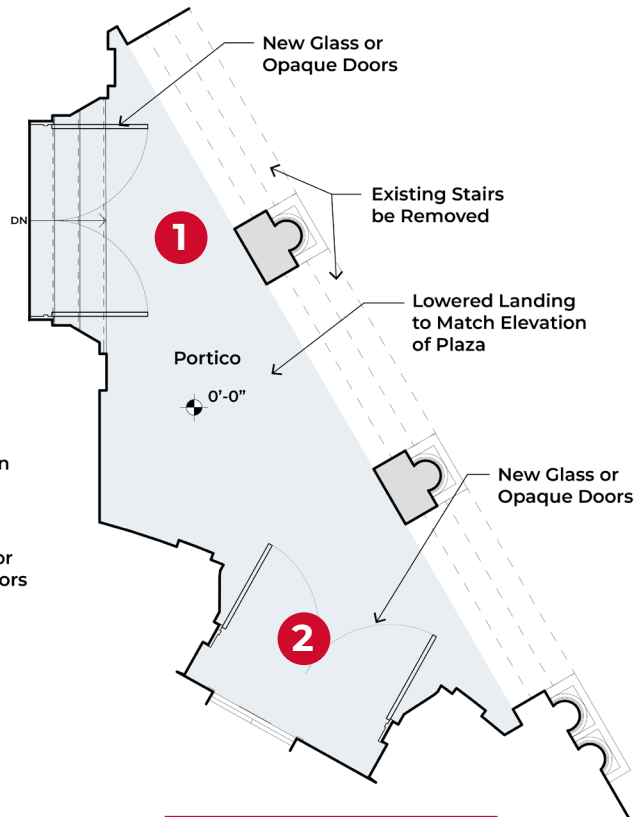

**Suggestion B**

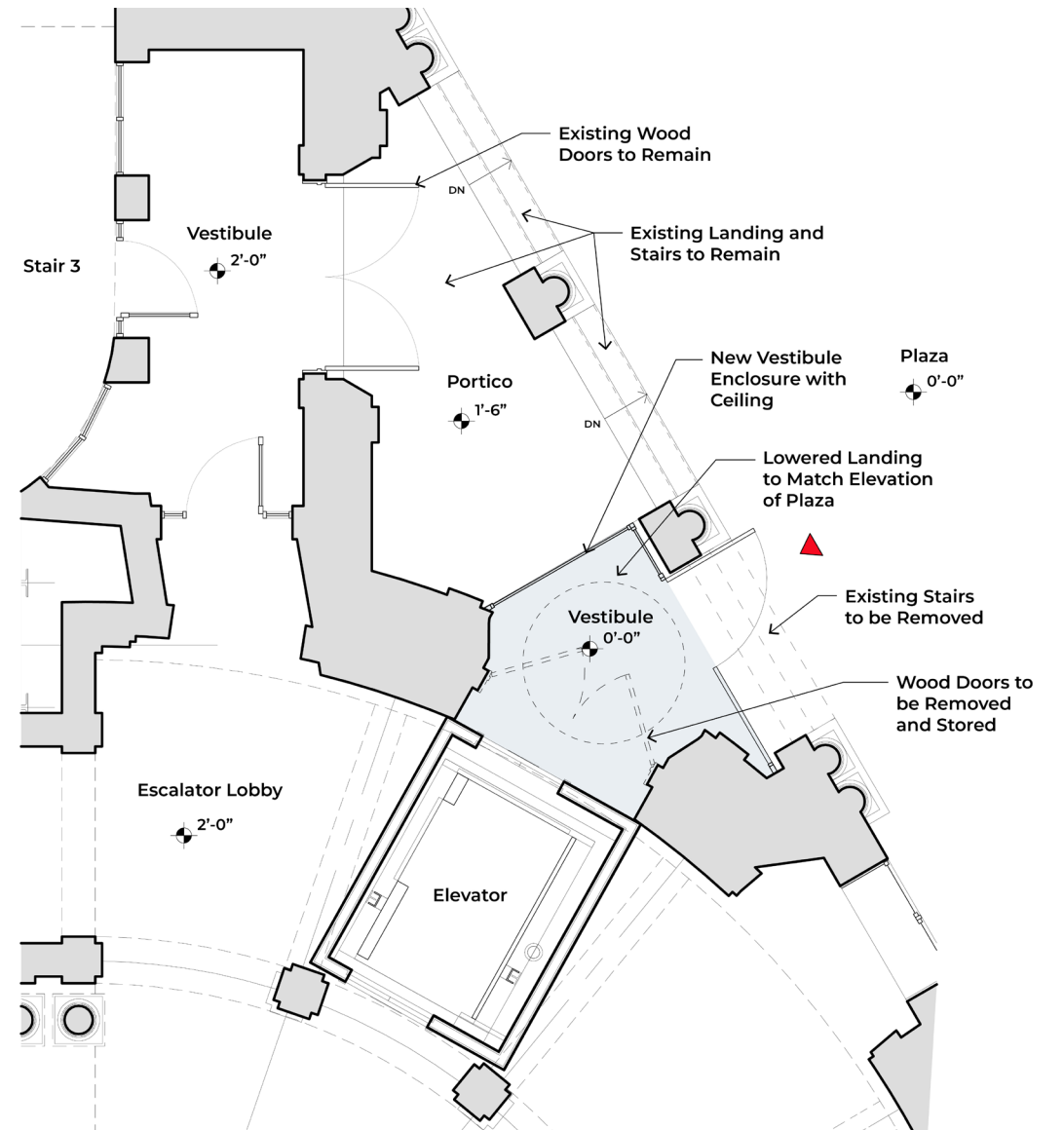

**Required Adjustments to Make BLC Suggestions Feasible**

# BLC Suggestions with Required Adjustments

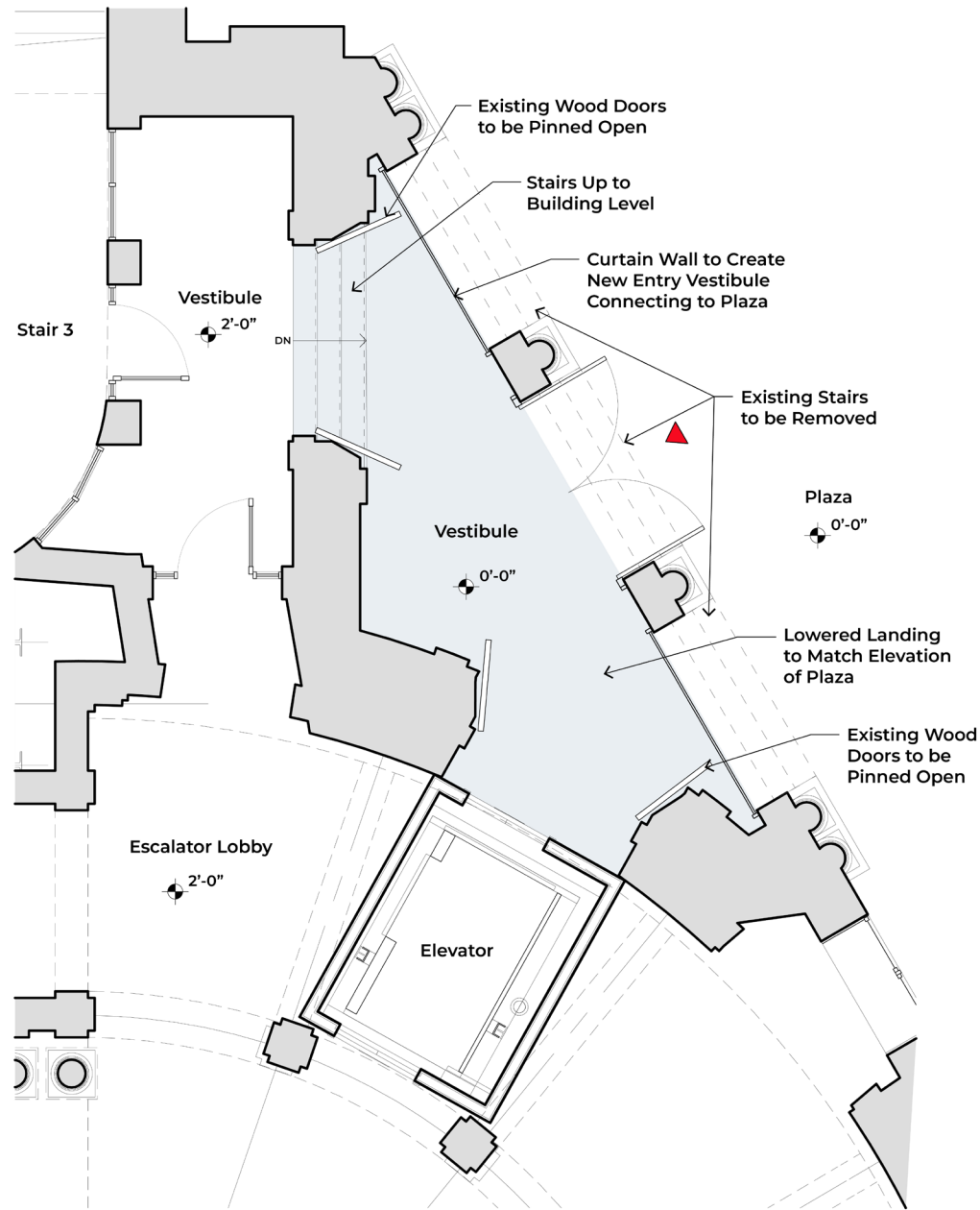

Plan - Original Option

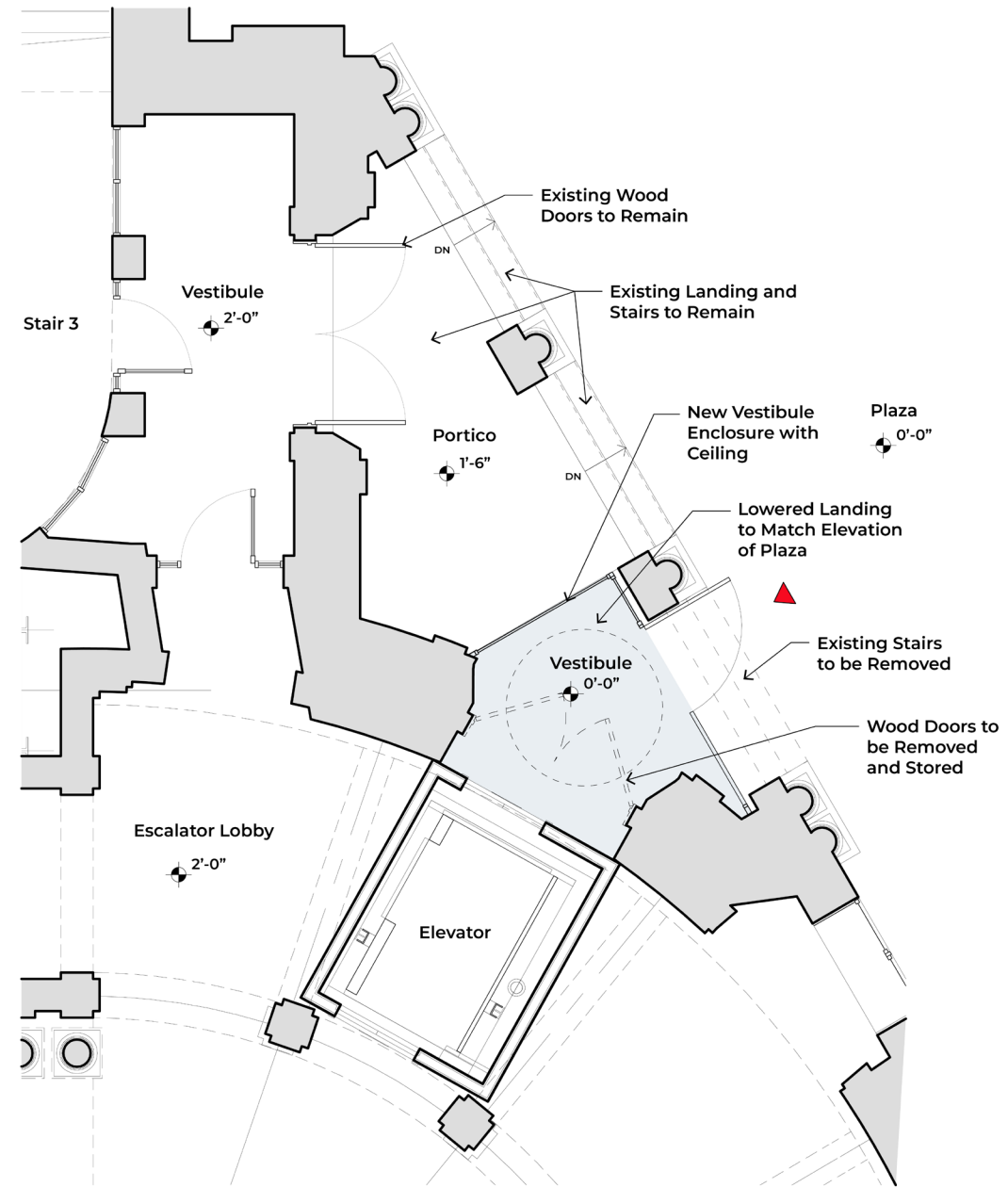

Required Adjustments to Make BLC Suggestions Feasible

# BLC Suggestions with Required Adjustments

## PROS

- + (Suggestion A) Provides a symmetrical design solution for this portico.
- + (Suggestions A & B) Does not include new material (glass) to the architectural vocabulary of this area of the church.

## CONS

- Lowering the portico and placing stairs directly adjacent to the egress doors without a landing is not code compliant.
- Suggested glass doors just in front of elevator doors do not provide required clearances and is not code compliant.
- Exterior exposed elevator is not recommended by elevator expert consultant.
- New vestibule would require permanent alterations to the existing stone facade detail.

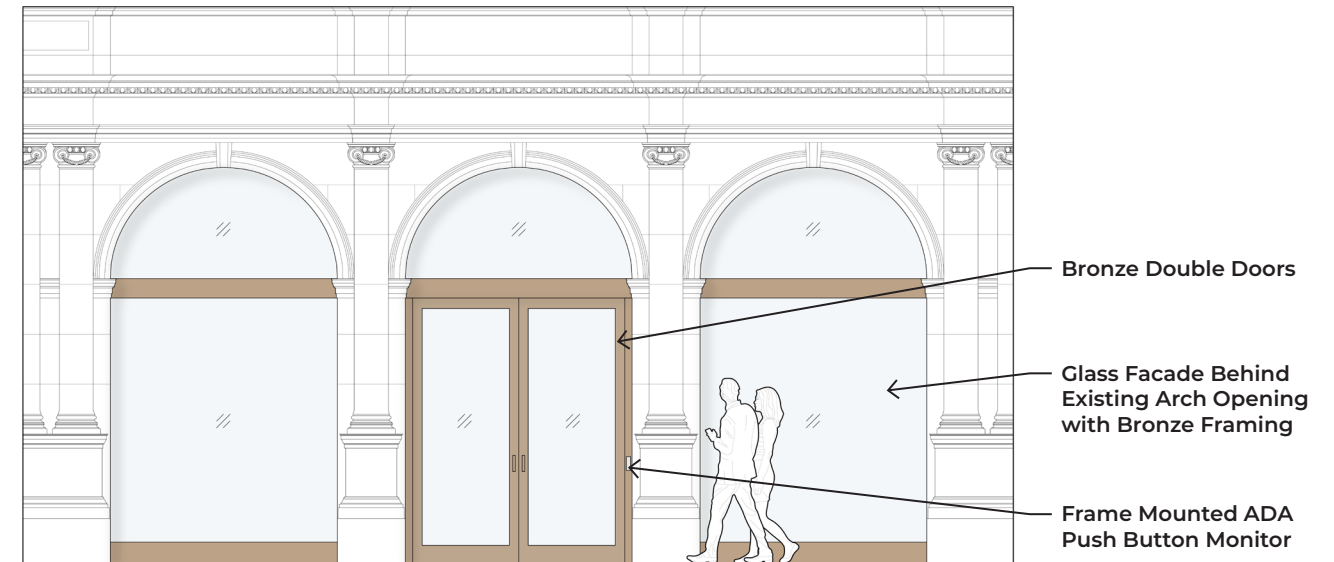

**Exterior Elevation – Original Option**

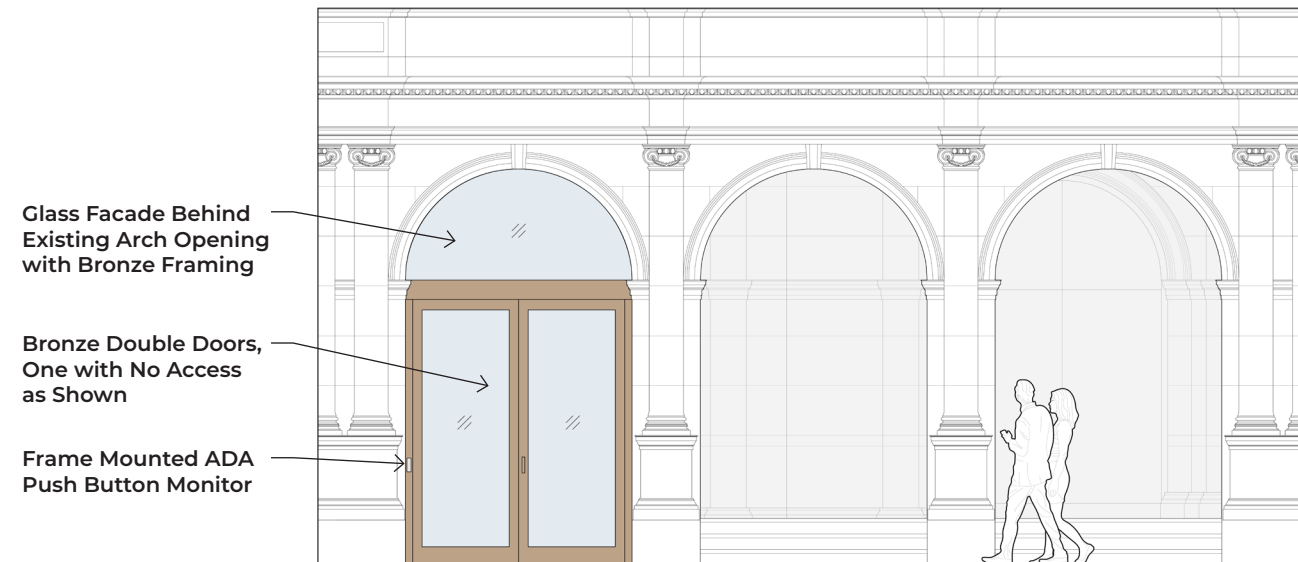

**Exterior Elevation – Required Adjustments**

# BLC Suggestions with Required Adjustments

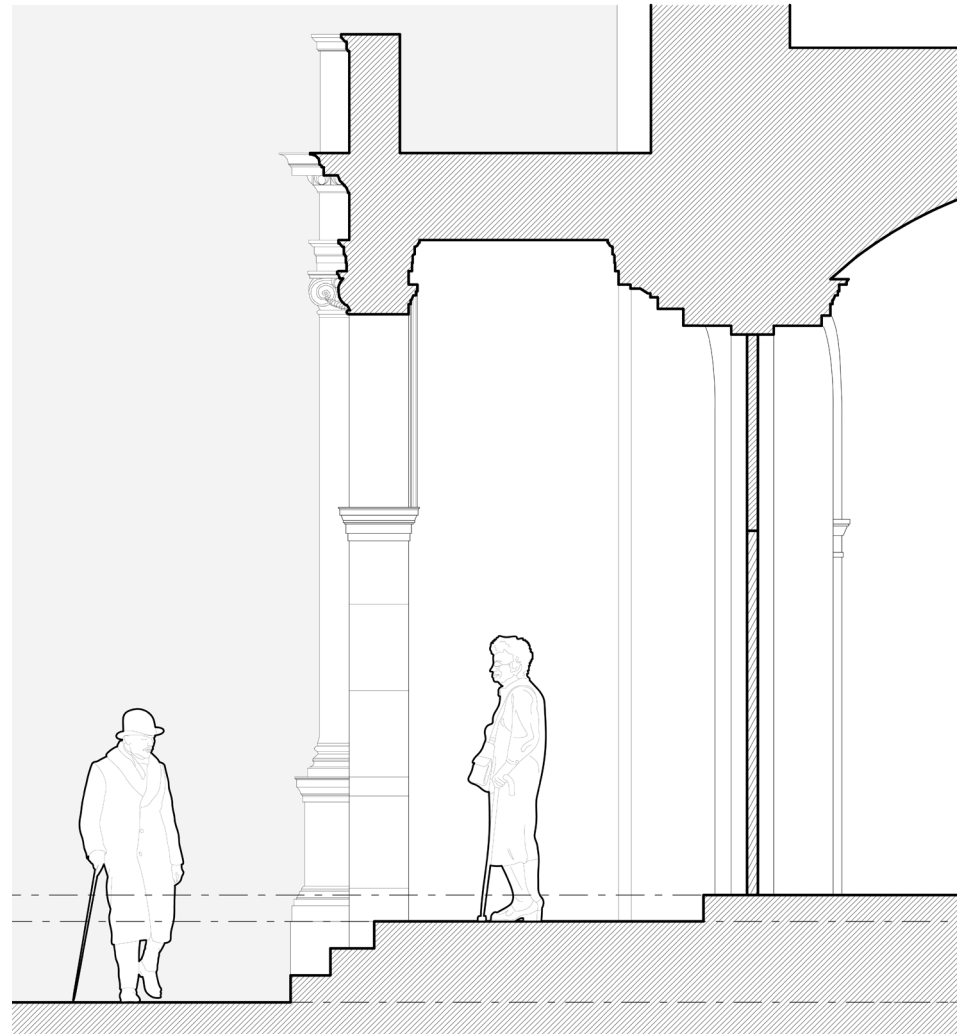

Section at Portico and Interior Vestibule

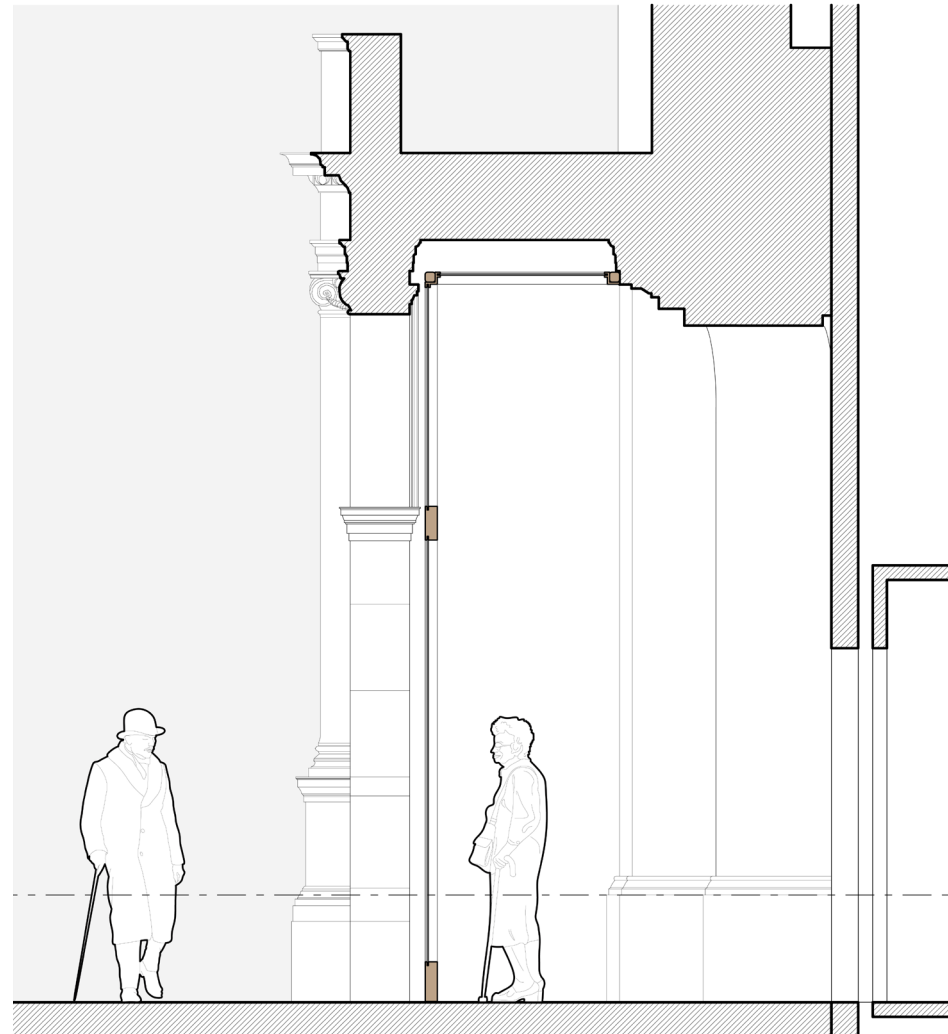

Section at Vestibule and New Elevator

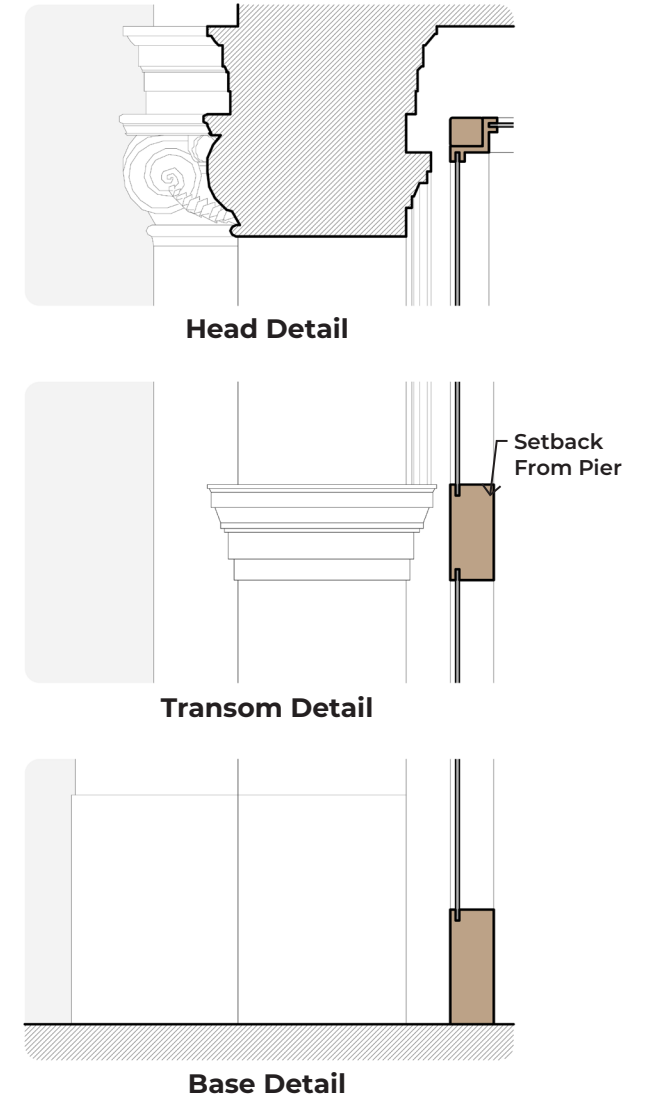

Enlarged Sections at Pier

# BLC Suggestions with Required Adjustments

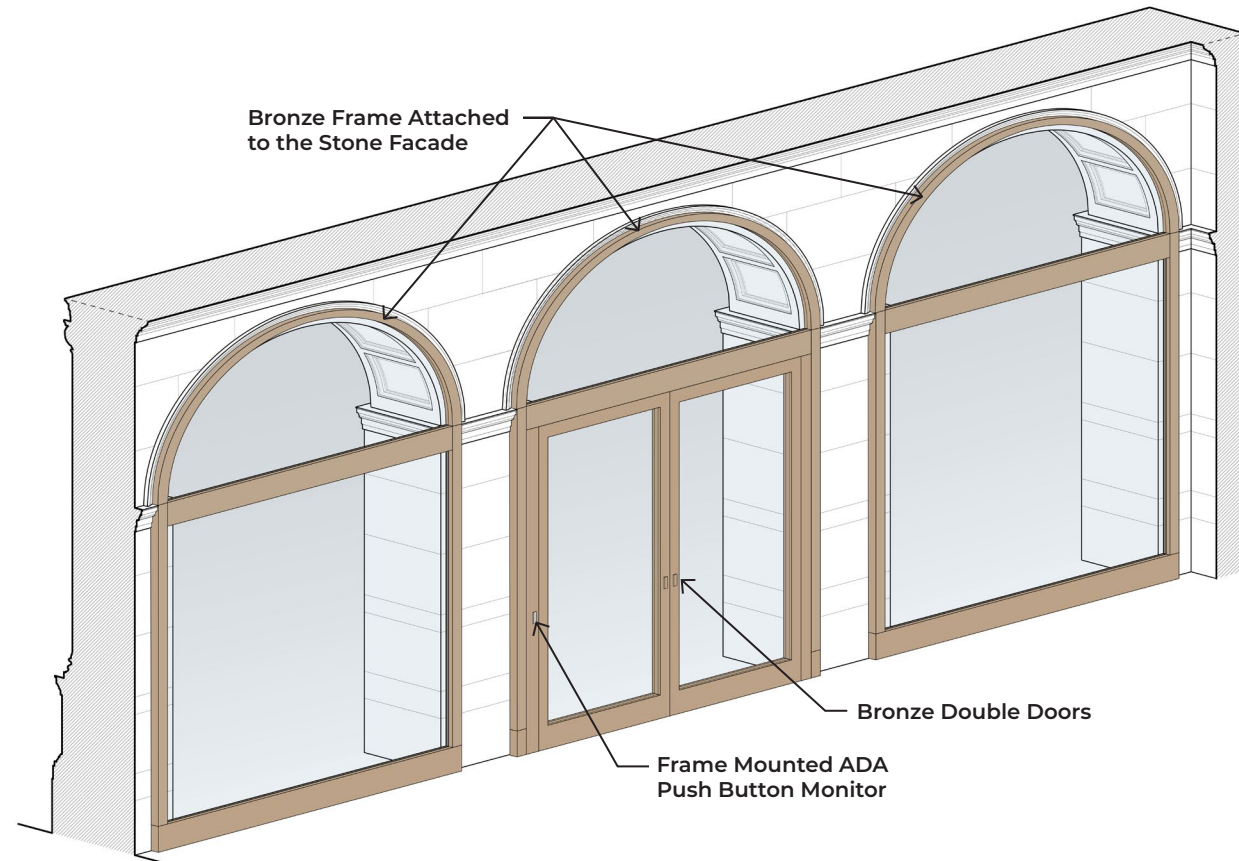

Interior Isometric – Original Option

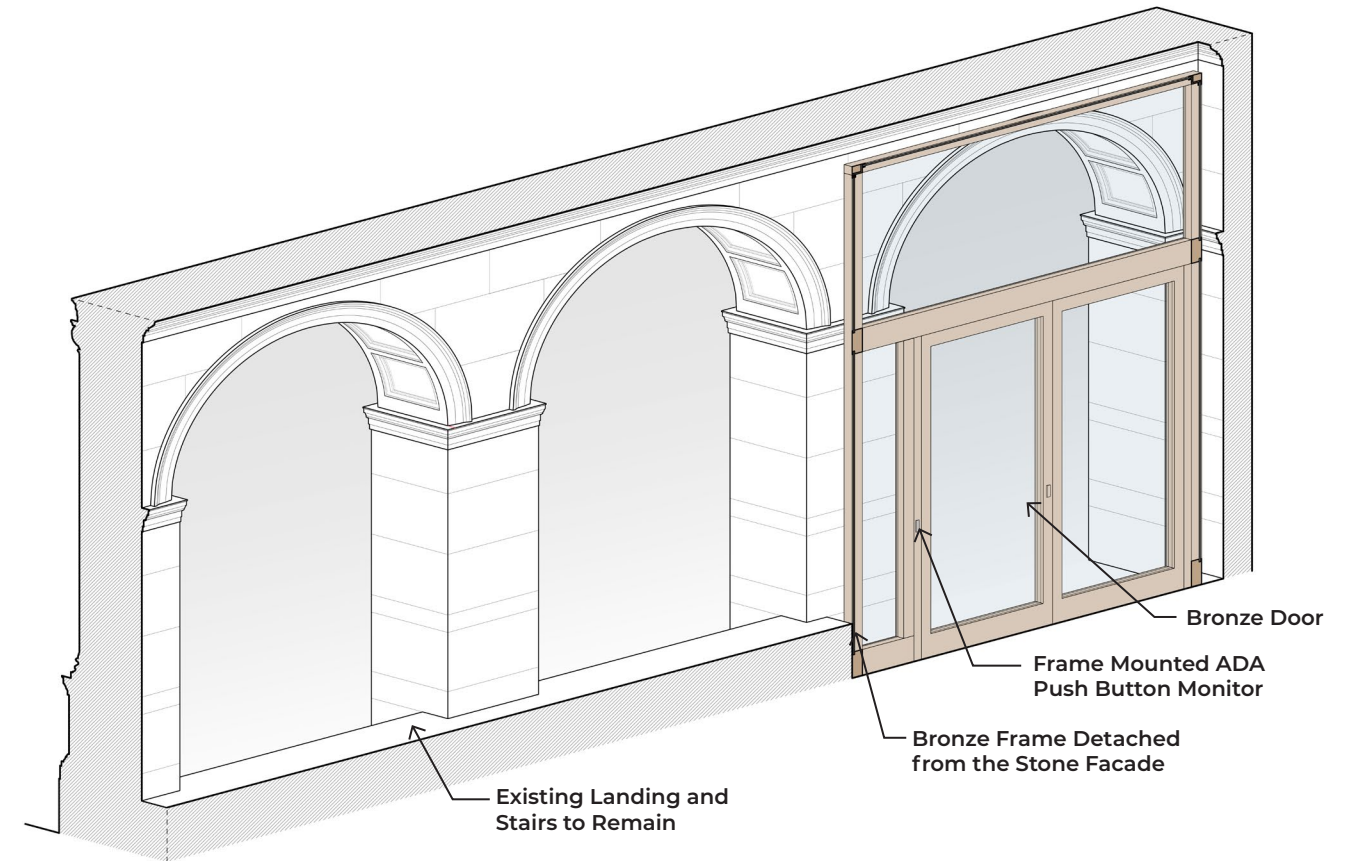

Interior Isometric – Required Adjustments

# BLC Suggestions with Required Adjustments

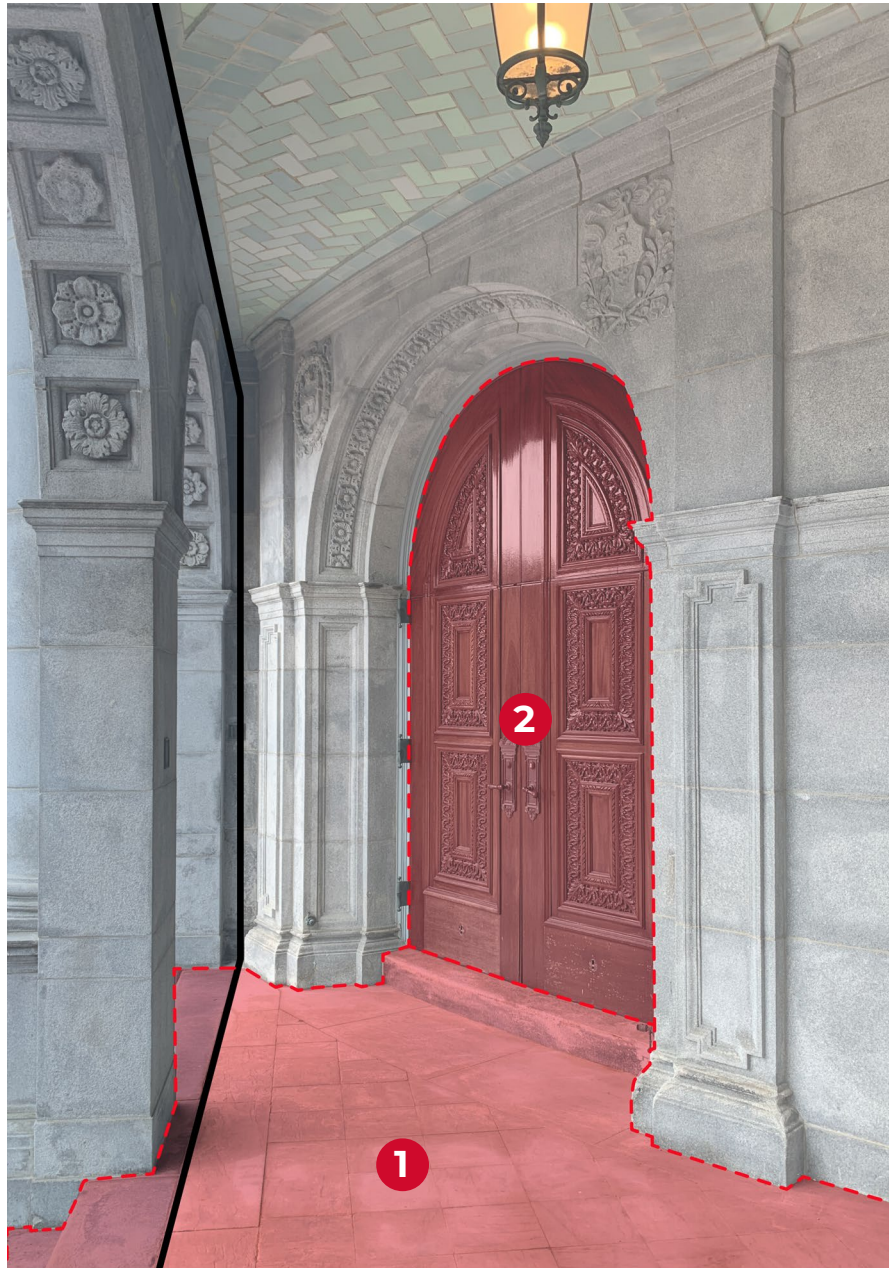

Frame Attachments to Existing Stone  
Modified Option

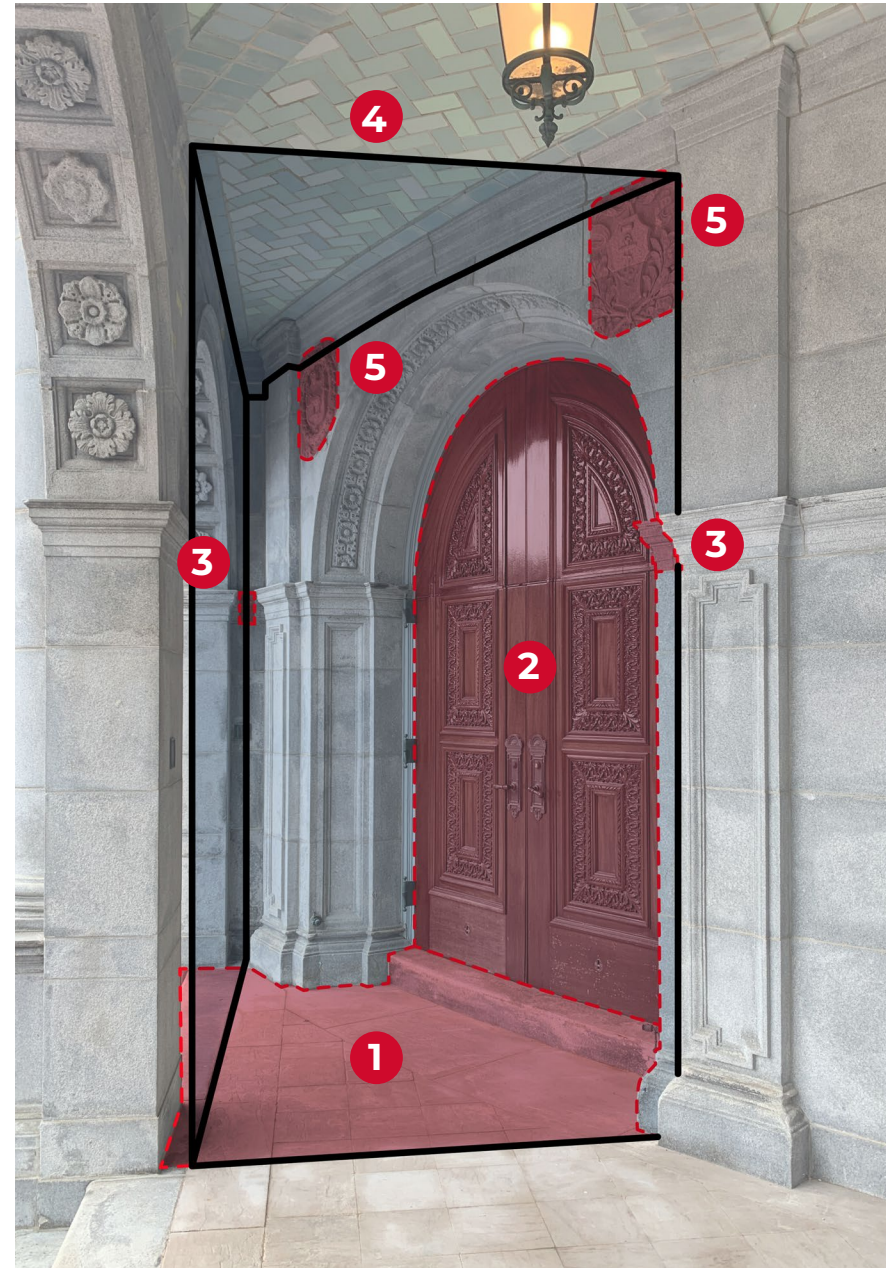

Frame Attachments to Existing Stone  
Required Adjustments

- 1 Portico landing to be lowered to match the elevation of the plaza.
- 2 Existing wood doors to be removed and stored.
- 3 Section of capital would need to be removed for vestibule attachment.
- 4 Arched Guastavino tiled ceiling to remain as existing.
- 5 Medallions carved into the stone would need to be removed.



# Exterior-Grade Elevator Examples

Elevator at MBTA's Ruggles Station



# Memo from Elevator Manufacturer



## FIRST CHURCH CHRIST SCIENTIST Elevator Vestibule Memo

Lerch Bates has been asked to write a memo describing the condition that will be occurring with the new elevator that is to be installed at First Church Christ Scientist, where the unit will be opening to the outside. This memo shall describe how these conditions can adversely affect the elevator.

With vast experience working with elevators that open to the elements, specifically auditing each piece of equipment that is owned by the MBTA this past year, we can safely provide real world descriptions of how the elements can challenge the day-to-day operation of elevators. Any time an elevator opens to the outside; moisture from humidity, rain and snow will get into the elevator cab and hoistway. This degrades the steel throughout and more importantly the electrical components that run throughout the elevator cab and hoistway. This includes the elevator car operating panel that houses all of the code required buttons and fixture boards, the door operator that is mounted on top of the elevator and the travelling cable that attaches to the bottom of the cab and houses all of the electrical connections for the elevator. Each of these components experience corrosion with the presence of the moisture and will naturally degrade at a faster rate than an elevator enclosed from the elements. Being in New England, we also have the issue of rock salt which is used throughout the winter months. The chemicals used here to melt ice get blown in the elevator sills, into the hoistway and brought into the elevator cab on patron's shoes. The ice melt then deteriorates the sills, bottom of the entrance assembly and the cab flooring which requires future repairs and can even lead to patron entrapments. We find that most entrapments occur from door related issues. If rocks or ice melt gets trapped in the elevator sills, then the doors can get caught and cause the elevator to shut down. The door operator is also overly taxed when trying to push through debris which can cause the door operator motor to fail prematurely and require repair.

So far, we have gone over all of the different elevator components that will have shortened life cycles due to exposure to the elements. Now I would like to discuss the increased maintenance costs and initial installation costs that occur when installing an elevator without a vestibule or other protection. We mentioned the MBTA earlier since they have several elevators that open to the sidewalk or other outdoor conditions. The MBTA pays an excessive amount of money to have mechanics onsite 7 days a week to continually perform maintenance and repairs to keep their equipment in operation. Even with this massive cost, they still have daily shutdowns at stations throughout the city and surrounding communities that require repairs. These repairs happen most frequently on the elevators and escalators that open to the elements. Water is most definitely an enemy of vertical transportation equipment. These MBTA units also install more robust equipment in order for them to run in an exterior environment. We specify for them NEMA rated door operators and car top equipment that is encased in stainless steel boxes with rubber gaskets to protect the microprocessor boards, motors and operator wiring. We cannot enclose the door operator actuating system those which attaches a swing arm to the door assemblies so that chain and swing arm typically rust and degrade which requires early replacement along with continual lubrication to mitigate operation issues. Instead of normal aluminum sills for the elevator, we would specify stainless steel sills which cost 3 times more than aluminum but last 5 times longer when dealing with outside conditions. The hall entrance that is exposed to the outside, along with the cab flooring and cab panels all need to be stainless steel and preferably coated to protect them from corrosion from moisture and winter salt chemicals. Elevators also experience operational issues when exposed to exterior temperatures. Elevator manufacturers require that their equipment operate between 50-90 degrees for proper longevity and to mitigate shutdowns. The current elevator industry shutdown rate is 4 times per year per elevator. Elevators that are exposed to the elements far surpass this metric, the units at the MBTA that experience these conditions experience shutdowns every few weeks which equates to over 12 shutdowns per exterior elevator. This occurs despite their high maintenance costs and vigilant onsite mechanic work. All new station designs require vestibule enclosures for their equipment to protect it from future harm.

Please let us know if you have any further questions, we are happy to go over the elevator equipment as it related to outside conditions. Ultimately, as elevator experts working around the world, we advise our clients against installing exterior opening elevators without a vestibule enclosure for the reasons outlined above.

Best Regards,

*Sam Laudati*

Sam Laudati

Lerch Bates Regional Consultant

## KEY POINTS

- Any time an elevator opens to the outside; moisture from humidity, rain and snow will get into the elevator cab and hoistway. This degrades the steel throughout and more importantly the electrical components that run throughout the elevator cab and hoistway.
- The hall entrance that is exposed to the outside, along with the cab flooring and cab panels all need to be stainless steel and preferably coated to protect them from corrosion from moisture and winter salt chemicals.
- The current elevator industry shutdown rate is 4 times per year per elevator. Elevators that are exposed to the elements far surpass this metric, the units at the MBTA that experience these conditions experience shutdowns every few weeks which equates to over 12 shutdowns per exterior elevator.
- All new station designs require vestibule enclosures for their equipment to protect it from future harm.
- Ultimately, as elevator experts working around the world, we advise our clients against installing exterior opening elevators without a vestibule enclosure

# Design Options Matrix

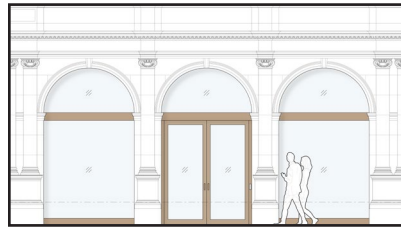

**Original Option**



**Modified Option**

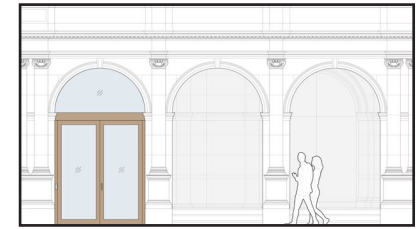

**BLC Suggestion**

**Pros**

- + Provides a 24/7 weather controlled accessible entry from plaza.
- + Provides a symmetrical design solution for this portico.

- + Provides a symmetrical design solution for this portico.
- + Provides a 24/7 weather controlled accessible entry from plaza.
- + Minimal attachment points from glass storefront to back of arched openings.
- + New interventions are reversible.

- + (Suggestion A) Provides a symmetrical design solution for this portico.
- + (Suggestions A & B) Does not include new material (glass) to the architectural vocabulary of this area of the church.

**Cons**

- Introduces new material (glass) to the architectural vocabulary of this area of the church.
- New interventions are not reversible.

- Two sets of existing wood doors would need to be removed and stored.
- Introduces new material (glass) to the architectural vocabulary of this area of the church.
- Lowers portico/vestibule floor and requires new stone veneer to match existing facade.

- Lowering the portico and placing stairs directly adjacent to the egress doors without a landing is not code compliant.
- Suggested glass doors just in front of elevator doors do not provide required clearances and is not code compliant.
- Exterior exposed elevator is not recommended by elevator expert consultant.
- New vestibule would require permanent alterations to the existing stone facade detail.

**For Reference Only**

Not Intended to be Reviewed at Hearing  
Unless Necessary to Answer Any Questions

# Original Design Concept

Presented at July 27, 2021 Boston Landmarks Commission Hearing

# Original Design Concept

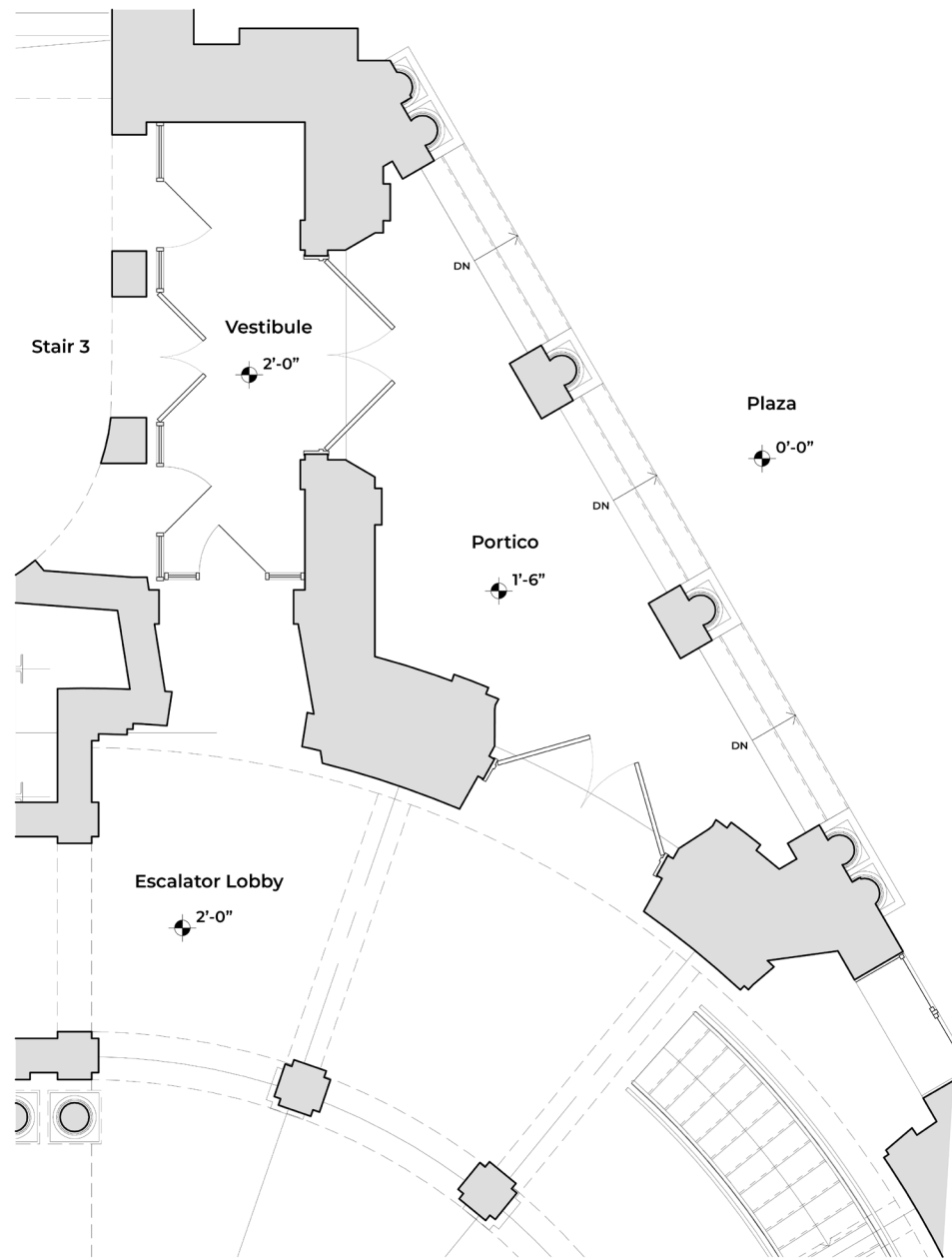

Plan - Existing

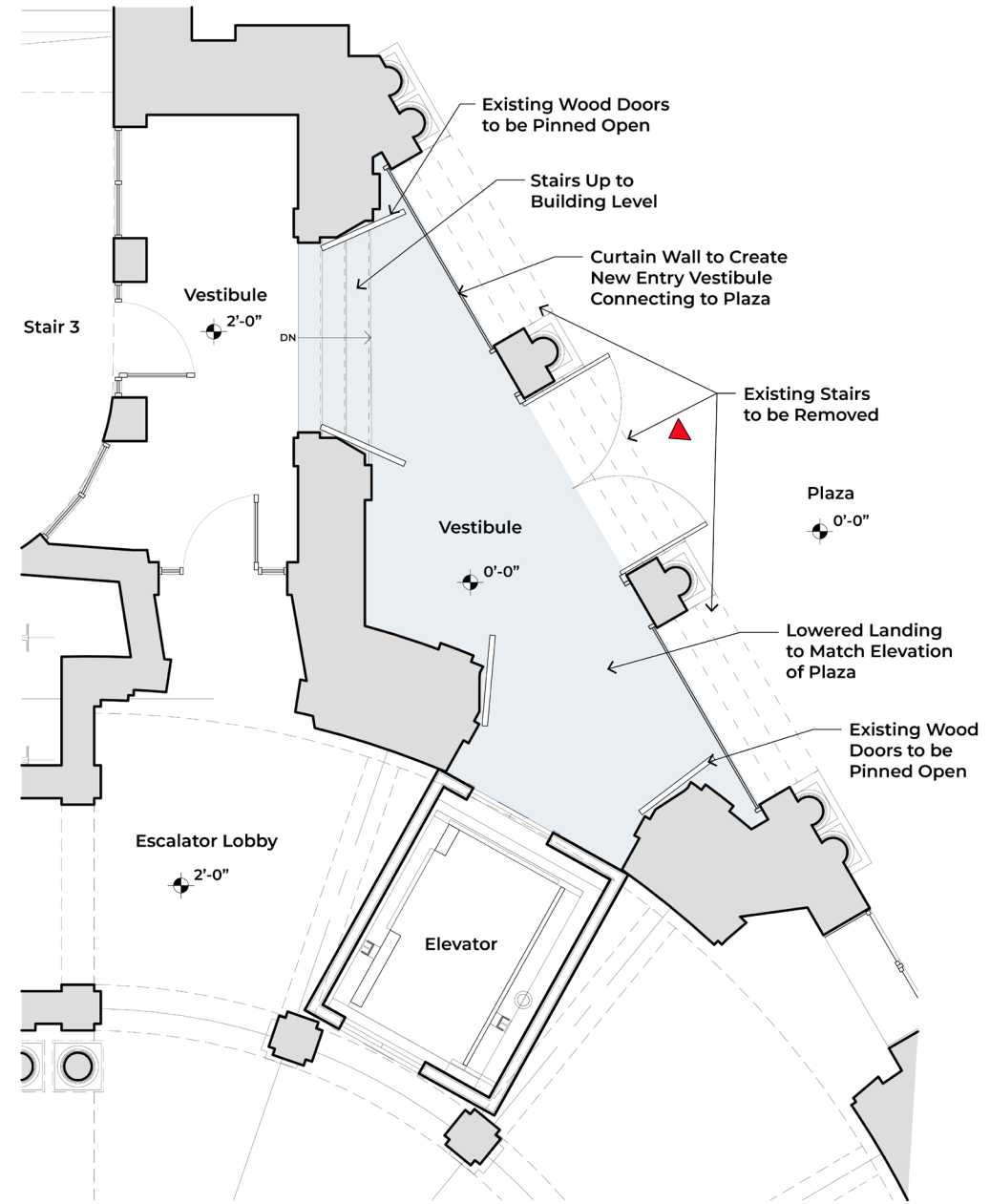

Plan - Proposed

# Original Design Concept

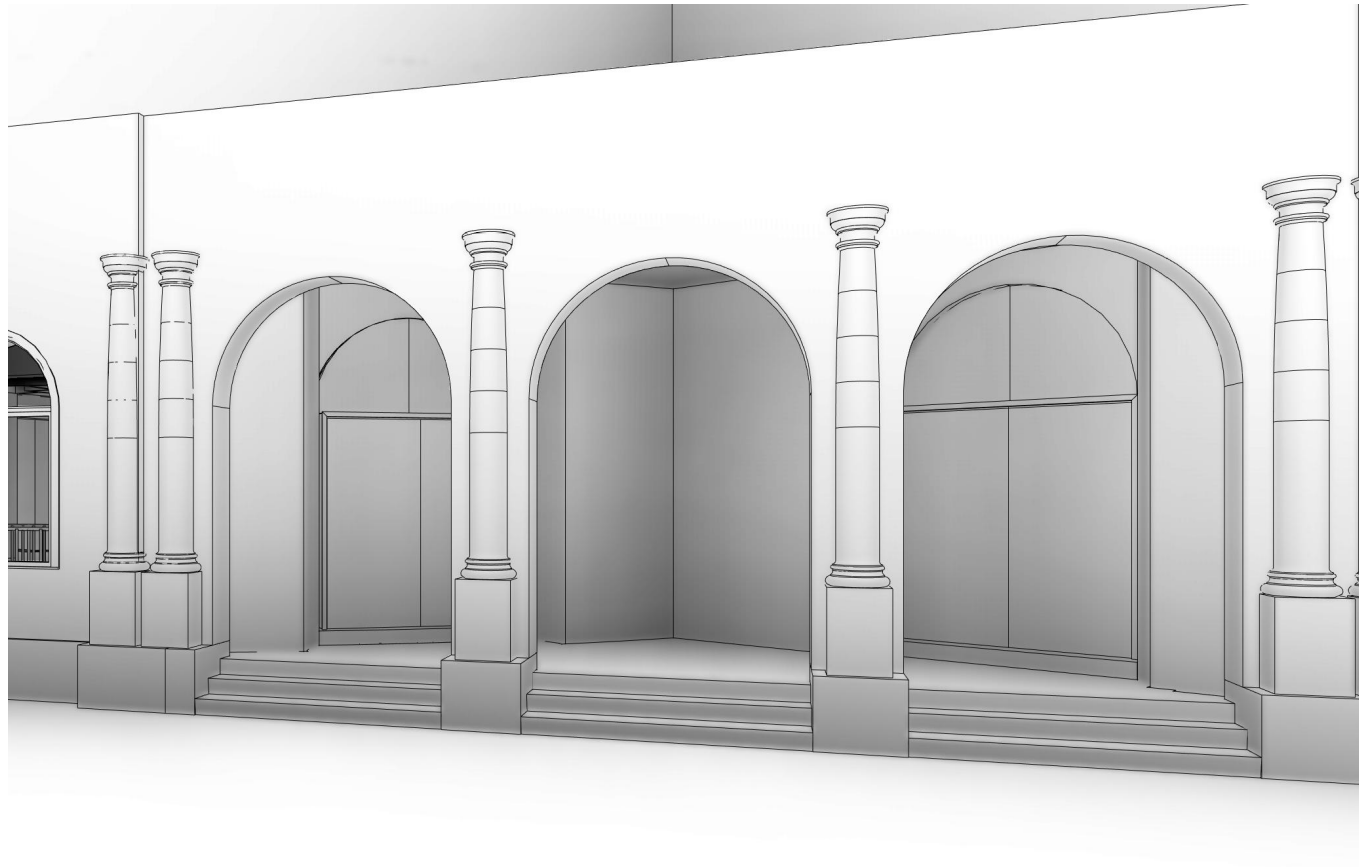

**3D Conceptual View – Existing**



**3D Conceptual View – Proposed**

# Original Design Concept

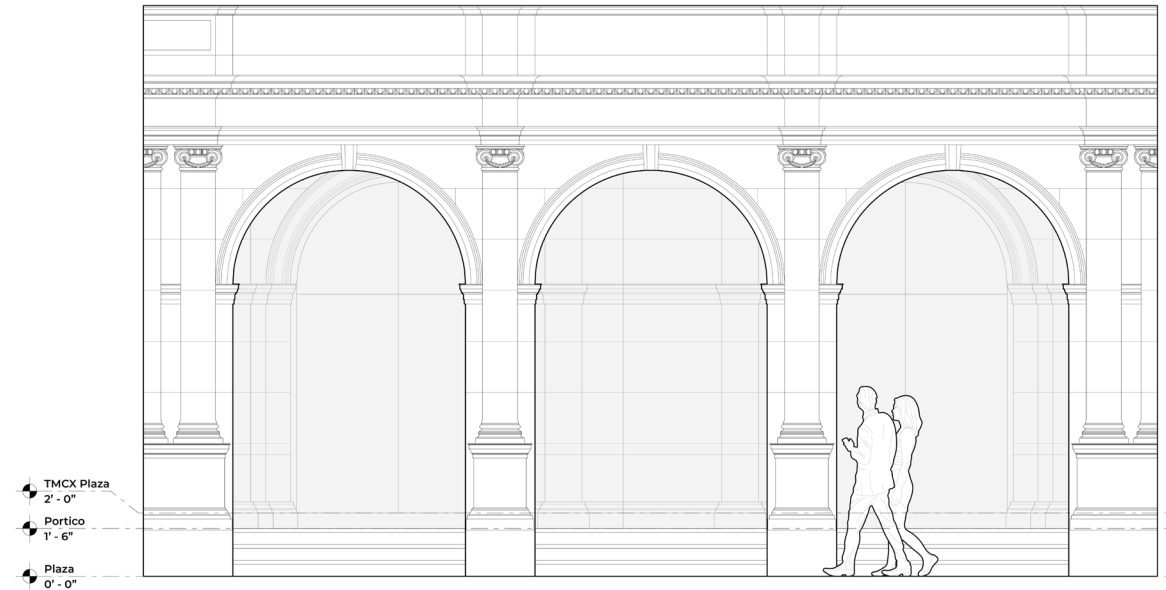

**Exterior Elevation – Existing**



**Exterior Elevation – Proposed**

Frame Mounted ADA Push Button Operator  
Bronze Double Doors

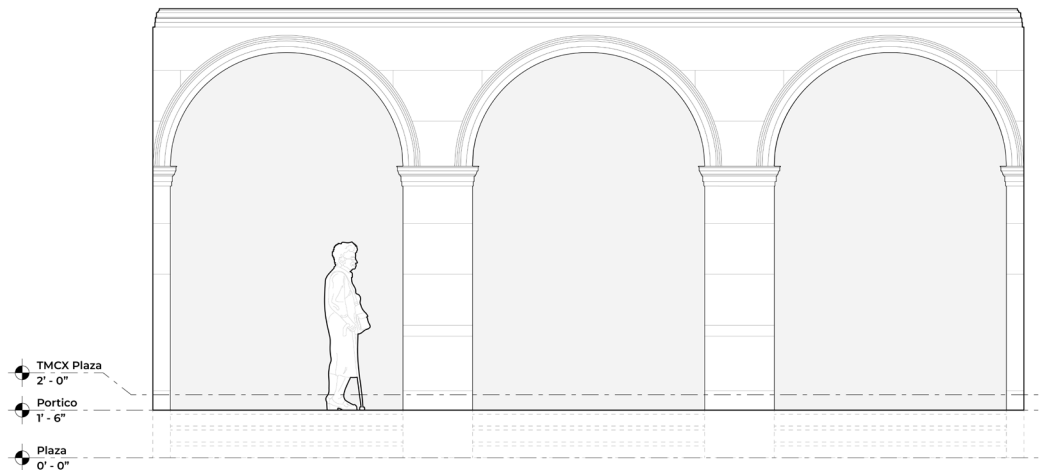

**Interior Elevation – Existing**

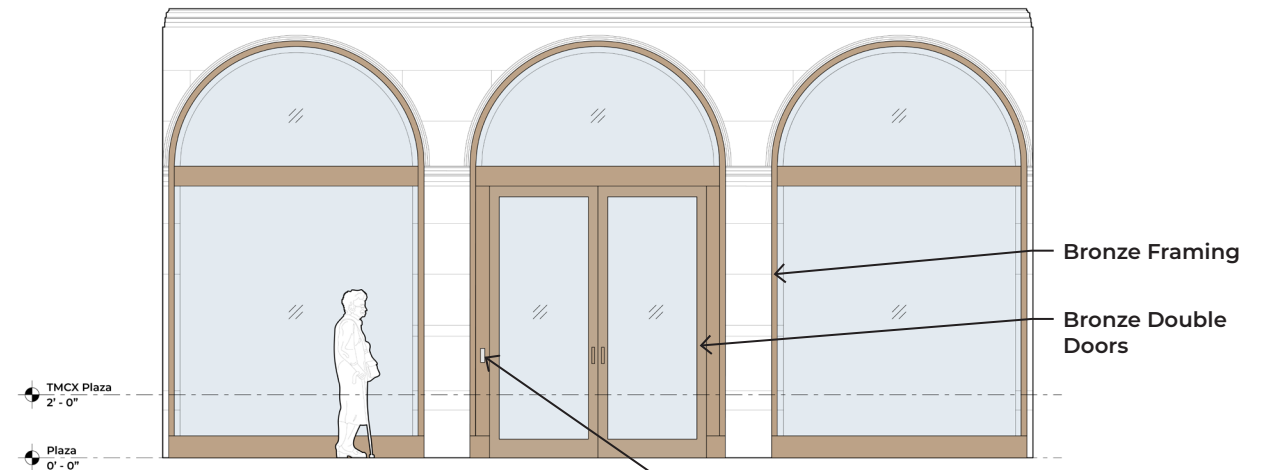

**Interior Elevation – Proposed**

Frame Mounted ADA Push Button Operator

Bronze Framing  
Bronze Double Doors

# Original Design Concept

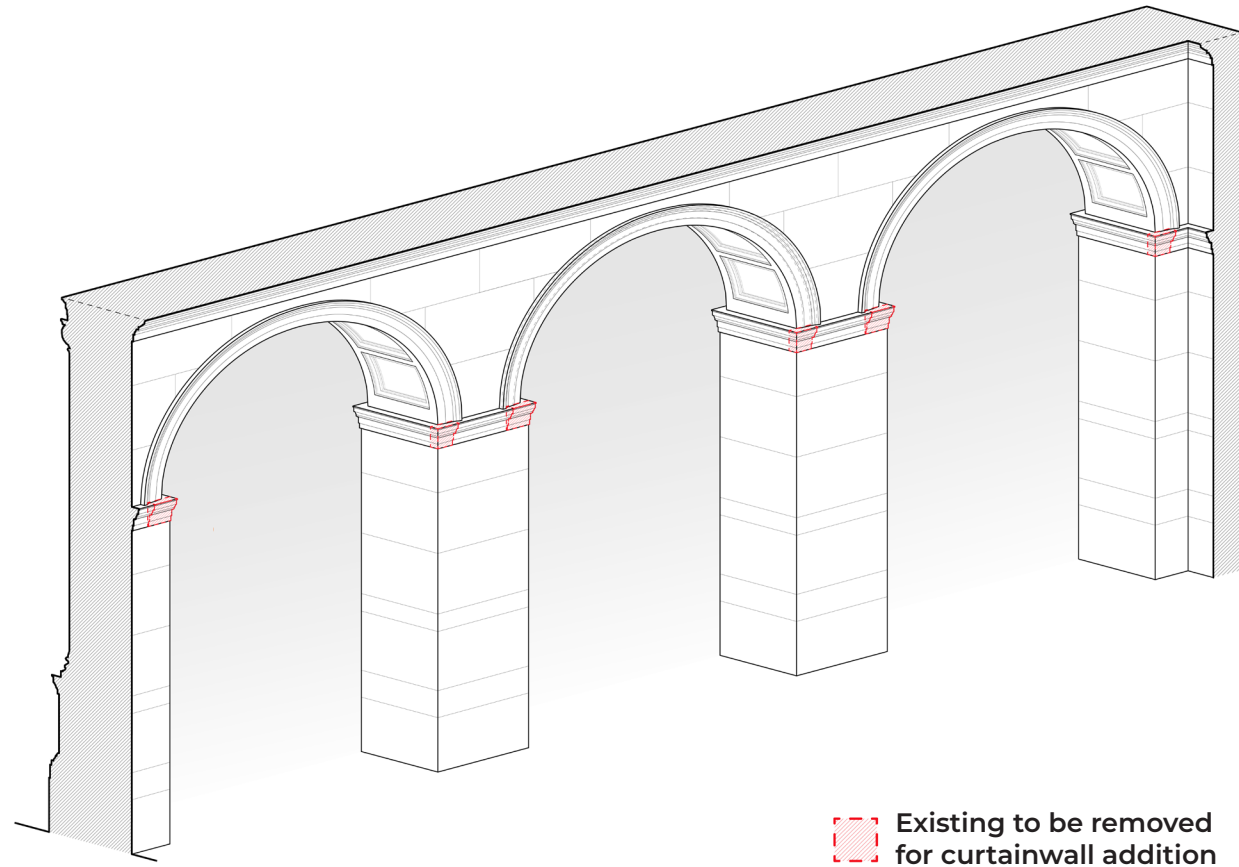

Interior Isometric – Existing

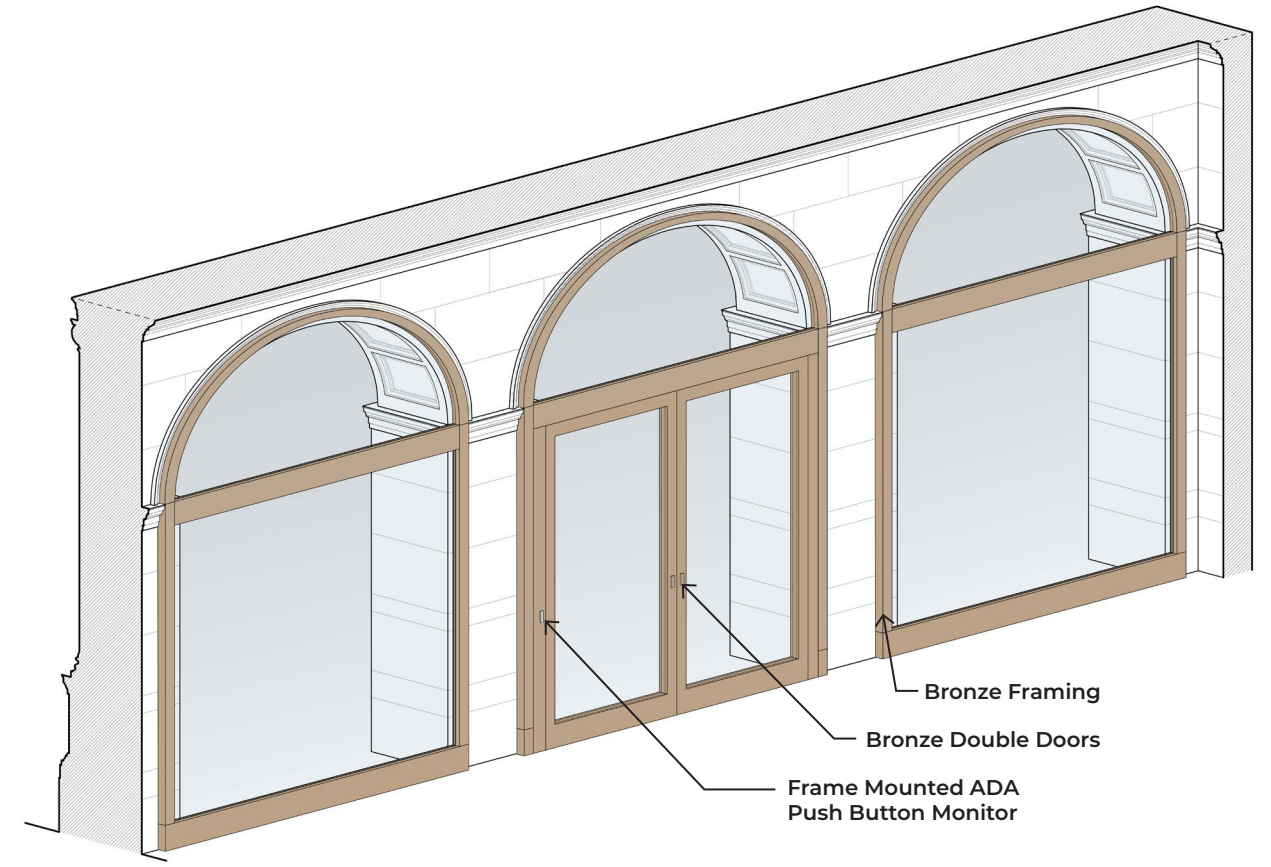

Interior Isometric – Proposed



# Original Design Concept

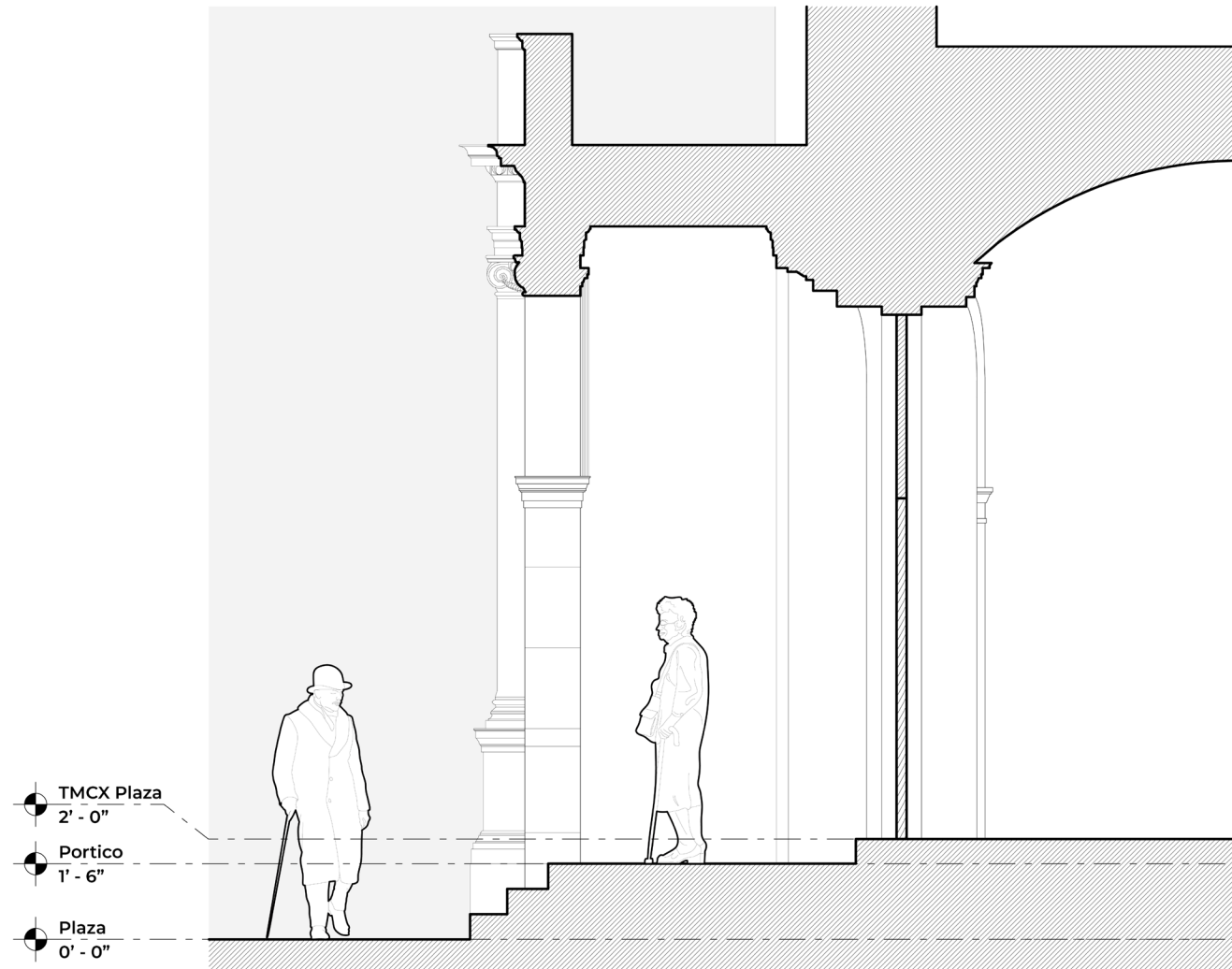

Section at Vestibule and New Elevator – Existing

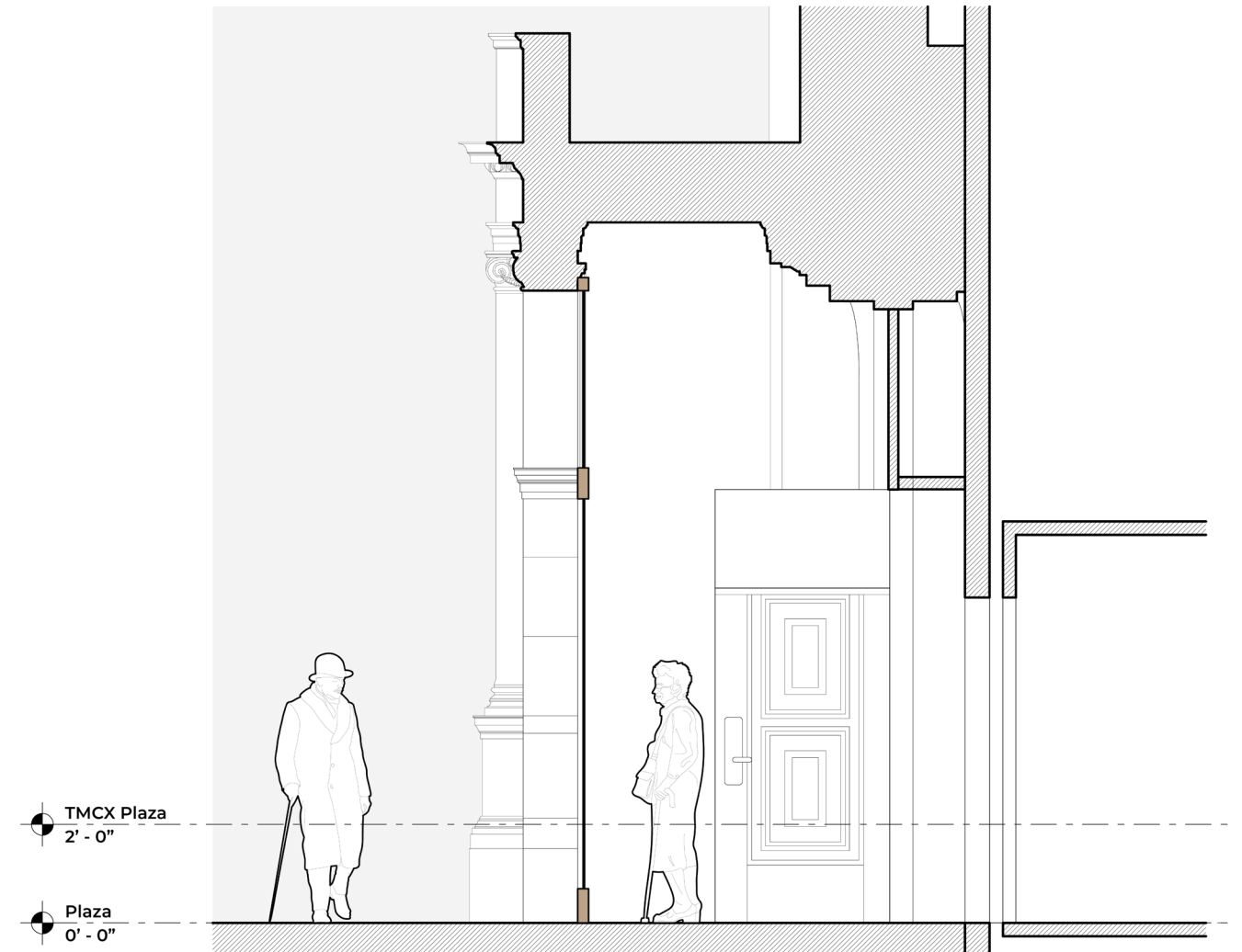

Section at Vestibule and New Elevator – Proposed