

For quick access, place your favorites here on the favorites bar. [Manage favorites now](#)

Boston, Massachusetts

Google

Street View - Oct 2020

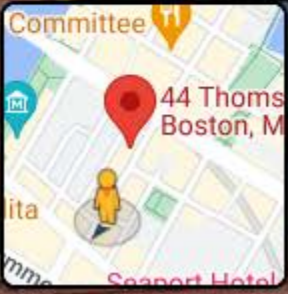

Google

For quick access, place your favorites here on the favorites bar. [Manage favorites now](#)

Boston, Massachusetts

Google

Street View - Oct 2020

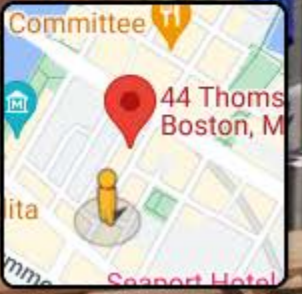

Google

For quick access, place your favorites here on the favorites bar. [Manage favorites now](#)

358 Thomson Pl
 Boston, Massachusetts

Google

Street View - Apr 2021

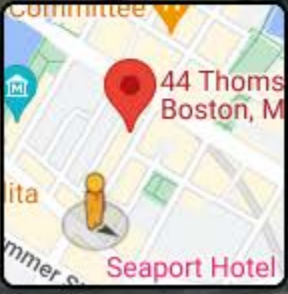

For quick access, place your favorites here on the favorites bar. [Manage favorites now](#)

47 Thomson Pl
 Boston, Massachusetts

Google

Street View - Oct 2020

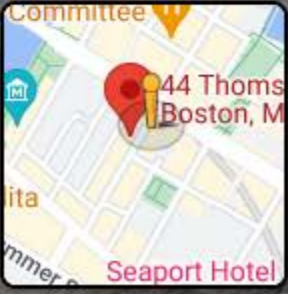

Google

For quick access, place your favorites here on the favorites bar. [Manage favorites now](#)

55 Thomson Pl
Boston, Massachusetts

Google

Street View - Oct 2020

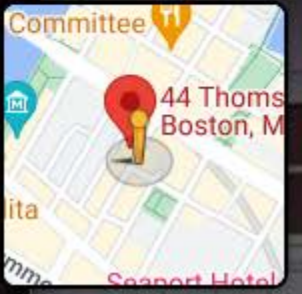



EXISTING



PROPOSED

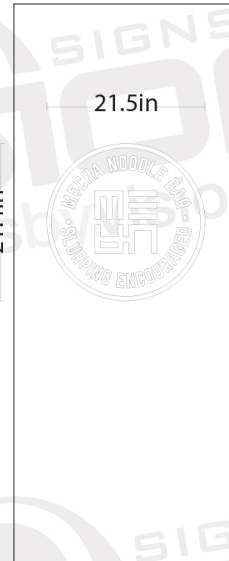

Contour Cut
White Vinyl | 1x

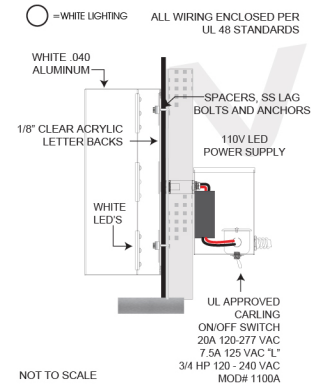

NOT TO SCALE



PMS: Orange 021 C

24" Set Halo Lit Letters | Brown Aluminum Pan | 1x Set

FABRICATED .063 ALUMINUM
SIGN CABINET

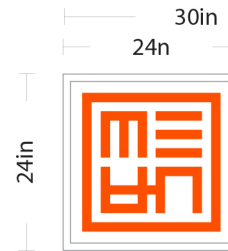
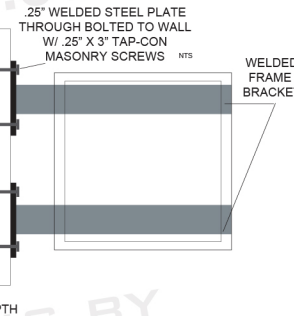
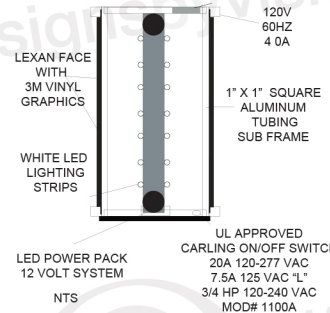

LED Lit Blade Sign | 1x

PROOF

PLEASE MARK THE RELEVANT BOX & SIGN

PROOF APPROVED

PROOF APPROVED WITH REVISIONS

SIGNATURE

55 Thomson Pl

Boston, Massachusetts



Google



Street View - Oct 2020



TRADER JOE'S

TRADER JOE'S

trillium



Google

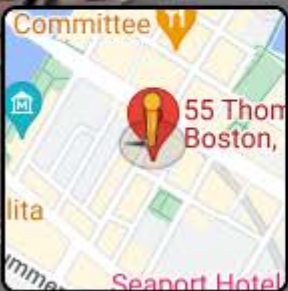



64in

27in

24" Set Halo Lit Letters
Brown Aluminum Pan | 1x Set

○ = WHITE LIGHTING ALL WIRING ENCLOSED PER UL 48 STANDARDS

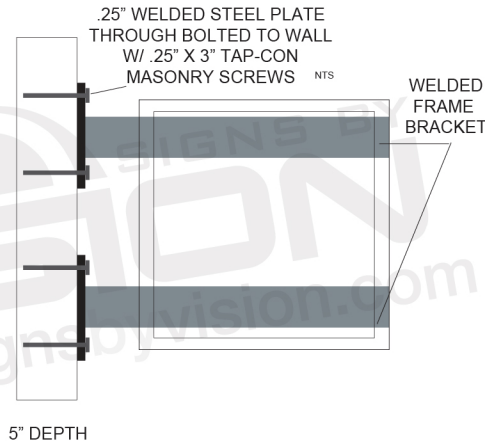
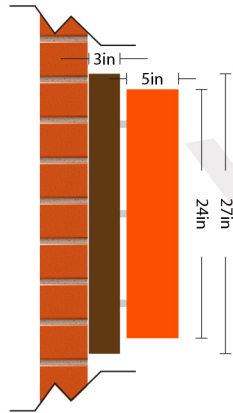
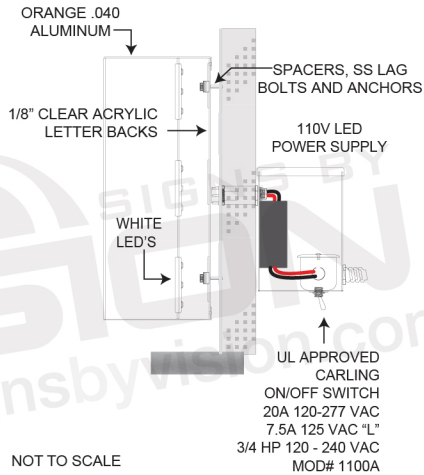

FABRICATED .063 ALUMINUM SIGN CABINET

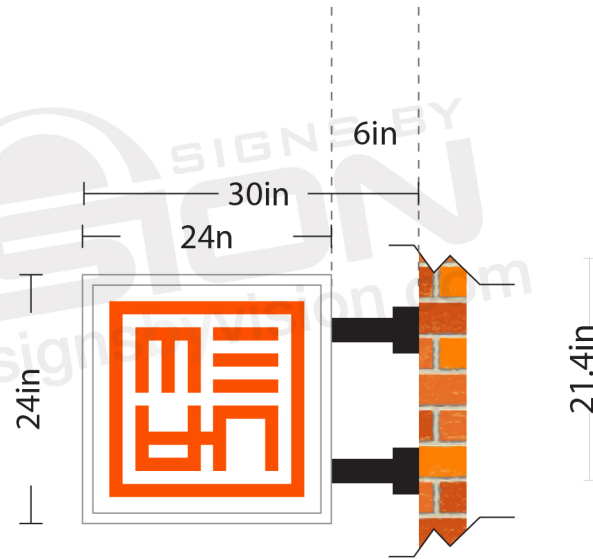
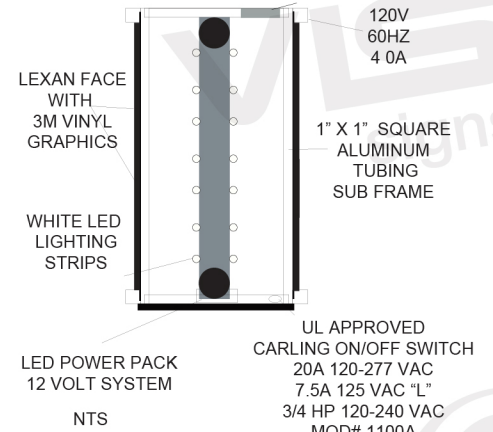

LED Lit Blade Sign | 1x



Contour Cut White Vinyl | 1x

PROOF

PLEASE MARK THE RELEVANT BOX & SIGN

PROOF APPROVED

PROOF APPROVED WITH REVISIONS

X SIGNATURE

REQUIRED DOCUMENTATION: Please include all required documentation with this application; review instructions carefully for details.

ESTIMATED COST OF PROPOSED WORK: \$3,750.00

IV. DULY AUTHORIZED SIGNATURES (both required)

The facts set forth above in this application and accompanying documents are a true statement made under penalty of perjury.

APPLICANT Ashlea Andrews OWNER* David Wiggins
 *(If building is a condominium or cooperative, the chairman must sign.)

PRINT Ashlea Andrews PRINT David Wiggins

Environment Department personnel cannot be responsible for verifying the authority of the above individuals to sign this application. Misrepresentation of signatory authority may result in the invalidation of the application.

UNSIGNED OR PARTIALLY SIGNED FORMS WILL BE REJECTED

THIS APPLICATION IS NOT COMPLETE WITHOUT SIGNATURES, FEES AND REQUIRED DOCUMENTATION. The checklist below is for reference only: Please refer to the detailed application instructions for deadlines, fee schedule and required documentation specific to your proposal.

- COMPLETED APPLICATION FORM
- APPLICATION FEE (Check or money order made payable to City of Boston; see fee schedule in Instructions)
- DESCRIPTION OF WORK (A brief description must be included on the front page; additional pages of detailed information may be attached. **Applications that only note "see attached" will not be accepted.**)
- PHOTOS OF EXISTING CONDITIONS
- DRAWINGS AND SPECIFICATIONS AS REQUIRED (See "documentation requirements" in instructions)