

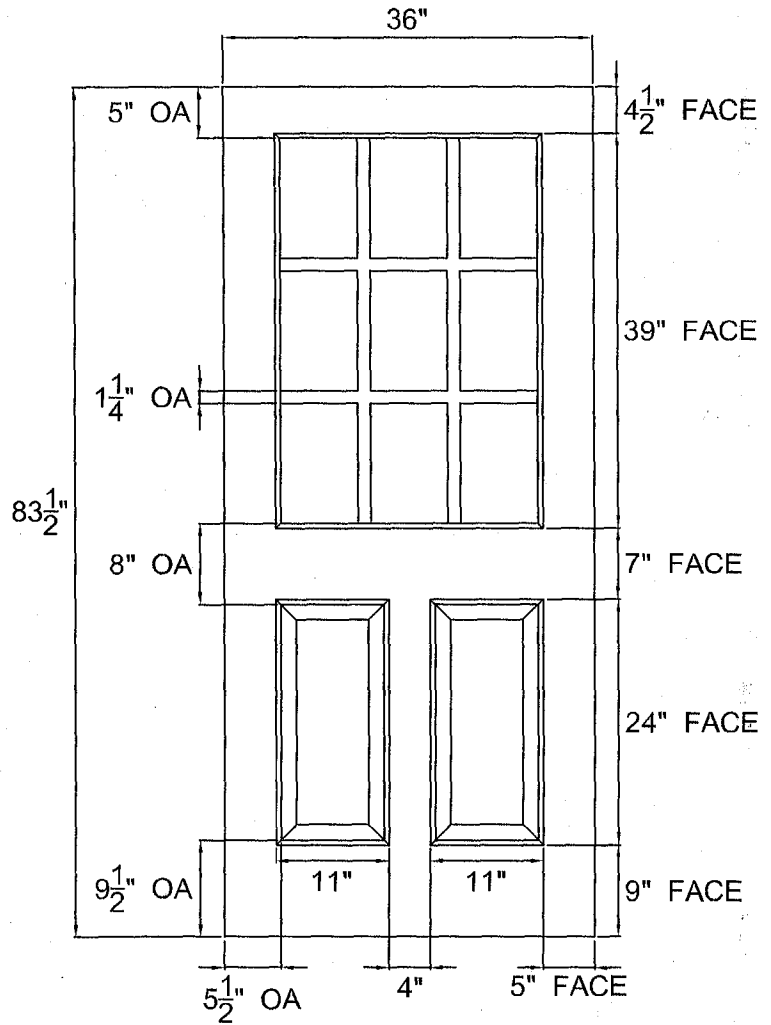

SLAB ONLY, NO PREP

Existing Frame to Remain

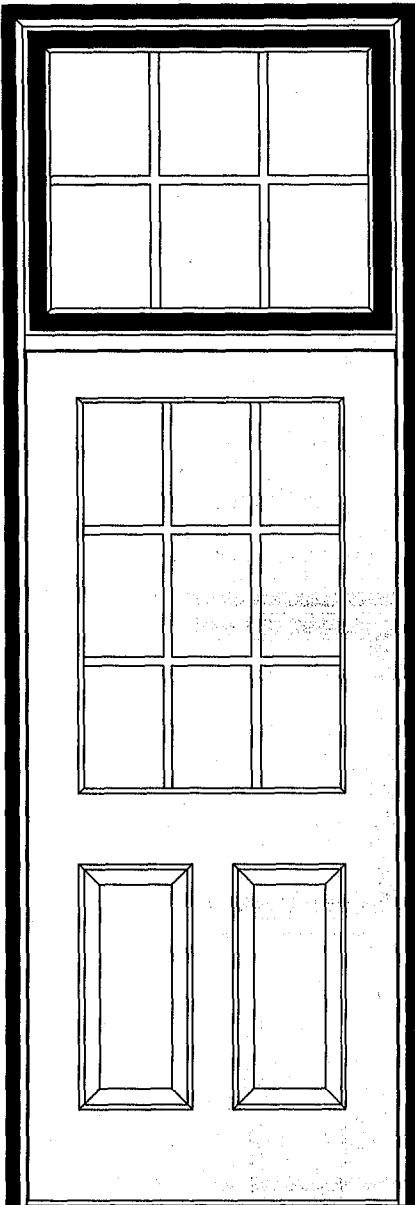

ROUGH OPENING MEASUREMENTS ARE DETERMINED BY ADDING 1" TO THE "OSJ" WIDTH AND 1/2" TO THE "OSJ" HEIGHT

	Dallas Millwork Inc. PO Box 549 Hiram, GA. 30141 770-943-3909 770-943-3900 FAX	Architectural Window Corp.-Boston	DRAWING # ER10112203
	APPROVED BY: X _____	127 Mount Vernon	DATE: 10-11-22
			REV. #:
			REV DATE:

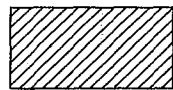
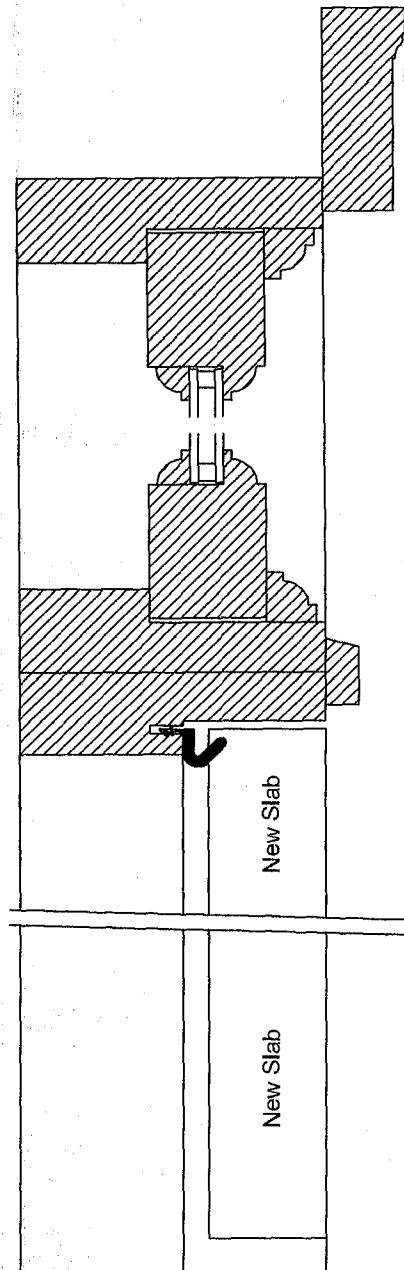

Existing Frame to Remain

ROUGH OPENING MEASUREMENTS ARE DETERMINED BY ADDING 1" TO THE "OSJ" WIDTH AND $\frac{1}{2}$ " TO THE "OSJ" HEIGHT



Dallas Millwork Inc.
 PO Box 549 Hiram, GA. 30141
 770-943-3909 770-943-3900 FAX
 APPROVED BY:
 X _____

**Architectural Window
 Corp.-Boston**
 127 Mount Vernon

DRAWING #
 ER10112203
DATE: 10-11-22
REV. #:
REV DATE:

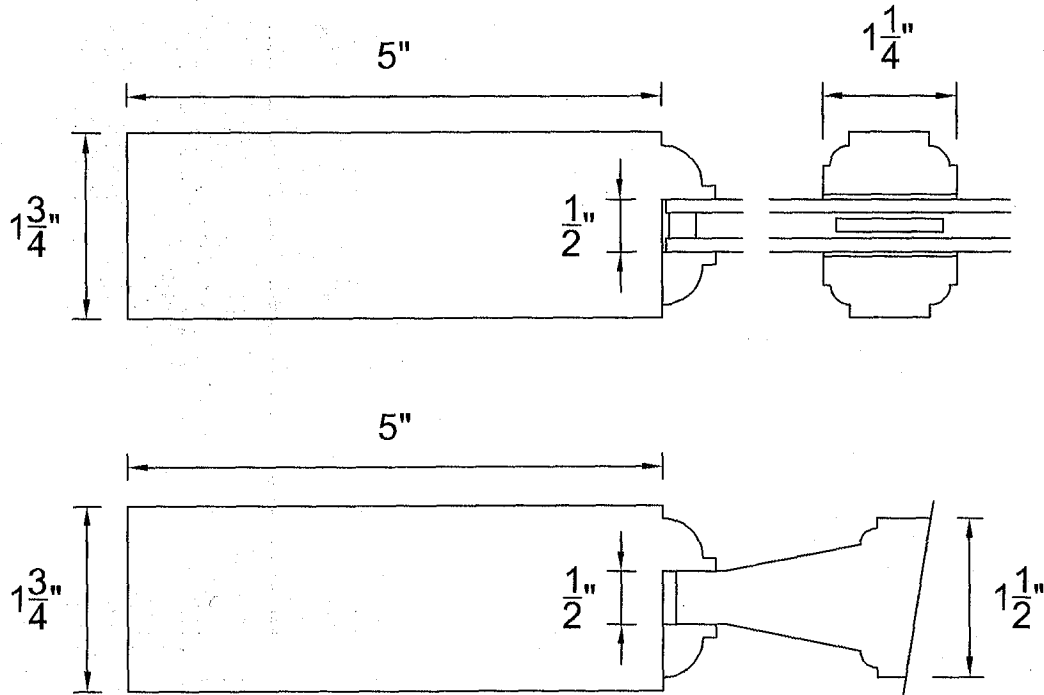

ROUGH OPENING MEASUREMENTS ARE DETERMINED BY ADDING 1" TO THE "OSJ" WIDTH AND 1/2" TO THE "OSJ" HEIGHT

	Dallas Millwork Inc. PO Box 549 Hiram, GA. 30141 770-943-3909 770-943-3900 FAX	Architectural Window Corp.-Boston	DRAWING # ER10112203
	APPROVED BY: X _____	127 Mount Vernon	DATE: 10-11-22
			REV. #:
			REV DATE: