

# 51 Melcher Street

Fort Point, South Boston, MA

*Design Review – Streetscape Improvements*

MARCH 9, 2023



# Summary of Status

- March 2022 - Rehabilitation scope of work approved by FPCLDC with provisos
- April 2022 – Updated scope of work RE: elevator approved by FPCLDC
- November 2022 – Updated scope of work RE: rooftop and ground mechanicals (upgraded for electrification) approved by FPCLDC

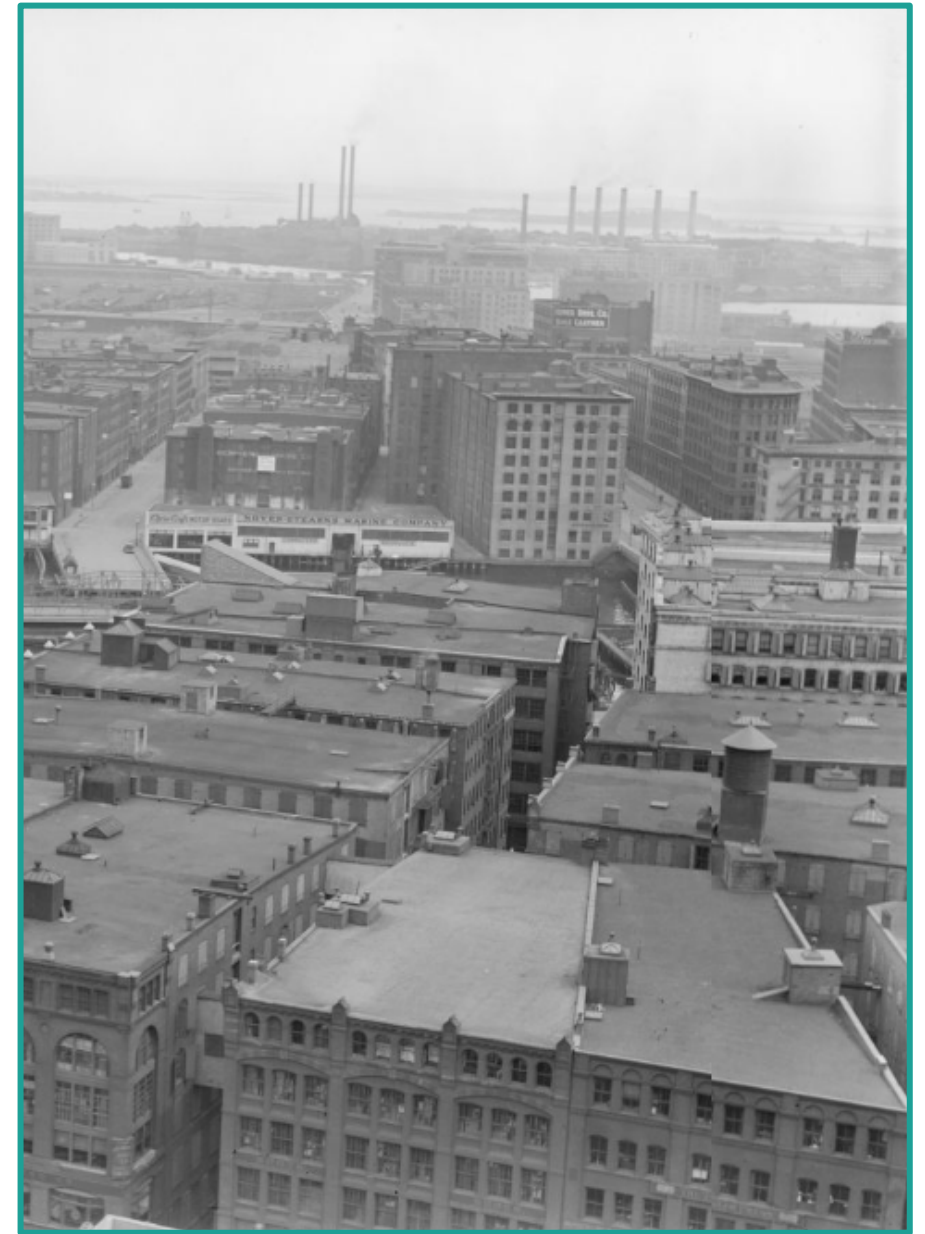

# Tree Pits

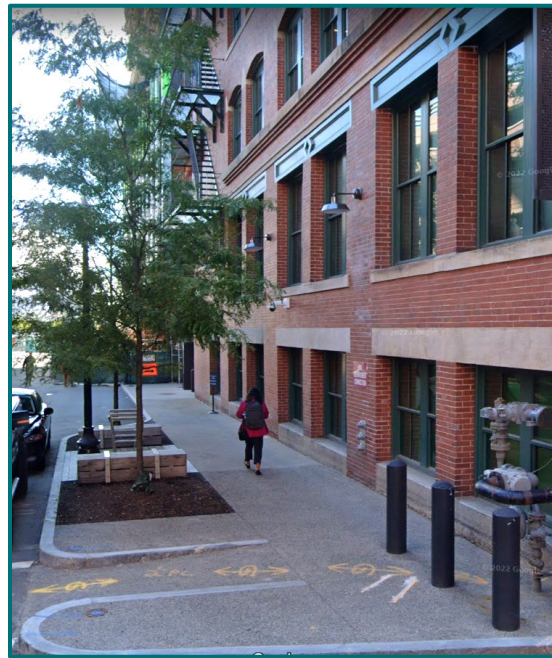

Representative tree pit at 5 Necco Street.



Existing Melcher Street tree pits.

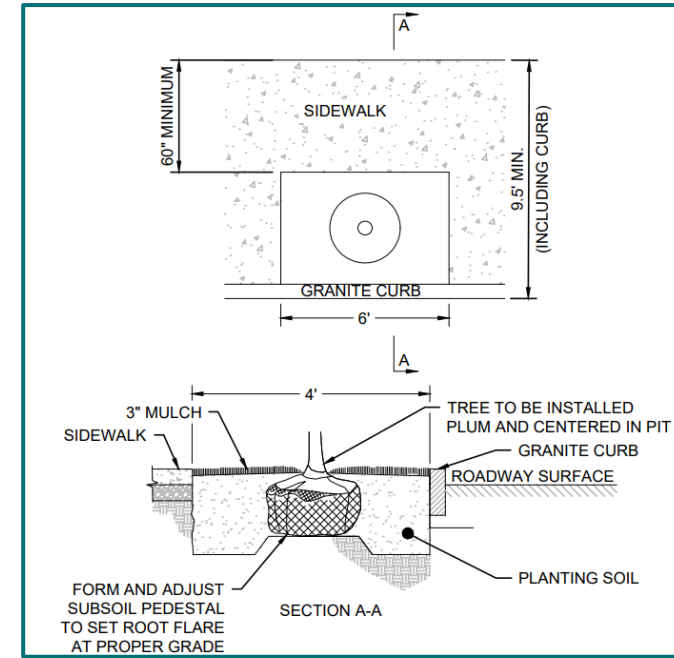

City of Boston PWD Standard 4' x 6' Tree Pit

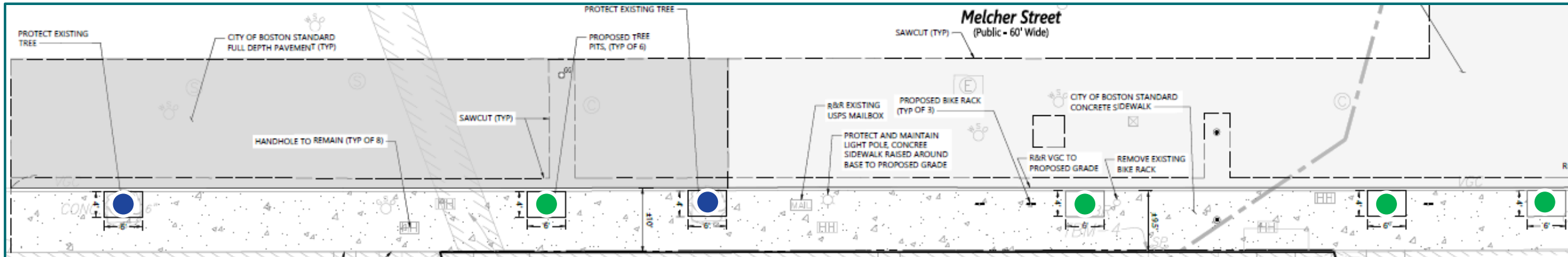

- New Tree Pit
- Existing Tree Pit

# Bike Racks

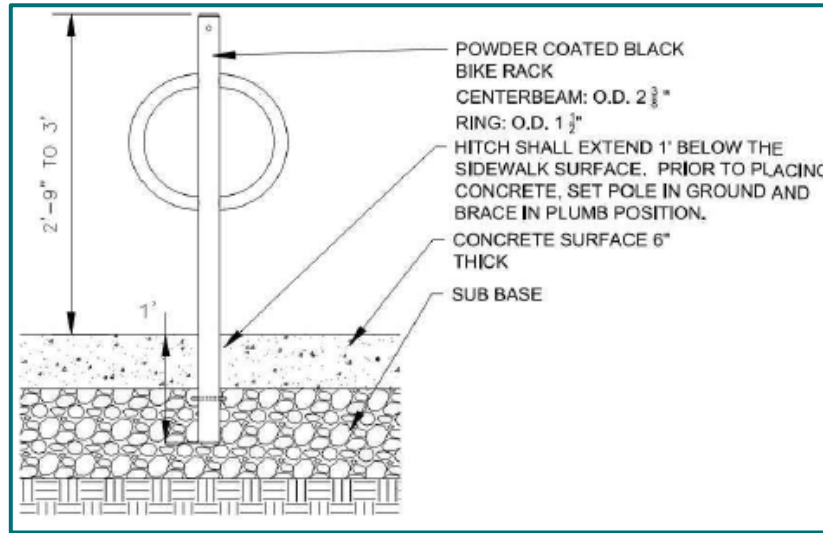

City of Boston PWD Standard Bike Rack



Existing bike rack on Melcher Street (representative of proposed bike racks).

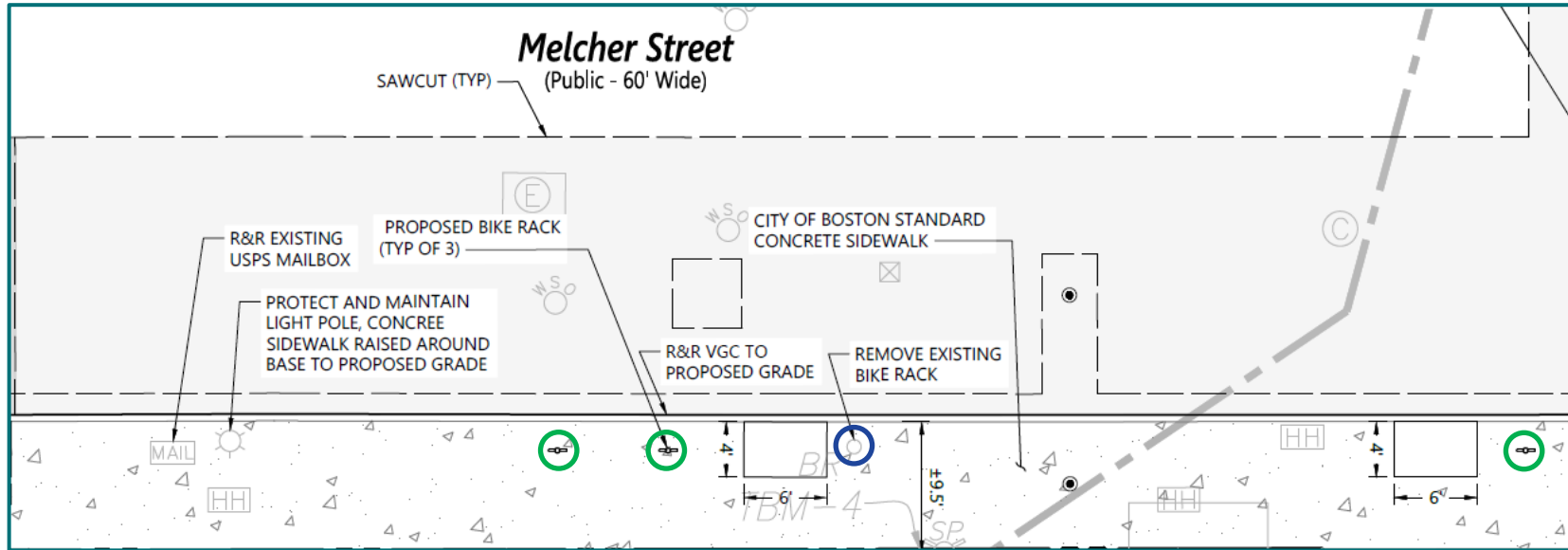

○ New Bike Rack

○ Existing Bike Rack

# Bollards



Existing Melcher Street crosswalk showing approximate location of proposed bollards.

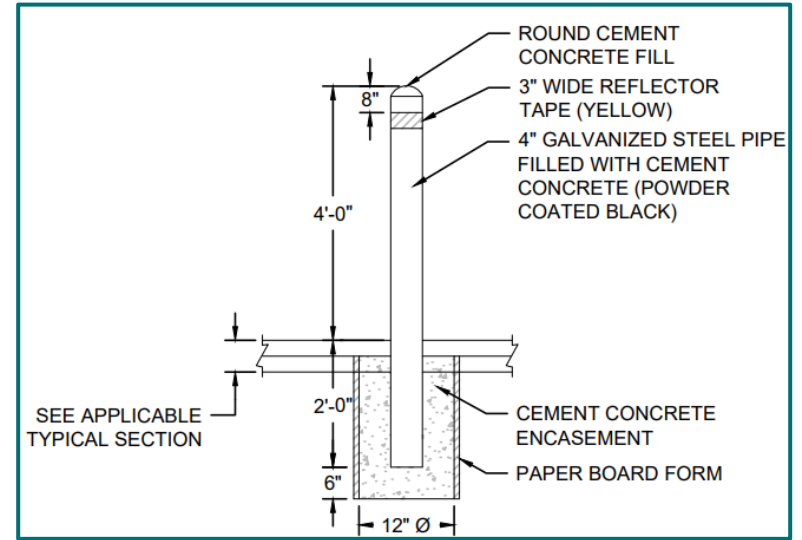

City of Boston PWD Standard Bollard



Representative bollards within public ROW on Sleeper Street.

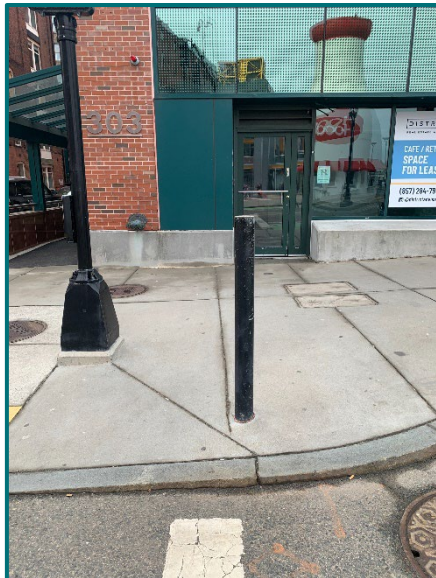

Representative bollard within public ROW at 303 Congress Street.

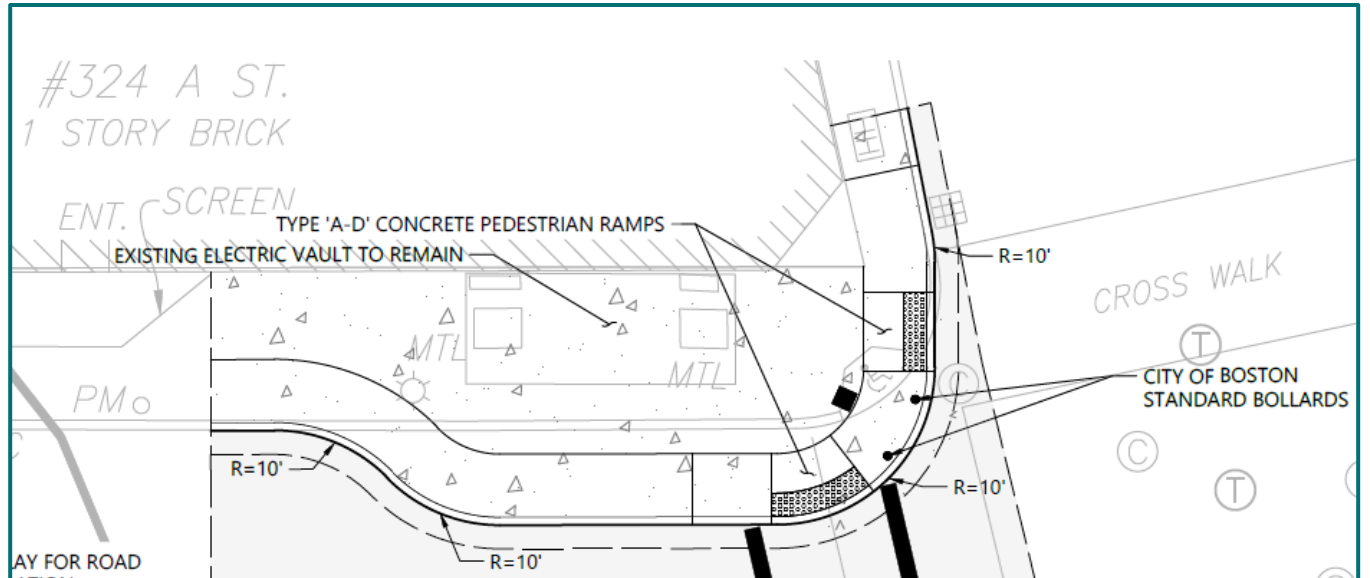

# Melcher and A Street Intersection Improvements

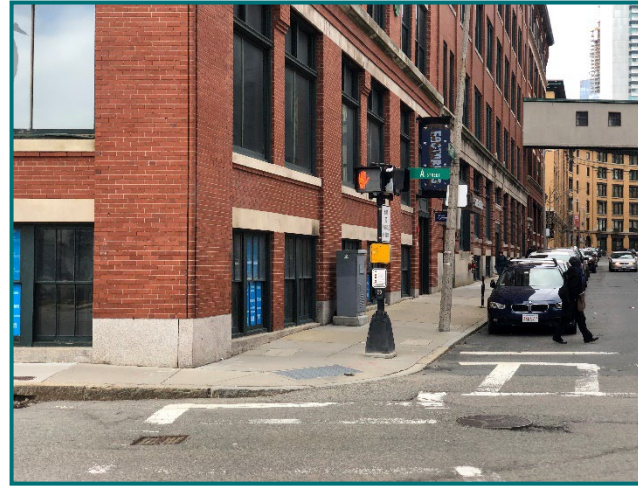
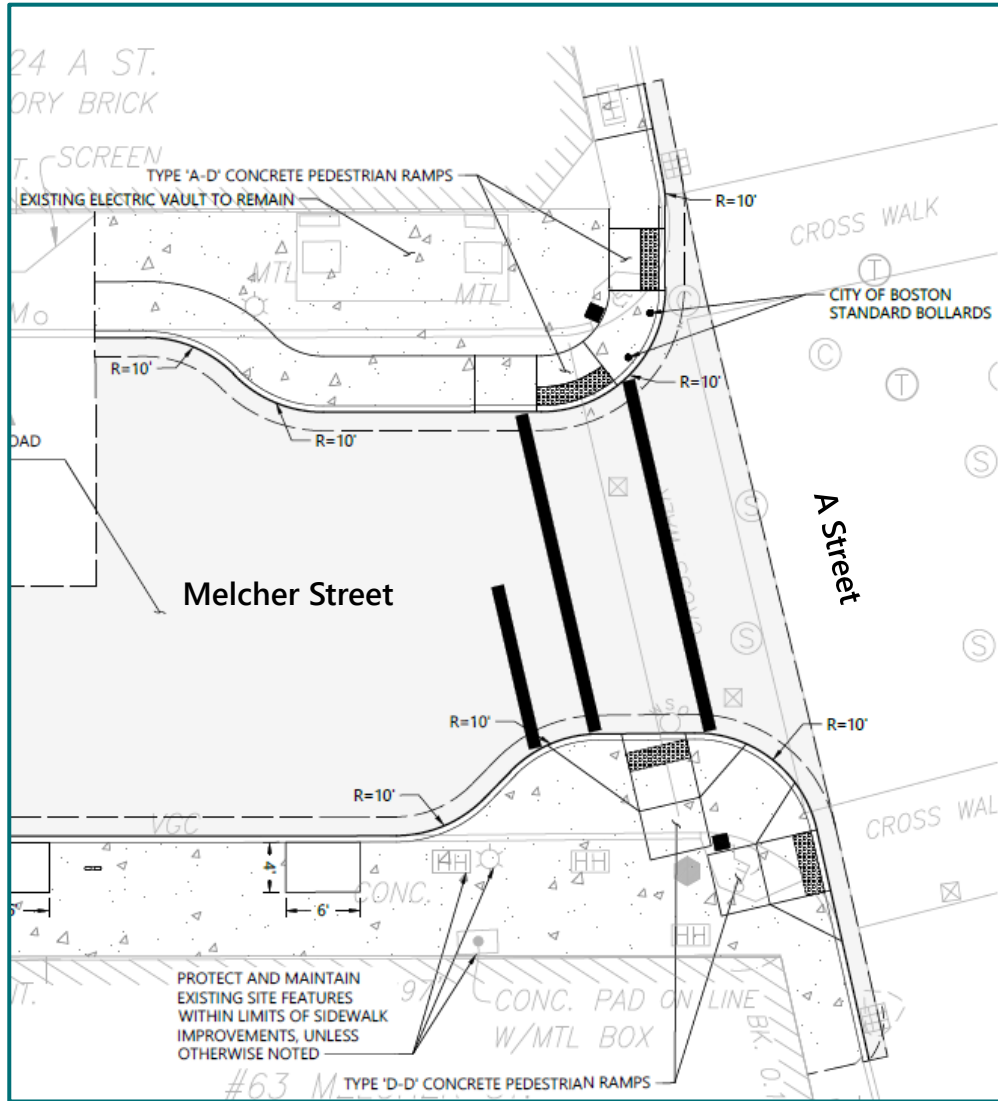

Melcher and A Street intersection (51 Melcher Street side)



Melcher and A Street intersection (19 Melcher Street side)

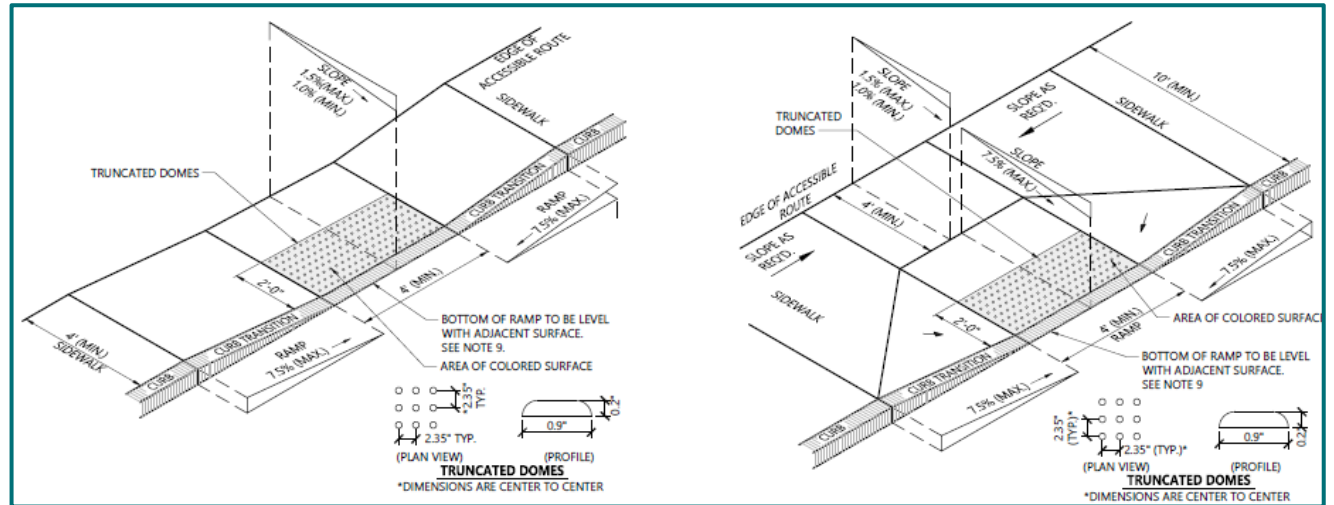

City of Boston PWD Type 'A-D' Accessible Curb Ramp

City of Boston PWD Type 'D-D' Accessible Curb Ramp