

BOQUERIA

EXTERIOR LOUVERS SUBMISSION



25 THOMSON PLACE

BOQUERIA

DESIGN REVIEW TOPICS

LOCATION OF BUILDING WITHIN DISTRICT

EXISTING PHOTOS

PROPOSED LOUVER ELEMENTS

- 25 THOMSON EXISTING CONDITIONS
- 25 THOMSON LOUVER DESIGN
- 25 THOMSON LOUVER DETAILS

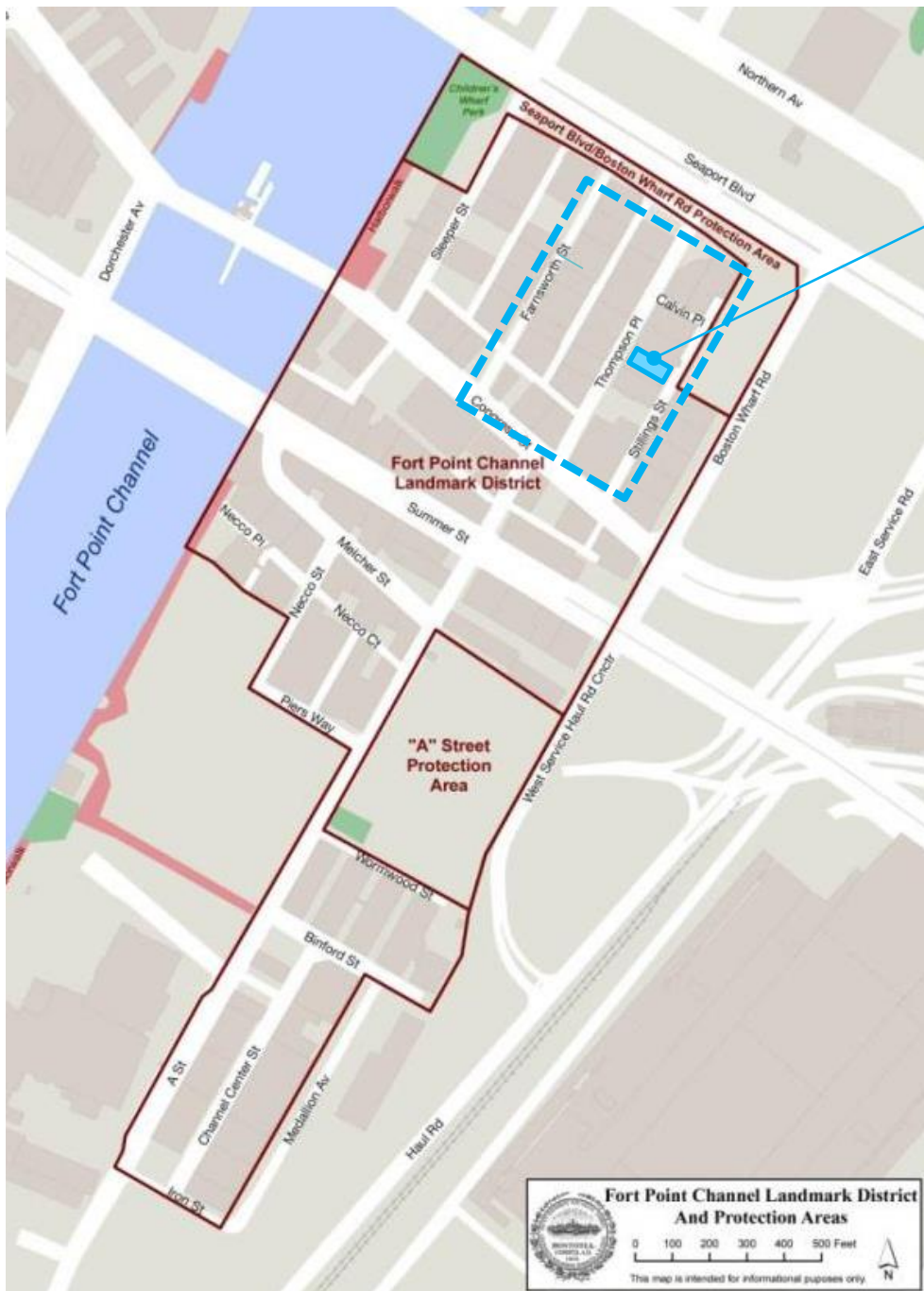

25 THOMSON PLACE

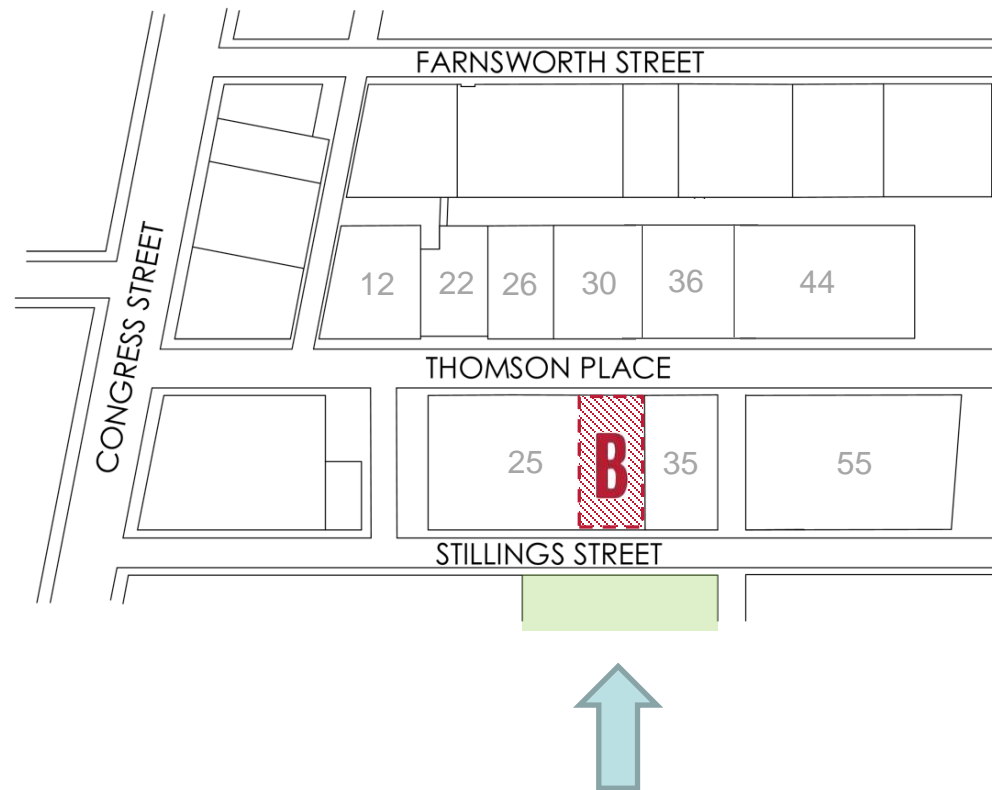

FORT POINT CHANNEL LANDMARK DISTRICT

PROJECT LOCATION MAPS



EXISTING CONDITION PHOTO

25 THOMSON PLACE – VIEW FROM STILLINGS STREET

BOQUERIA

4.13.2023



EXISTING CONDITION PHOTO

25 THOMSON PLACE – VIEW FROM STILLINGS STREET



EXISTING CONDITION PHOTO

25 THOMSON PLACE – VIEW FROM CORNER OF STILLINGS STREET & AUTUMN LANE



EXISTING CONDITION PHOTO

25 THOMSON PLACE – VIEW FROM STILLINGS STREET



SIGHTLINES FROM PARK OBSTRUCTED BY TREES

6 FT HEIGHT FOR PEDESTRIAN EXPERIENCE

EXISTING CONDITION PHOTO

25 THOMSON PLACE – VIEW FROM STILLINGS STREET

BOQUERIA

4.13.2023



RESIDENCE INN - VENT DETAIL ON THOMSON PLACE



RESIDENCE INN - VENT DETAIL ON STILLINGS STREET

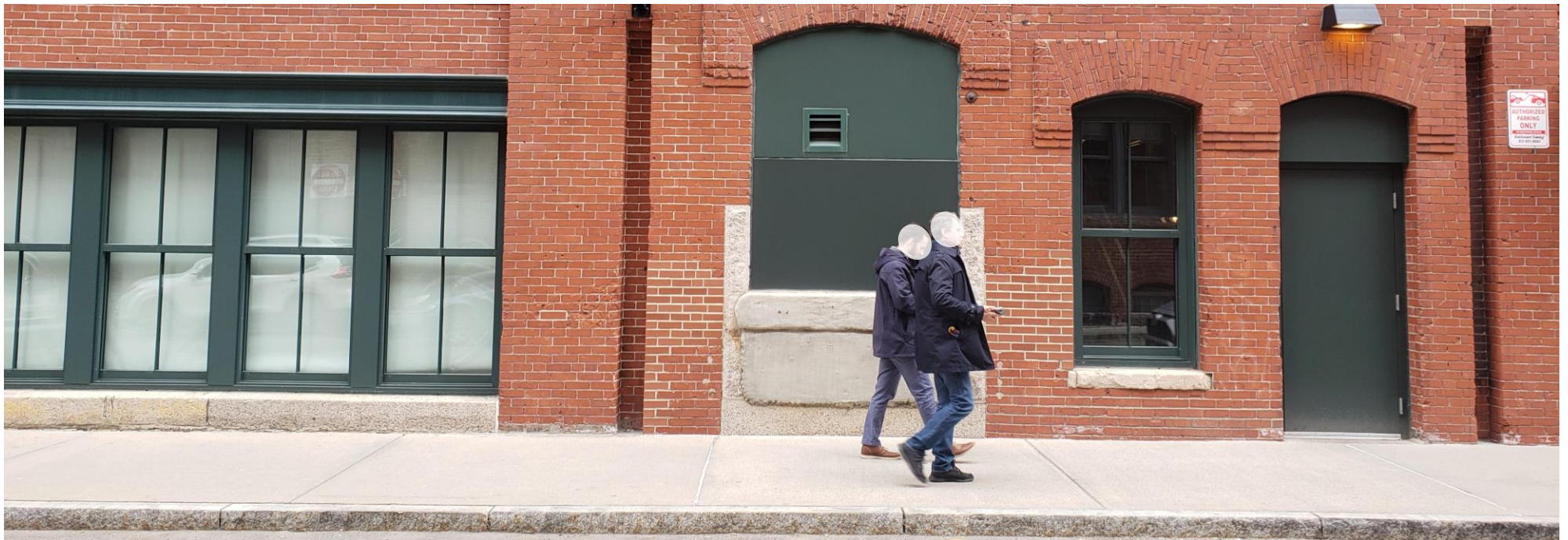

RESIDENCE INN - VENT DETAIL ON THOMSON PLACE WITH PEDESTRIANS



RESIDENCE INN - VENT DETAIL ON STILLINGS STREET



RESIDENCE INN - VENT DETAIL ON STILLINGS STREET

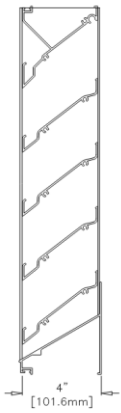

LOUVER DETAIL
(PAINT COLOR TO MATCH STOREFRONT)

REPLACE EXISTING LOUVER IN WOOD LINTEL

NEW EXHAUST LOUVERS TO REPLACE TRANSOM GLAZING

NEW INTAKE LOUVERS TO REPLACE TRANSOM GLAZING
PAINTED WOOD DIVIDERS TO MATCH AND ALIGN WITH STOREFRONT BELOW

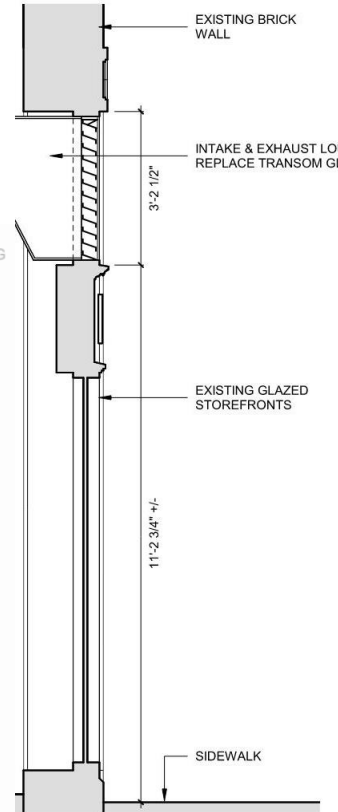
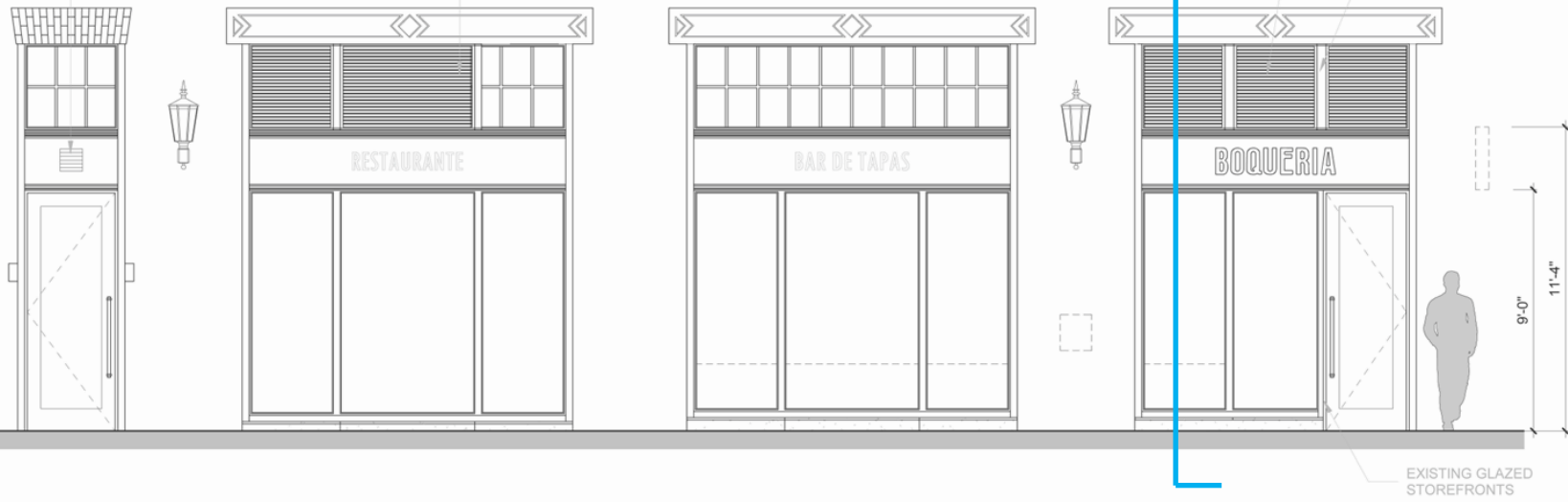

EXHAUST
SURFACE AREA: 9.75 SF
FREE AREA REQ: 1.25 SF

KITCHEN EXHAUST
SURFACE AREA: 32.07 SF
FREE AREA REQ: 12.50 SF

FRESH AIR INTAKE
SURFACE AREA: 26.06 SF
FREE AREA REQ: 14.00 SF

PROPOSED ELEVATION & WALL SECTION

STILLINGS STREET – EXTERIOR ELEVATION & WALL SECTION



PERSPECTIVE OF LOUVERS AT FACADE

CONCEPTUAL RENDERING OF STILLINGS STREET VIEW

BOQUERIA

4.13.2023



RENDERING OF LOUVERS AT FACADE

ELEVATION OF STILLINGS STREET VIEW

BOQUERIA

4.13.2023



BOQUERIA