

Sleeper, Congress and A Streets

Fort Point Channel Landmark District Commission
April 13, 2023



Project Address:

- Sleeper Street from Seaport Boulevard to Congress Street
- Congress Street from Sleeper Street to Boston Wharf Road
- A Street from Congress Street to Melcher St.

Urban Design and Engineering Services Relative to the Reconstruction of Sleeper, Congress and A Streets in the City of Boston

Plan Approved 1/23/2023 with Provisos



- Eliminate “pot belly” trash receptacles and use vertical trash receptacles
- Look into ways to mitigate the pigeon issue on A Street
- Preference for raw galvanized metal as opposed to painted black
- Bike racks embedded when installed to make more sturdy as opposed to surface mount installation

Proviso: Preference for galvanized steel



pavers and bike rack



bench without back



bench with back



trash receptacle

Fort Point Standards, Summer Street Precedent,
City of Boston Standards (City will maintain)



alternative bench with galvanized steel

Furnishings

- Benches – SiteScapes ‘Westport’ – black finish (similar to Summer Street), City of Boston Standard (Alternative shown is Landscape Forms ‘Bancal’)
- Bike Rack – Dero Bike ‘Hitch Bike Rack’ – black finish (matches Summer Street, City of Boston Standard)
- Trash – Victor Stanley SD-42 – black finish (City of Boston Standard)

Bike rack and trash receptacle above come in galvanized steel;
Westport bench does not - alternative is shown (City does not
maintain rack, receptacle nor bench in galvanized steel)

Lighting Proposal



single light fixture



double light fixture

Materials

- Fort Point district fixture – LED luminaire, twin in selected locations only for required illumination

Fort Point Standards, Summer Street Precedent,
City of Boston Standards - Approved 1/23/2023

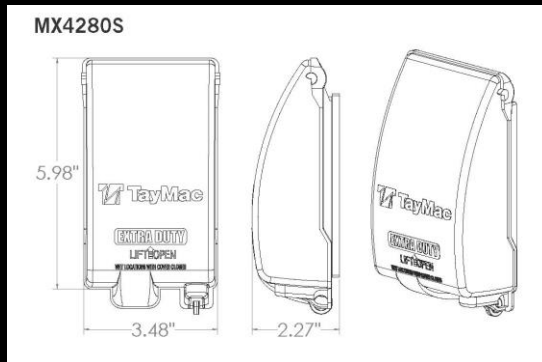

Fort Point Standards with receptacle added on
Congress Street

Congress Street Plan (approved 1/23/2023)

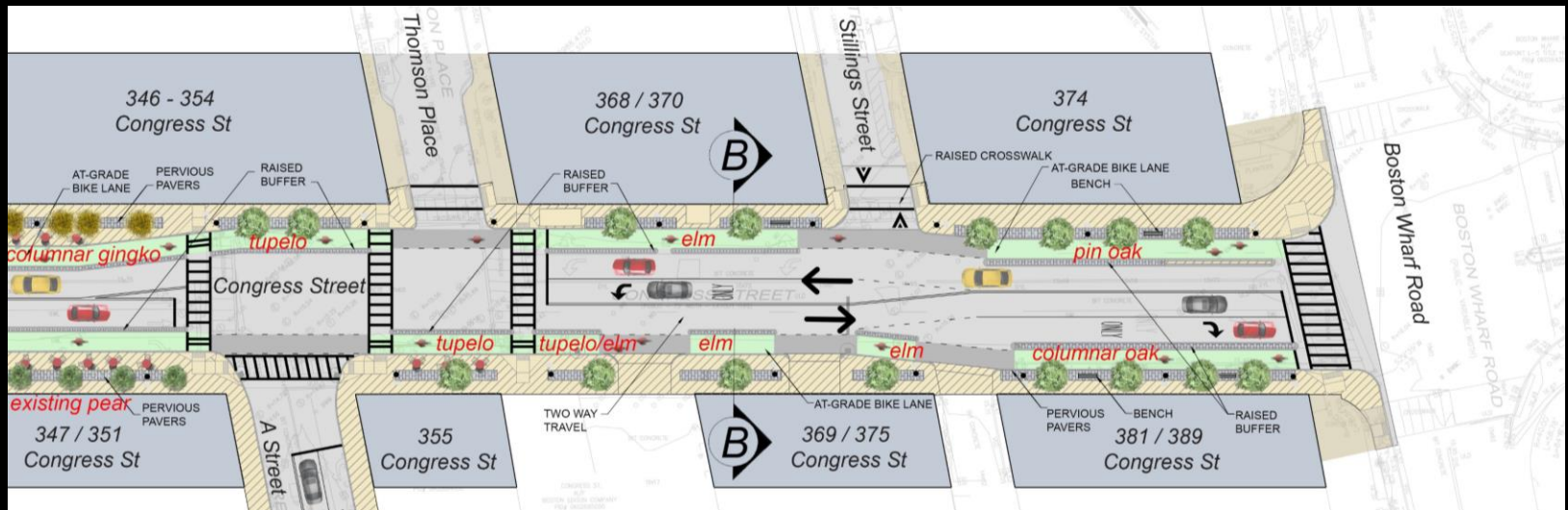
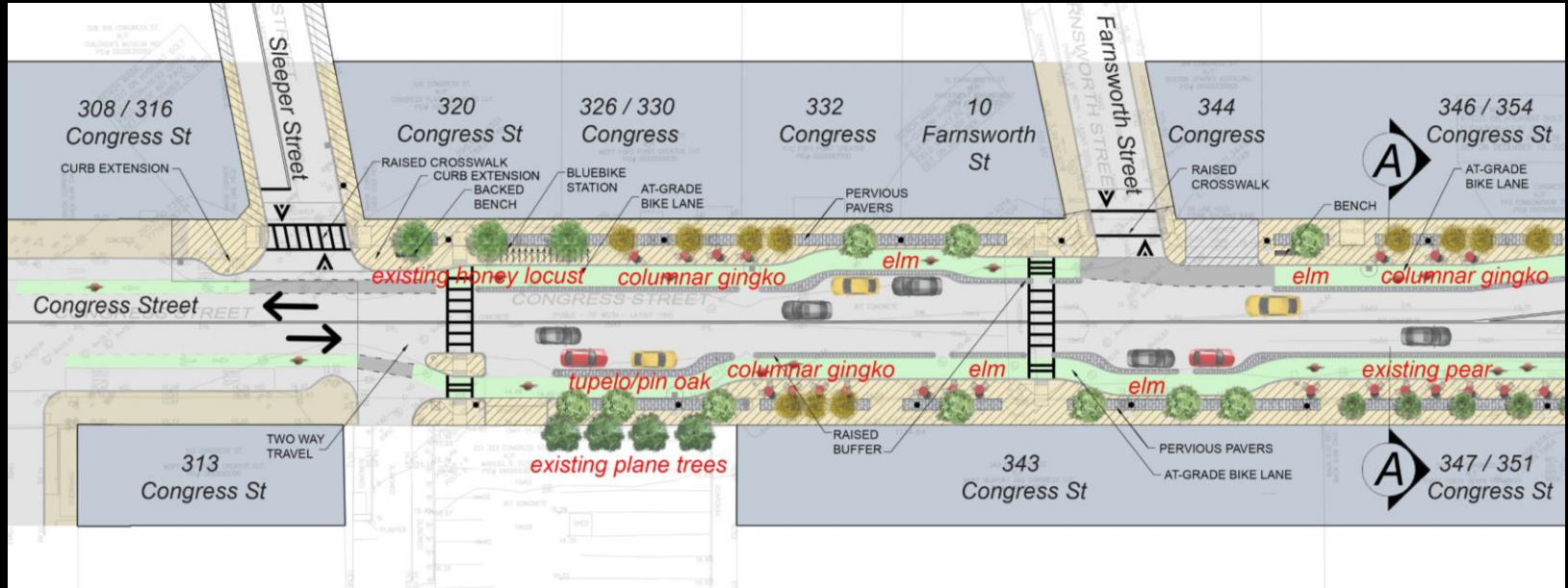

Sleeper and A Streets – Plan (approved 1/23/2023)

