

441 SHAWMUT AVENUE, BOSTON MA 02118

- 1) REMOVE AND REPLACE TWO 3RD FLOOR NON-HISTORIC, FLAT SASH WINDOWS.
PELLA ARCHITECT SERIES RESERVE, WOOD EXTERIOR WINDOWS.
FULL FRAME REPLACEMENT.
DOUBLE HUNG, 2-OVER-2 REPLACEMENTS.
EXISTING FLAT SASH WINDOWS REPLACED WITH NEW FLAT SASH WINDOWS IN CURVED BOW FRONT.
EXTERIOR PAINTED TO MATCH EXISTING.

PLEASE FIND ATTACHED THE FOLLOWING:

- A. DETAILED SPECIFICATIONS FOR THE TWO PROPOSED 3RD FLOOR REPLACEMENTS (PELLA® RESERVE, TRADITIONAL, DOUBLE HUNG, 36.5 X 65)
- B. WINDOW CONSTRUCTION SPECIFICATIONS FOR THE PELLA RESERVE WINDOW THAT WILL BE INSTALLED IN EACH INSTANCE; AND
- C. A FACADE PICTURE OF 441 SHAWMUT. FOR THIS CURRENT PENDING APPLICATION, THE PROPOSED 3RD FLOOR WINDOW REPLACEMENTS ARE THE LEFT TWO WINDOWS IN AREA B.

Customer: Waldron Contracting Services

Project Name: Waldron- 441 Shawmut Ave.

Order Number: 185

Quote Number: 17113858

CUSTOM WDW - Interior/Exterior Custom Paint Window Per Unit

Qty 1

Line #	Location:	Attributes	Qty
--------	-----------	------------	-----

20 UNIT 3

Pella® Reserve, Traditional, Double Hung, 36.5 X 65

Qty

2

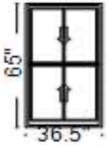

PK #
2140

Viewed From Exterior

1: Traditional, Non-Standard Size Non-Standard Size Double Hung, Equal
Frame Size: 36 1/2 X 65
General Information: Standard, Luxury, Wood, Pine, 4 3/8", 4 3/16"
Exterior Color / Finish: Primed, Primed Wood
Interior Color / Finish: Primed Interior
Sash / Panel: Putty Glaze, Ogee, Standard, No Sash Lugs
Glass: Insulated Dual Low-E Advanced Low-E Insulating Glass Argon Non High Altitude
Hardware Options: Spoon-Style Lock, White, No Window Opening Control Device, No Limited Opening Hardware, No Sash Lift, No Integrated Sensor
Screen: Half Screen, Standard EnduraClad, Black, Standard, InView™
Performance Information: U-Factor 0.29, SHGC 0.25, VLT 0.47, CPD PEL-N-234-01143-00001, Performance Class CW, PG 45, Calculated Positive DP Rating 45, Calculated Negative DP Rating 45, Year Rated 08|11, Clear Opening Width 33.125, Clear Opening Height 28.062, Clear Opening Area 6.455235, Egress Meets Typical 5.7 sqft (E) (United States Only)
Grille: ILT, No Custom Grille, 7/8", Traditional (2W1H / 2W1H), Putty Glaze, Ogee
Wrapping Information: No Exterior Trim, 4 3/16", 4 3/8", Factory Applied, Pella Recommended Clearance, Perimeter Length = 203".

Rough Opening: 37 - 1/4" X 65 - 3/4"

Customer Notes: PAINTED BLACK WOOD EXTERIOR

CUSTOM WDW - Interior/Exterior Custom Paint Window Per Unit

Qty 1



UNIT SECTIONS

Wood Exterior

Vent - Putty Glaze Exterior Profile

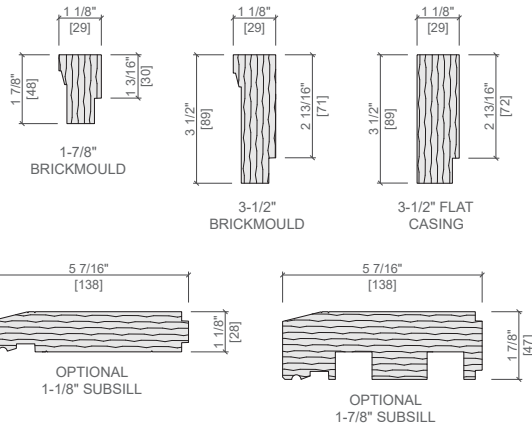
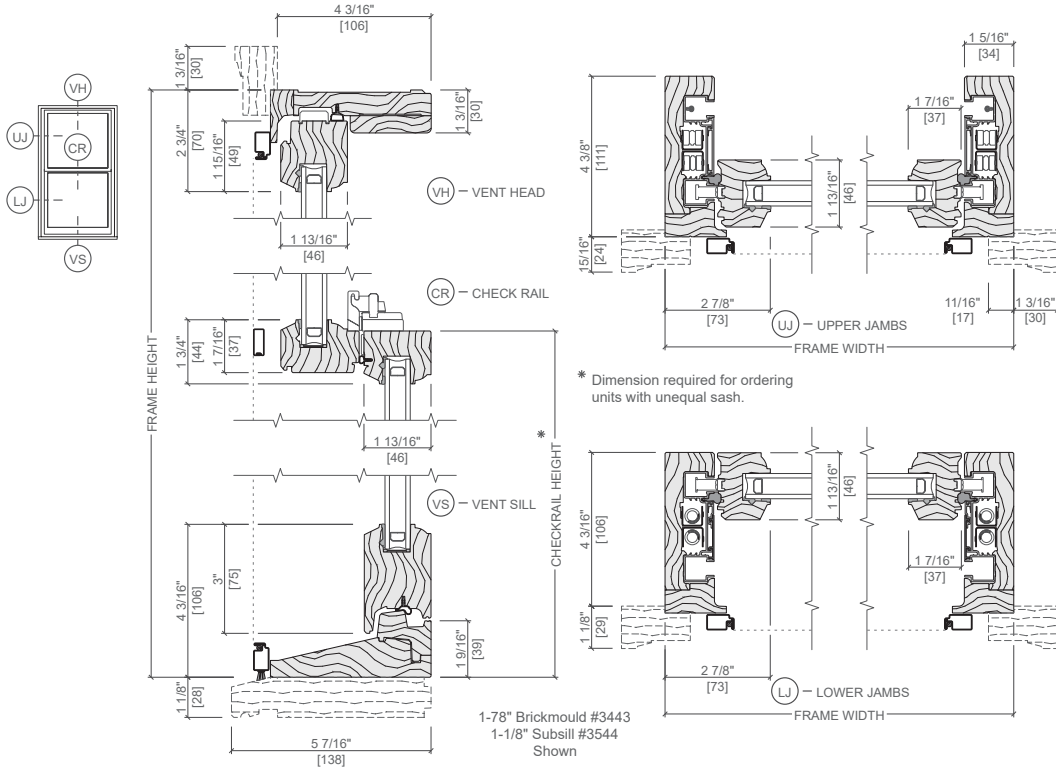

Scale 3" = 1' 0"
All dimensions are approximate.

