

42 NEWBURY STREET
BOSTON, MA 02116



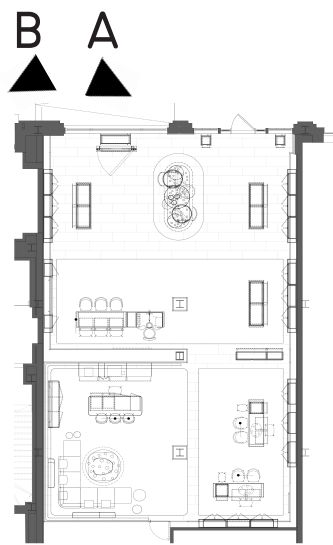
EXISTING CONDITIONS PHOTOS



A

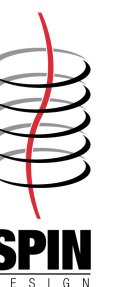


B

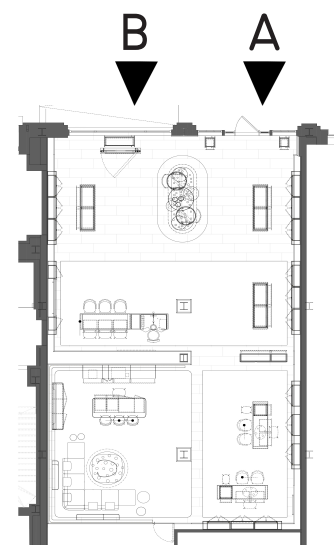


KEY PLAN

42 NEWBURY STREET BOSTON, MA 02116 | FEBRUARY 27, 2024

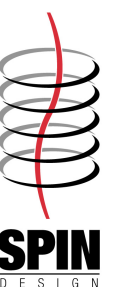


EXISTING CONDITIONS PHOTOS



KEY PLAN

42 NEWBURY STREET BOSTON, MA 02116 | FEBRUARY 27, 2024



EXISTING EXTERIOR ELEVATION



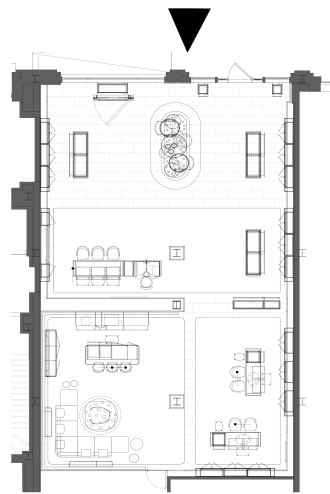
KEY PLAN

42 NEWBURY STREET BOSTON, MA 02116 | FEBRUARY 27, 2024



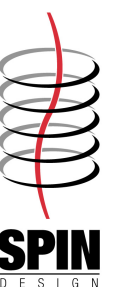
EXISTING RENDERED ELEVATION

NEW RAMP APPROVED
UNDER SEPARATE REVIEW



KEY PLAN

42 NEWBURY STREET BOSTON, MA 02116 | FEBRUARY 27, 2024



PROPOSED EXTERIOR ELEVATION



KEYNOTES

- | | | | |
|-----------------------------------|--|--|----------------------------------|
| 1. NEW OMEGA SIGNAGE (SEE PAGE 8) | 2. NEW MILKY WHITE VINYL | 3. NEW ALUMINUM STOREFRONT FRAMES - BRASS FINISH | 4. EXISTING LIMESTONE |
| 5. EXISTING GRANITE | 6. NEW CLEAR LOW-E GLASS | 7. EXISTING EXTERIOR MARBLE BASE | 8. NEW OMEGA HANDLE (SEE PAGE 9) |
| 9. NEW INTERIOR MILLWORK (BEYOND) | 10. NEW SURFACE MOUNTED OMEGA PLAQUE (SEE PAGE 10) | 11. EXISTING STOREFRONT HEADER | |

42 NEWBURY STREET BOSTON, MA 02116 | FEBRUARY 27, 2024



PROPOSED RENDERED EXTERIOR ELEVATION



MATERIALS & FINISHES

■ 2415 RED ACRYLIC
 ■ MILKY WHITE VINYL
 ■ BRUSHED BRASS FINISH
 ■ EXISTING GREEN MARBLE
 ■ EXISTING STOREFRONT
 ■ EXISTING GRANITE
 ■ EXISTING LIGHT GRAY LIMESTONE

KEYNOTES

- | | | | |
|--|--|--|--|
| 1. ■ NEW OMEGA SIGNAGE (SEE PAGE 8) | 2. ■ NEW MILKY WHITE VINYL | 3. ■ NEW ALUMINUM STOREFRONT FRAMES - BRASS FINISH | 4. ■ EXISTING LIMESTONE |
| 5. ■ EXISTING GRANITE | 6. NEW CLEAR LOW-E GLASS | 7. ■ EXISTING EXTERIOR MARBLE BASE | 8. ■ NEW OMEGA HANDLE (SEE PAGE 9) |
| 9. NEW INTERIOR MILLWORK (BEYOND) | 10. ■ NEW SURFACE MOUNTED OMEGA PLAQUE (SEE PAGE 10) | 11. ■ EXISTING STOREFRONT HEADER | |

42 NEWBURY STREET BOSTON, MA 02116 | FEBRUARY 27, 2024



PROPOSED EXTERIOR FACADE SIGNAGE

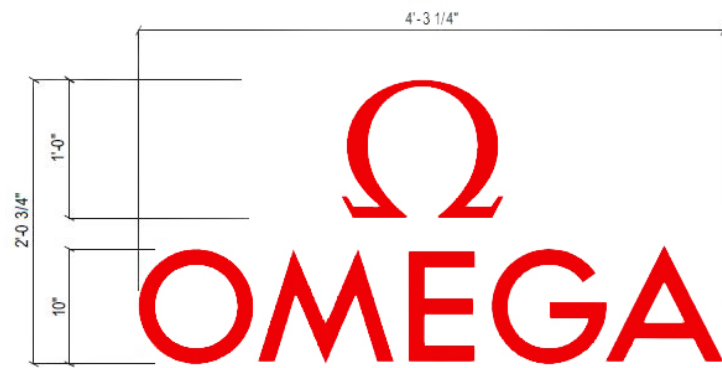
MATERIALS & FINSHES



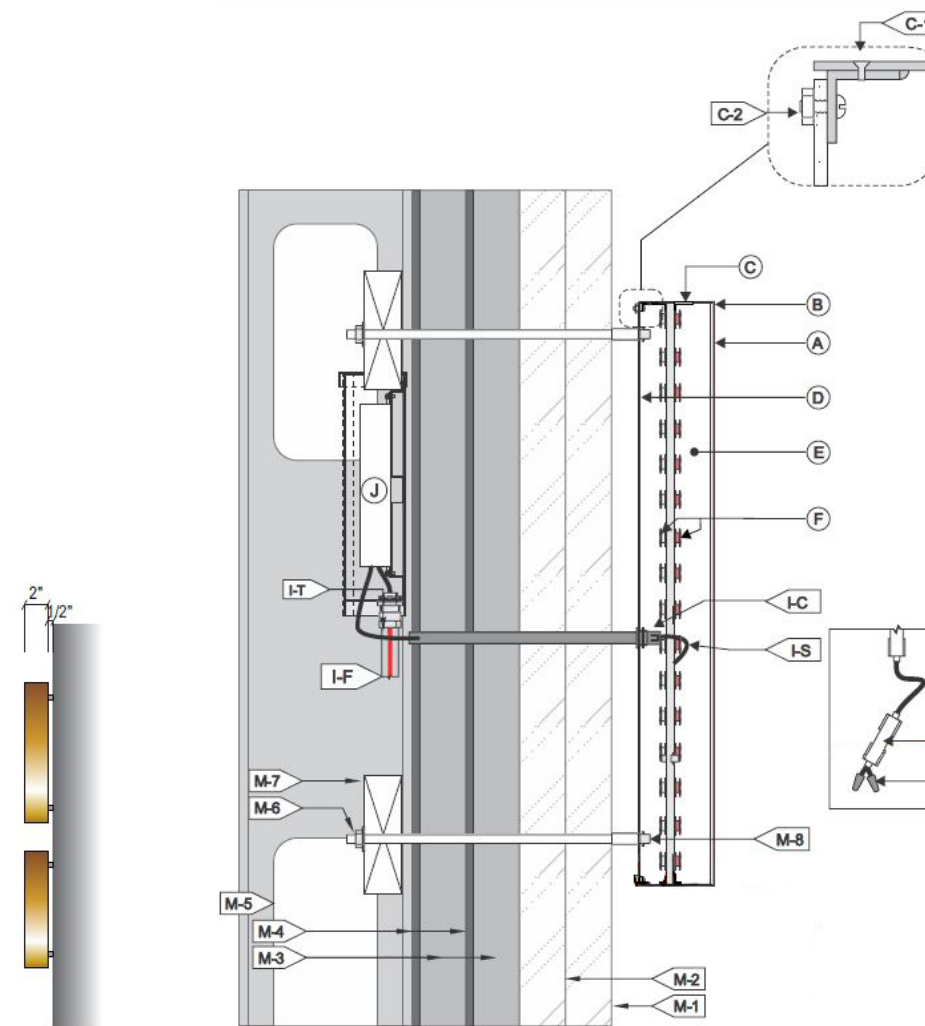
2415 RED
ACRYLIC



GOLD AKZO
319A6



SIGNAGE A



(A) FACE	
MATERIAL:	3/16" ACME PLASTICS 2415 RED
(B) FACE EDGE	
	1/8" ROUTED EDGE FOR PUSH IN FACE
(C) RETURNS	
DEPTH:	2"
MATERIAL:	STAINLESS STEEL
COLOR/ FINISH	GOLD AKZO 319A6
C-1:	FLUSH MOUNT SCREW
C-2:	10/24 BOLT & NUT
(D) BACKS	
MATERIAL:	3/16" #2447 WHITE
(E) INSIDE OF CAN	
COLOR:	PRE-COAT WHITE
(F) ILLUMINATION	
TYPE:	LEDS
COLOR:	4000K - WHITE (REAR FACING) RED LED (FRONT FACING)
F-1	ALL WIRES TO BE TERMINATED W/ A MECHANICAL UL LISTED FASTENER

(I) WIRING	
I-C:	7/8" DIA. HOLE @ LEXAN W/ PAIGE WALL BUSTER CONNECTOR & CONDUIT, WRAP EXPOSED CONDUIT W/ VINYL FINISHED TO MATCH FASCIA
I-F:	TO 120V FEED
I-S:	U.L. APPROVED CLASS II LOW VOLTAGE WIRING
I-D:	DISCONNECT SWITCH w/ HOUSING ON P/S BOX
I-T:	LIQUID TIGHT
I-J:	JUNCTION BOX
(J) POWER SUPPLY	
TYPE:	LOW VOLTAGE U.L. APPROVED LED POWER SUPPLY HOUSE IN BACKER PANEL
VOLTAGE:	120V
(M) MOUNTING SEE MOUNTING NOTE.	
M-1:	EXISTING 3/4" STONE
M-2:	EXISTING 3/4" STONE
M-3:	EXISTING 3/4" PLYWOOD
M-4:	EXISTING SECURITY MESH
M-5:	METAL STUDS
M-6:	1/2" L - CRUSH-PROOF PVC SPACERS
COLOR:	MATCH FASCIA
M-7:	MIN. 3/8" THRU-BOLTS w
M-8:	BLOCKING

PROPOSED EXTERIOR FACADE OMEGA DOOR HANDLES

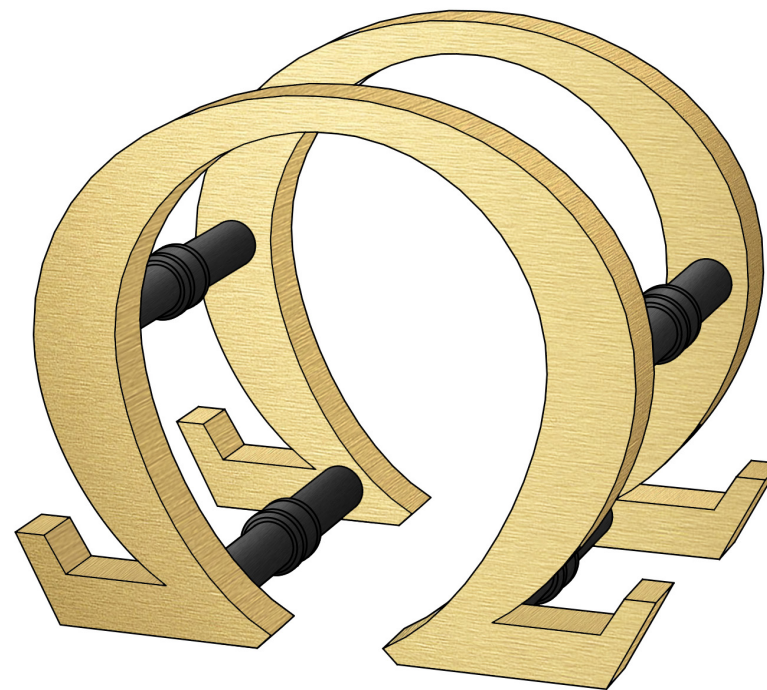
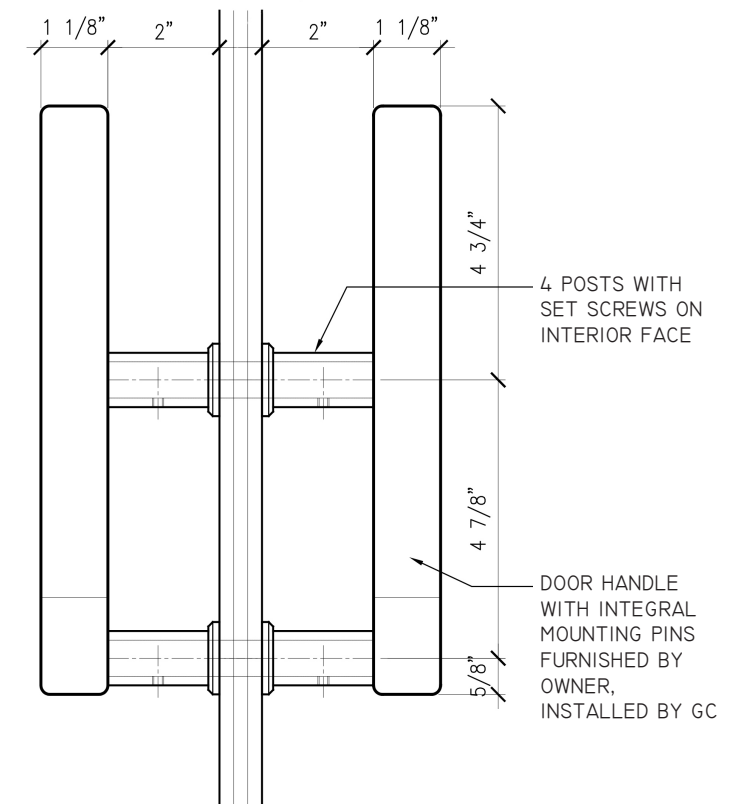
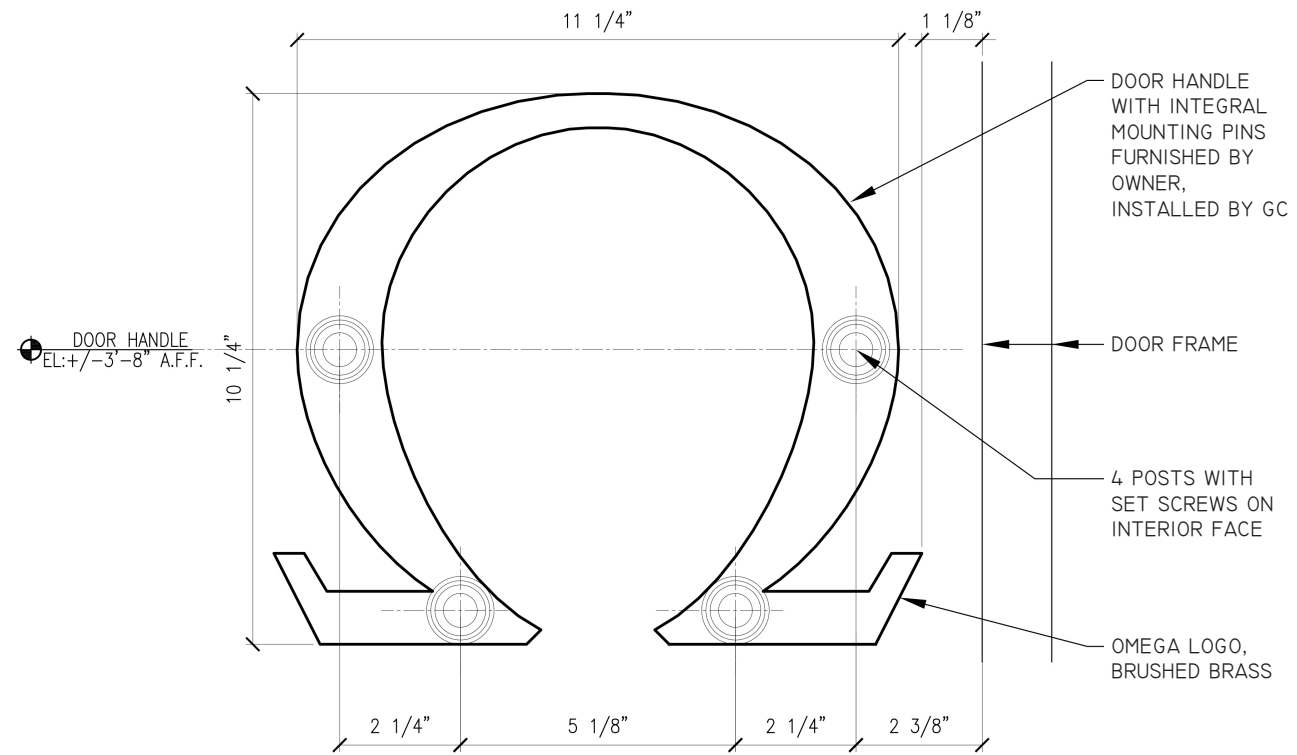
MATERIALS & FINSHES



BRUSHED BRASS
FINISH

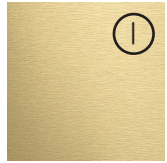


PHOTO FOR REFERENCE - OMEGA US LOCATION

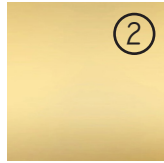


PROPOSED EXTERIOR FACADE OMEGA PLAQUE

MATERIALS & FINISHES



BRUSHED BRASS
FINISH



POLISHED BRASS
FINISH



PARTIAL ELEVATION



PHOTO FOR REFERENCE - OMEGA US LOCATION

